

CATALOG &
TECHNICAL
GUIDE 2018



TOOLING SYSTEMS

SECO 



SOLUTIONS & SUPPORT

By choosing Seco, you get more than just a comprehensive portfolio of advanced metal-cutting solutions and expert services. You get a partnership based on trust, respect and communication and a team that is always ready to help you gain the competitive advantage.

Globally headquartered in Fagersta, Sweden and present in more than 50 countries, Seco develops cutting tools, processes and services for high productivity and profitability. Our team of over 4,000 dedicated employees maintains partnerships around the world to identify and overcome the challenges faced by today's manufacturers.

Our broad selection of milling, turning, holmaking and toolholding solutions include over 30,000 standard products, custom items for special applications and a team of metal-cutting experts who help customers identify and implement cost-effective solutions.

Alphanumeric index	2-5	
Product overview		Guide
Tool holders	6-9	
Operating and setting accessories	10	
Shrinkfit devices	11	
Guide, tool holders		HSK -A/ T/ E
Quality & Balancing	12	
Code key	13	
Machine side norms & workpiece side norms	14-24	
Taper-Face machine side descriptions	25	
Sealing screws and sealing dowels on ADB type holders SA	26-27	
Workpiece sides descriptions	28-71	
Rotating Tool holders		DIN/ DIN TF
HSK-A	72-109	
HSK-T	110-111	
HSK-E	112-117	
DIN 69871	118-151	
DIN Taper-Face	152-155	
BT JIS	156-195	
BT Taper-Face	196-213	
DIN 2080	214-217	
Cylindrical shanks	218-223	
Weldon and Whistle Notch shanks	224-225	
Morse Taper shanks	226	
Combimaster	227-229	
Graflex®	230-246	
Seco-Capto™	247-278	
Turning and boring tool holders, Steadyline®		BT /BT TF
HSK-T/A	279-280	
Seco-Capto™	281-283	
Cylindrical shanks	284-285	
BA-to-GL adapters	286	
Guide, Operating and setting accessories	287-293	Others
Operating and setting accessories		Combimaster
HSK coolant tubes, tube spanners and sealing plugs	294	
MQL1 and MQL2 coolant tubes and stop screws	295-299	
Pull studs	300-306	
Reduction sleeves and control gauges for hydraulic chucks	307-308	
ER High precision collets	309-313	
ER Conventional collets	314-315	
ER Tapping collets with square drive	316-319	
ER Sealing rings	320-321	
ER to Combimaster arbors	322	
OZ collets	323	
Assembly supports Tool Boy	324	
Roller spanners	325	
Guide, Shrinkfit devices	326-333	Graflex®
Shrinkfit devices		Combimaster
Easyshrink® 15 and Easyshrink® 20 devices	334-336	
Accessories and Spare parts	337-339	
SMG	340-351	Graflex®
Declaration of conformity	352-354	Seco-Capto™

Guide

HSK -A/ T/ E

DIN/ DIN TF

BT /BT TF

Others

Combimaster

Graflex®

Seco-Capto™

Steadyline® turning

Accessories

Shrinkfit devices

0

01B5875	320-321
02E93	294
03BR	325
03DYD	325
03E93	294
03ER	325
05F5832	307

1

19MQL	296, 299
-------	----------

2

20E93	294-295, 297-298
-------	------------------

3

393.14	316-319
--------	---------

5

5450	222
5672	309-313
5880	314-315
5883B	323

B

BA.-GL	286
--------	-----

BC

5821	226
------	-----

BD

5801	221
5820	218
5821	218
5822	218
5867	223

BE

5820	322
------	-----

BM

5675	243
6100	246

BS

5603	229
5820	227-228

BW

5821	224
5867	225

C

C.-390.00	216-217
C.-390.410	108-109
C.-390.411	110-111
C.-390.55	192-193
C.-390.605	194-195
C.-390B.140	150-151
C.-390B.55	192-193
C.-390B.58	192-193
C.-391.01	248-249, 252-253
C.-391.02	250-251, 254-255
C.-391.0401	278
C.-391.0552	258
C.-391.0584	262-263
C.-391.20	260-261

C.-391.27	264-265
C.-391.5524	257
C.-391.5525	257
C.-391.5555	256
C.-391.5556	256
C.-391.5600	268
C.-391.5600P	269
C.-391.5603	266-267
C.-391.5657	259
C.-391.5672	273
C.-391.5675	274
C.-391.5820	277
C.-391.5831	271
C.-391.5834	270
C.-391.5835	272
C.-391.5867	275
C.-391.K820	276
C.-391.K821	276
C.-D.-BA	283
C.-D.-GL	281-282
CA5832	308

D

D.-BA	285
D.-GL	284

E

E3114

5191	212-213
------	---------

E3116

5191	212-213
------	---------

E3169

5191	154-155
------	---------

E3171

5191	154-155
------	---------

E3214

5525	198
5555	196
5600	202
5600P	203
5672	205
5675	207
5820	209
5835	206
584	200
K820	208

E3216

5525	198
5555	196
5600	202
5600P	203
5672	205
5675	207
5820	209
5835	206
584	200
K820	208

E3269

K820	153
------	-----

E3271

K820	153
------	-----

E3414		K820	143
5023	183	K821	143
5085	180	E3471	
5525	157	5023	141
5555	156	5085	138
5556	156	5525	120
5600	169	5555	118
5600P	171	5556	118
5603	166-167	5600	130
5672	173	5600P	131
5675	178	5603	128
5801	172	5672	133
5820	186	5675	136
5821	186	5820	144
5831	175	5821	144
5834	174	5834	134
5835	176	5835	135
584	162	584	125
5842	164	5842	126
5873	179	5873	137
K820	185	K820	143
K821	185	K821	143
E3416		E3476	
5023	183	5801	132
5085	180	5820	145
5524	158	5821	145
5525	158	E3478	
5555	156	5820	146
5556	156	5842	126
5600	170	E4002	
5600P	171	5191	212-213
5603	168	5525	197
5672	173	5603	201
5675	178	5672	204
5820	187	5820	209
5821	187	584	199
5834	174	E4040	
5835	176	552	159
584	163	5603	165
5842	164	5672	173
5873	179	5675	177
K820	185	5867	181
K821	185	E4041	
E3469		552	159
5023	141	5657	161
5085	138	5675	178
5524	119	586	184
5525	119	5867	181
5555	118	E4469	
5556	118	552	121
5600	129	5657	123
5600P	131	5675	136
5603	127	586	142
5672	133	5867	139
5675	136	E4471	
5820	144	543	140
5821	144	552	121
5834	134	5657	123
5835	135	569	122
584	124	586	142
5842	126	5867	139
5873	137		

E5766			
543	182	
552	159	
5657	161	
569	160	
5867	181	
E9302			
5023	103	
5603	80	
5672	96	
5675	100	
5801	95	
E9304			
5023	103	
5085	101	
5403	80-83	
5403M	84-85	
5403M1	86-87	
5403M2	88-91	
552	75	
5524	73	
5525	73	
5555	72	
5556	72	
5600	92	
5600P	94	
5657	77	
5672	96	
5675	100	
5801	95	
5820	106	
5821	106	
5831	98	
5834	97	
5835	99	
584	78	
586	104	
5867	102	
K820	105	
K821	105	
E9306			
5023	103	
5085	101	
5403	82-83	
5403M	85	
5403M1	87	
5403M2	90-91	
5524	74	
5525	74	
5555	72	
5556	72	
5600	93	
5600P	94	
5657	77	
5672	96	
5675	100	
569	76	
5801	95	
5820	106	
5821	106	
5831	98	
5834	97	
5835	99	
584	78	
586	104	
5867	102	
K820	105	
K821	105	
E9340			
5672	116	
E9341			
5603	112	
5672	116	
5675	117	
E9342			
5603	113	
5672	116	
5675	117	
5801	115	
E9343			
5603	114	
5672	116	
5675	117	
5801	115	
E9374			
GL	279	
E9376			
BA	280	
GL	279	
EM			
0040	214	
0050	214	
3214	210	
3216	210	
3414	189	
3416	190	
3469	148	
3471	149	
4002	210	
4040	188	
4464	147	
9303	107	
9304	107	
9306	107	
EM3414	189	
EM3416	190	
EM3469	148	
EM3471	149	
EM9304	107	
M			
M211	324	
M401	219-220	
M402	230-231	
M403	232-236	
M5085	245	
M5524	237	
M5525	237-238	
M5656	240	
M569	239	
M5834	242	
M584	241	
M5873	244	

P

PS-B.....	303-305
PS-I.....	300-302
PS-V.....	306

Z

ZFAD05.....	338
ZFAG01.....	337
ZFAR02.....	338
ZFAR03C.....	338
ZFAR07.....	338
ZFAR08.....	338
ZFAR10D.....	339
ZFAT.....	337
ZFCE.....	337
ZFCM08IN.....	337
ZFM07IN.....	334-335
ZFM07RE1.....	336
ZFM08IN.....	334
ZFS07IN.....	337

Tool holders

Machine side vs Workpiece side

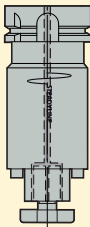
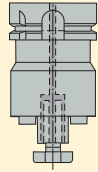
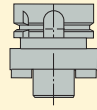
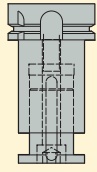
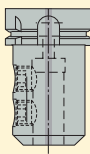
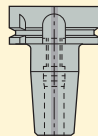
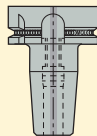
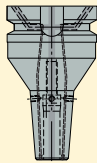
	Steadyline® shell mill holders	Shell mill holders	Milling cutter holders, flange mounting	Disc mill holders
				
Guide pages:	28-30, 25	31, 25, 64	31, 64	32, 64
Product pages:				
HSK-A	72	73-75	76	77
HSK-T	-	-	-	-
HSK-E	-	-	-	-
DIN 69871/ DIN TF	118 / -	119-121 / -	122 / -	123 / -
JIS (BT)/ BT TF	156 / 196	157-159 / 197-198	160 / -	161 / -
DIN 2080	-	-	-	-
Combimaster	-	-	-	-
Graflex®	-	237-238	239	240
Seco-Capto™	256	257-258	-	259
Cyl/ Weldon/ MT	- / - / -	- / - / -	- / - / -	- / - / -
	Side lock holders, Weldon	Shrinkfit holders, DIN type	Shrinkfit holders, MQL type	Shrinkfit holders, reinforced
				
Guide pages:	32, 25, 64	33-34, 25	33, 35-37	33, 38, 25
Product pages:				
HSK-A	78-79	80-83	84-91	92-93
HSK-T	-	-	-	-
HSK-E	-	112-114	-	-
DIN 69871/ DIN TF	124-126 / -	127-128 / -	- / -	129-130 / -
JIS (BT)/ BT TF	162-164 / 199-200	165-168 / 201	- / -	169-170 / 202
DIN 2080	-	-	-	-
Combimaster	-	229	-	-
Graflex®	241	-	-	-
Seco-Capto™	260-265	266-269	-	-
Cyl/ Weldon/ MT	- / - / -	221 / - / -	- / - / -	- / - / -

Tool holders

Machine side vs Workpiece side

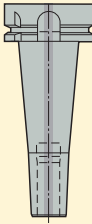
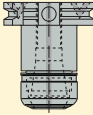
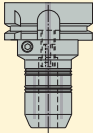
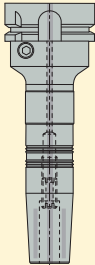
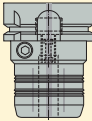
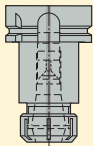
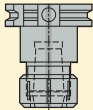
	Shrinkfit holders, reinforced and with tool pull-out protection	Shrinkfit holders, Mould and Die type	High precision collet chucks	Hydraulic chucks
				
Guide pages:	33, 39, 25	33, 39	40-41, 25	42-44, 64
Product pages:				
HSK-A	94	95	96	97
HSK-T	-	-	-	-
HSK-E	-	115	116	-
DIN 69871/ DIN TF	131 / -	132 / -	133 / -	134 / -
JIS (BT)/ BT TF	171 / 203	172 / -	173 / 204-205	174 / -
DIN 2080	-	-	-	-
Combimaster	-	-	-	-
Graflex®	-	-	-	242
Seco-Capto™	-	-	273	270
Cyl/ Weldon/ MT	- / - / -	- / - / -	- / - / -	- / - / -
	Hydraulic chucks, slim	Hydraulic chucks, strong	ER collet chucks	OZ collet chucks
				
Guide pages:	42-43, 45-46	42-43, 47, 25	48, 25, 64	50, 64
Product pages:				
HSK-A	98	99	100	-
HSK-T	-	-	-	-
HSK-E	-	-	117	-
DIN 69871/ DIN TF	- / -	135 / -	136 / -	137 / -
JIS (BT)/ BT TF	175 / -	176 / 206	177-178 / 207	179 / -
DIN 2080	-	-	-	-
Combimaster	-	-	-	-
Graflex®	-	-	243	244
Seco-Capto™	271	272	274	-
Cyl/ Weldon/ MT	- / - / -	- / - / -	222 / - / -	- / - / -

Tool holders

Machine side vs Workpiece side

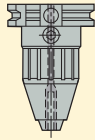
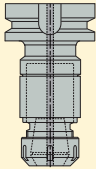
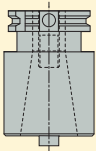
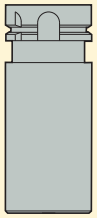
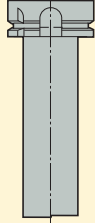
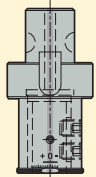
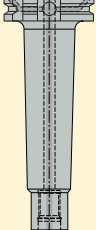
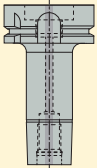
	Adjustable drill chucks	Tapping chucks for synchronized tapping, with micro-compensation	Taper adapters SA	Greenstock blanks
				
Guide pages:	50, 64	51	-	52
Product pages:				
HSK-A	101	102	-	103
HSK-T	-	-	-	-
HSK-E	-	-	-	-
DIN 69871/ DIN TF	138 / -	139 / -	140 / -	141 / -
JIS (BT)/ BT TF	180 / -	181 / -	182 / -	183 / -
DIN 2080	-	-	-	-
Combimaster	-	-	-	-
Graflex®	245	-	-	-
Seco-Capto™	-	275	-	-
Cyl/ Weldon/ MT	- / - / -	223 / 225 / -	- / - / -	- / - / -
	Control bars	Adjustable drill holders	Steadyline® vibration damping Combimaster arbors	Combimaster
				
Guide pages:	53	52, 64	25, 55-56	25-54
Product pages:				
HSK-A	104	-	105	106
HSK-T	-	-	-	-
HSK-E	-	-	-	-
DIN 69871/ DIN TF	142 / -	- / -	143 / 153	144-146 / -
JIS (BT)/ BT TF	184 / -	- / -	185 / 208	186-187 / 209
DIN 2080	-	-	-	-
Combimaster	-	-	-	227-229
Graflex®	-	246	-	-
Seco-Capto™	-	-	276	277
Cyl/ Weldon/ MT	- / - / -	- / - / -	- / - / -	218 / 224 / 226

Tool holders

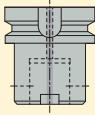
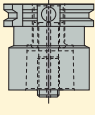
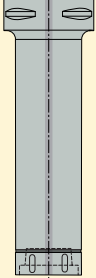

Machine side vs Workpiece side

	Graflex®	Seco-Capto™	Steadyline® GL and BA
			
Guide pages:	25, 62-64	25, 65-67	68-71
Product pages:			
HSK-A	107	108-109	279-280, 286
HSK-T	–	110-111	279-280, 286
HSK-E	–	–	–
DIN 69871/ DIN TF	147-149 / –	150-151 / 154-155	– / –
JIS (BT)/ BT TF	188-190 / 210	192-195 / 212-213	– / –
DIN 2080	214	216-217	–
Combimaster	–	–	–
Graflex®	230-236	–	–
Seco-Capto™	278	248-255	281-283, 286
Cyl/ Weldon/ MT	219-220 / – / –	– / – / –	284-286

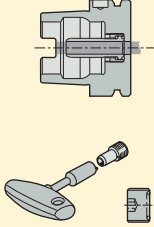
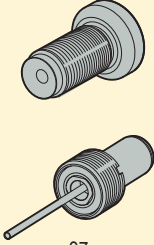
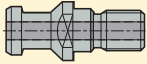
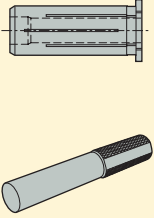
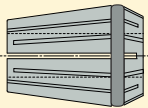
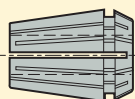
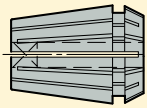
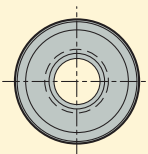
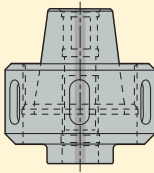
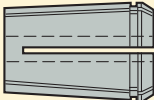
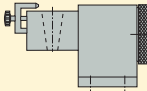
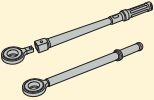
Operating & setting accessories

<p>Guide pages:</p> <p>Product pages:</p>	<p>HSK coolant tubes and sealing plugs (incl. tube fitting keys)</p>  <p>287</p> <p>294</p>	<p>MQL1 and MQL2 coolant tubes and stop screws</p>  <p>37</p> <p>295-299</p>	<p>Pull studs</p>  <p>287</p> <p>300-306</p>	<p>Reduction sleeves, control gauges for hydraulic chucks</p>  <p>288</p> <p>307-308</p>
<p>Guide pages:</p> <p>Product pages:</p>	<p>ER HP collets (not sealed, sealed, sealed with coolant supply channels)</p>  <p>289</p> <p>309-313</p>	<p>ER collets</p>  <p>290</p> <p>314-315</p>	<p>ER tapping collets with square drive</p>  <p>292</p> <p>316-319</p>	<p>ER sealing rings</p>  <p>291</p> <p>320-321</p>
<p>Guide pages:</p> <p>Product pages:</p>	<p>ER to Combimaster arbors</p>  <p>57</p> <p>322</p>	<p>OZ collets</p>  <p>291</p> <p>323</p>	<p>Assembly supports, Tool Boy</p>  <p>292</p> <p>324</p>	<p>Torque roller spanners (socket / torque key) and classic roller spanners</p>  <p>293</p> <p>325</p>

Shrinkfit devices

	<p>Easyshrink® 15 device</p> 	<p>Packs Easyshrink® 20</p> 	<p>Refrigerated water cooling bells unit</p> 
Guide pages:	326-328	326, 329-332	332
Product pages:	334	334-335	336
	<p>Easyshrink® 15 and Easyshrink® 20 accessories and spare parts</p> 	<p>Accessories for refrigerated water cooling bells unit</p> 	
Guide pages:	333	332	
Product pages:	337-338	339	

Quality

The philosophy behind Seco-EPB products is based on total quality and is applied to each and every tool

holder in the EPB range. Controls are carried out at all stages of the manufacturing process in accordance with ISO 9001.

- Material characteristics - 'classic' SA and HSK tool holders = case hardened steels, surface hardness 58 ± 2 HRC - Shrinkfit and hydraulic holders = through hardened steels chosen for their superior performances, hardness 56 ± 2 HRC.
- Taper precision - SA tapers according to ISO 1947, tolerance class AT3 - HSK according to ISO 12164.
- Geometrical tolerances - direct run-out measured on the holder and/or run-out measured on a test gauge are in the catalogue. Run-out controls are made by simulating a spindle fitting.
- Overall finish - deburred, black oxide or special surface treatment and laser marking.
- Traceability - individual product marking relates to the quality information that is available.
- Balancing information is listed in this catalogue for each holder.



Balancing

The balancing quality of each tool holder is shown in its Product page balancing column.

Simplified codes “G2.5”, “G6.3”, “PB” and “-” are used and correspond to:

“G2.5”: Individually balanced at G2,5-25.000 rpm

“G6.3”: Individually balanced at G6,3-20.000 rpm. Can be balanced to G2,5-25.000 on request, please enquire.

“PB”: Pre-balanced by design. Most of the pre-balanced holders can be fine balanced on request, please enquire.

“-”: not balanced

Code key

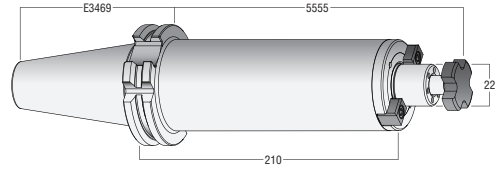
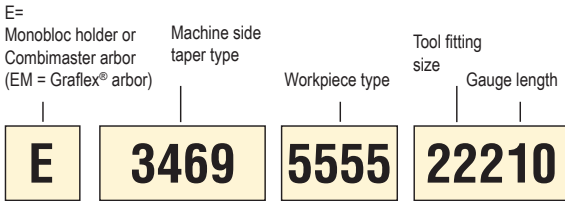

Workpiece side tool holding types

5555/5556	Steadyline® shell mill holders
5525/5524	Shell mill holders with through coolant channels (5524 = small face)
552	Shell mill holders (small face)
569	Milling cutter holders, flange mounting
5656/5657	Disc mill holders
584	Side lock holders, Weldon
5842	Side lock holders, Weldon short
5603/5403	Shrinkfit holders, DIN type
5403M, 5403M1, 5403M2	Shrinkfit holders, MQL type
5600	Shrinkfit holders reinforced
5600 Safe-Lock™	Shrinkfit holders reinforced with tool pull-out protection
5801	Shrinkfit holders, Mould and Die type
5672	High precision collet chucks
5834	Hydraulic chucks
5831	Hydraulic chucks, slim
5835	Hydraulic chucks, strong
5675	ER collet chucks
5450	ER collet chucks, with cylindrical shank
5873	OZ collet chucks
5085	Adjustable drill chucks
5867	Tapping chucks for synchronized tapping, with micro compensation
543	Taper adapters SA
5023	Greenstock blanks
586	Control bars
6100/6101	Adjustable drill holders
K820/K821	Steadyline® vibration damping Combimaster holders
5820/5821/5822	Combimaster arbors
GL/BA	Steadyline® turning
401	Graflex® arbors
C	Seco-Capto™ arbors

Delivery contents

Each item is delivered with all components included, also shown in the Product pages as 'Spare parts' (e.g. Weldon locking screw).

'Operating & setting accessories' (e.g. ER collet) are not included in the delivery content, please order separately.

Holes for RFID carrier

Product pages contain a column 'RFID hole', mentioning if a hole for RFID carrier is available on the tool holders:

RFID hole = 1: the tool holder feature a hole for RFID carrier, according to respective machine side norms. See page(s) 14-24. RFID carriers can be fitted on request, please enquire.

RFID hole = 0: RFID carrier hole not available. Holes for RFID carriers can be machined and RFID carriers fitted on request, please enquire.

HSK-A, norm dimensions

ISO 12164-1-HSK-A

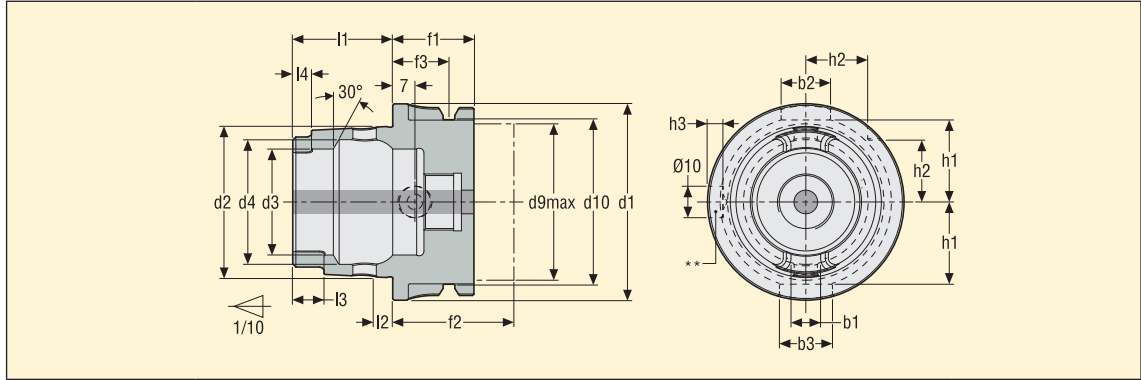

Machine side catalogue designation	Hole for RFID carrier**	Dimensions in mm																		
		d_1	d_2	$d_9\text{max}$	d_3	d_{10}	d_4	f_1	f_2	f_3	l_1	l_2	l_3	l_4	b_1	b_2	b_3	h_1	h_2	$h_3^{+0.2}$
HSK-A32	**	32	24	26	17	26,5	20,5	20	35	16	16	3,2	5,0	3,0	7,05	7	9	13,0	9,5	5,4
HSK-A40	**	40	30	34	21	34,8	25,5	20	35	16	20	4,0	6,0	3,5	8,05	9	11	17,0	12,0	5,2
HSK-A50	**	50	38	42	26	43,0	32,0	26	42	18	25	5,0	7,5	4,5	10,54	12	14	21,0	15,5	5,1
HSK-A63	**	63	48	53	34	55,0	40,0	26	42	18	32	6,3	10,0	6,0	12,54	16	18	26,5	20,0	5,0
HSK-A80	**	80	60	67	42	70,0	50,0	26	42	18	40	8,0	12,0	8,0	16,04	18	20	34,0	25,0	4,9
HSK-A100	**	100	75	88	53	92,0	63,0	29	45	20	50	10,0	15,0	10,0	20,02	20	22	44,0	31,5	4,9
HSK-A125	**	125	95	111	67	117,0	80,0	29	45	20	63	12,5	19,0	12,0	25,02	25	28	55,5	31,5	4,8

Seco's holders HSK-A have a radial hole through the taper for manual clamping, compatible with HSK-C.

Note: These machine side dimensions are applied to all the holders shown in the Product pages.

** In order to know if a hole for RFID carrier exists, see 'RFID hole' column in Product pages: 1= hole for RFID carrier available, if required a carrier can be fitted on request, please enquire.

0= hole for RFID carrier not available, if required hole can be machined and a carrier can be fitted on request, please enquire.

HSK-T, norm dimensions

ISO 12164-3-HSK-T

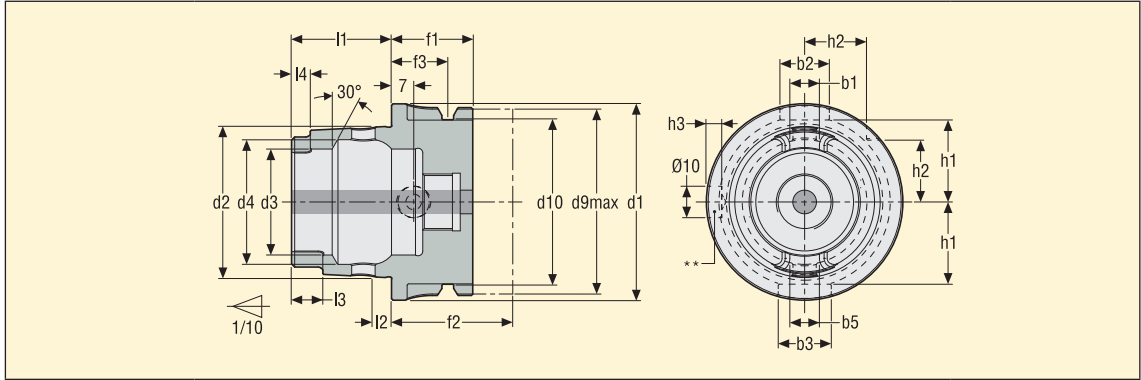

Machine side catalogue designation	Hole for RFID carrier**	Dimensions in mm																			
		d ₁	d ₂	d _{9 max}	d ₃	d ₁₀	d ₄	f ₁	f ₂	f ₃	l ₁	l ₂	l ₃	l ₄	b ₁	b ₂	b ₃	b ₅	h ₁	h ₂	h ₃ ^{+0,2}
HSK-T63	**	63	48	62	34	55	40	26	30	18	32	6,3	10	6	12,54	16	18	12,425	26,5	20,0	5,0
HSK-T100	**	100	75	99	53	92	63	29	34	20	50	10,0	15	10	20,02	20	22	19,910	44,0	31,5	4,9

Note: These machine side dimensions are applied to all the holders shown in the Product pages.

For HSK sealing plugs, coolant tubes and tube spanners, see chapter Operating & setting accessories.

** In order to know if a hole for RFID carrier exists, see 'RFID hole' column in Product pages: 1= hole for RFID carrier available, if required a carrier can be fitted on request, please enquire.

0= hole for RFID carrier not available, if required hole can be machined and a carrier can be fitted on request, please enquire.

Tooling with HSK-T/A machine sides are suitable for static & rotating operations on machines with:

- HSK-T spindles (eg. spindles and turrets on turning and multi-task machines).
- HSK-A spindles (eg. machining centres).

HSK-T/A is conform to the HSK-T ISO standard, and compatible for the HSK-A spindles : eg. diameter BD of Steadyline® GL holders are inside the HSK-flange clearance diameter d_{9 max} allowed by HSK-A ISO standard.

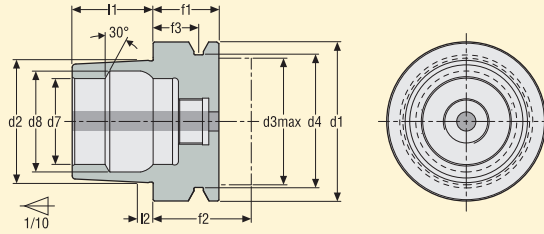

Machine side catalogue designation	Hole for RFID carrier*	Dimensions in mm										
		d ₁	d ₂	d ₃ max	d ₄	d ₇	d ₈	f ₁	f ₂	f ₃	l ₁	l ₂
HSK-E32	No*	32	24	26	26,5	17	21,0	20	35	16	16	3,2
HSK-E40	No*	40	30	34	34,8	21	25,5	20	35	16	20	4,0
HSK-E50	No*	50	38	42	43,0	26	32,0	26	42	18	25	5,0

Note: These machine side dimensions are applied to all the holders shown in the Product pages.

For HSK sealing plugs, coolant tubes and tube spanners, see chapter Operating & setting accessories.

* No hole for RFID carriers. If required, hole can be machined and a RFID carrier can be fitted on request, please enquire.

DIN 69871-A/AD/B/ADB, norm dimensions

DIN 69871-A/AD/B (ISO 7388-1-A/AD/AF) and CAT-A/AD/B (ISO 7388-1-U/UD/UF)

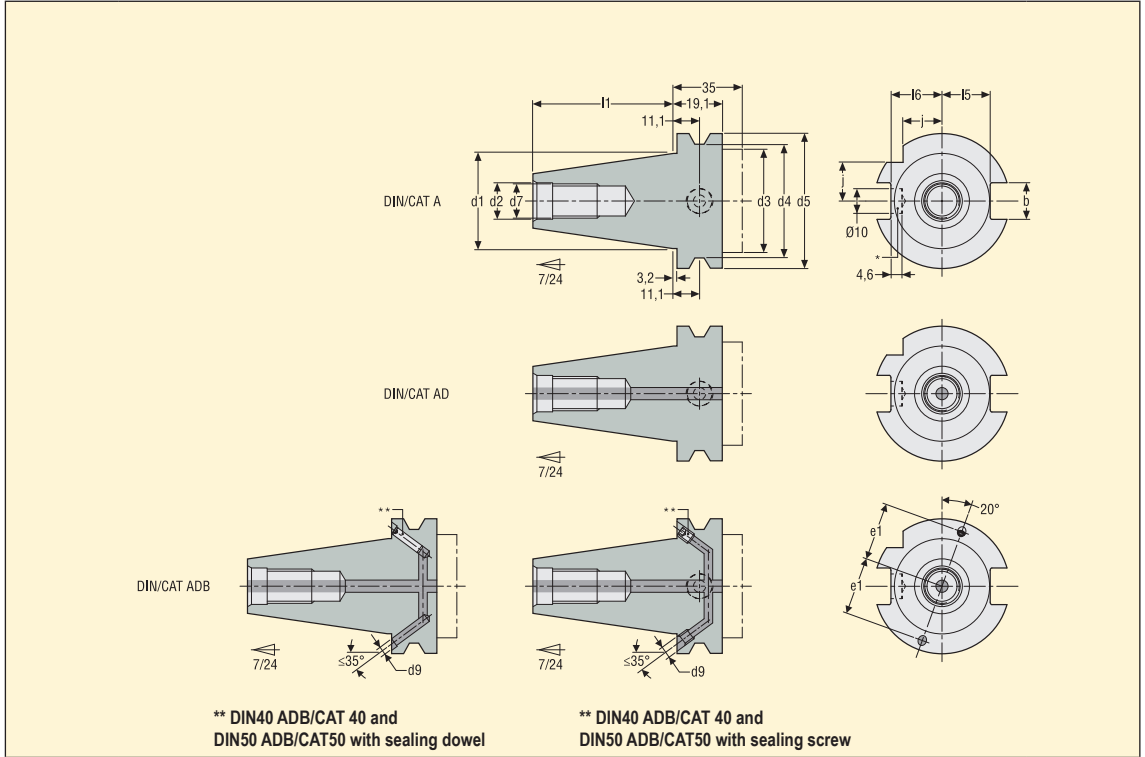

Machine side catalogue designation	Through coolant Form	Plugs**	Hole for RFID carrier*	Dimensions in mm												
				d ₁	d ₃	d ₄	d ₅	l ₁ ^{-0,2/0}	d ₇ ^{6H}	d ₂ ^{H7}	d ₉	e ₁	l ₅	l ₆	b	j
DIN30	A/AD	–	No*	31,75	45 max	44,30	50,00	47,80	M12	13	–	–	16,4	19,0	16,1	15,0
DIN40	A/AD	–	*	44,45	50 max	56,25	63,55	68,40	M16	17	–	–	22,8	25,0	16,1	18,5
DIN40 AD/CAT40	A/AD	–	*	44,45	44,45	56,25	63,55	68,40	M16	17	–	–	22,8	25,0	16,1	18,5
DIN40 ADB	A/AD/B	Screw	*	44,45	50 max	56,25	63,55	68,40	M16	17	4	27	22,8	25,0	16,1	18,5
DIN40 ADB/CAT 40	A/AD/B	Screw	*	44,45	44,45	56,25	63,55	68,40	M16	17	4	27	22,8	25,0	16,1	18,5
DIN45	A/AD	–	*	57,15	63 max	75,00	82,55	82,70	M20	21	–	–	29,1	31,3	19,3	24,0
DIN50	A/AD	–	*	69,85	80 max	91,25	97,50	101,75	M24	25	–	–	35,5	37,7	25,7	30,0
DIN50 AD/CAT50	A/AD	–	*	69,85	69,85	91,25	97,50	101,75	M24	25	–	–	35,5	37,7	25,7	30,0
DIN50 ADB	A/AD/B	Screw	*	69,85	80 max	91,25	97,50	101,75	M24	25	6	42	35,5	37,7	25,7	30,0
DIN50 ADB/CAT50	A/AD/B	Screw	*	69,85	69,85	91,25	97,50	101,75	M24	25	6	42	35,5	37,7	25,7	30,0

Note: These machine side dimensions are applied to all the holders shown in the Product pages.

* In order to know if a hole for RFID carrier exists, see 'RFID hole' column in Product pages: 1= hole for RFID carrier available, if required a carrier can be fitted on request, please enquire.

0= hole for RFID carrier not available, if required hole can be machined and a carrier can be fitted on request, please enquire.

** ADB type holders have two removable 'screws' in the flange, in order to realise all through coolant types A, AD, or B. Plugs (screws) are available as spare parts, see Product pages. For screw removing/re-fitting, see instructions on page(s) 26-27. For pull studs, see page(s) 300-306.

DIN/ CAT (Combined) indicate these holders of the DIN 69871 range feature the fixed diameter d3 of the ANSI B5 50/CAT norm (full ANSICAT conformity restricted by timing notch inclusion and metric pull-stud thread).

Note: Holders conforming to ANSI B5 50/ CAT machine sides (with imperial pull-stud threads) are shown in a separate 'Inch Tooling Systems' catalogue, please enquire.

DIN with Taper-Face* tooling machine sides, dimensions

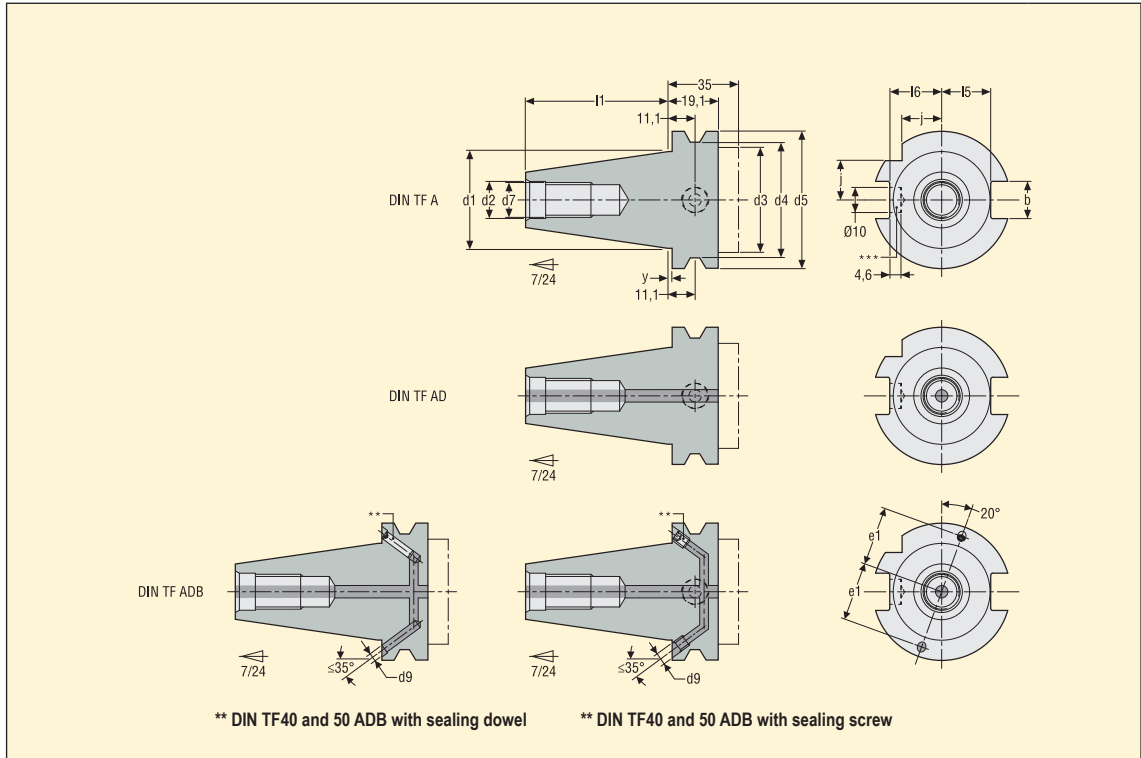

Machine side catalogue designation	Through coolant Form	Plugs**	Hole for RFID carrier***	Dimensions in mm													
				d ₁	d ₂	d ₃ max	d ₄	d ₅	d ₇	d ₉	l ₁ ^{-0,20}	l ₅	l ₆	e ₁	b	j	y
DIN TF40 ADB	A/AD/B	Dowel	No	44,45	17,7	50	56,25	63,55	M16	4	68,40	22,8	25,0	27	16,1	18,5	1,0
DIN TF40 ADB	A/AD/B	Screw	Yes***	44,45	17,7	50	56,25	63,55	M16	4	68,40	22,8	25,0	27	16,1	18,5	1,0
DIN TF50 ADB	A/AD/B	Dowel	No	69,85	25,0	80	91,25	97,50	M24	6	101,75	35,5	37,7	42	25,7	30,0	1,5
DIN TF50 ADB	A/AD/B	Screw	Yes***	69,85	25,0	80	91,25	97,50	M24	6	101,75	35,5	37,7	42	25,7	30,0	1,5

Note: These machine side dimensions are applied to all the holders shown in the Product pages.

* DIN with Taper-Face tooling machine sides are:

– conform to the DIN 69871-A/AD/B (ISO 7388-1-A/AD/AF) norm.

– except that they have a larger flange towards machine side, with tight tolerances: This achieves taper and face contacts on machine spindles with Taper-Face dimensions. Taper-Face tooling is also usable on standard spindles, but in that case a gap remains between spindle and flange faces.

** ADB type holders have two removable 'screws' or 'dowels' in the flange, in order to realise all through coolant types A, AD, or B. Plugs (screws or dowels) are available as spare parts, see Product pages. For screw removing/re-fitting and for dowel replacement, see instructions on page(s) 26-27.

*** In order to know if a hole for RFID carrier exists, see 'RFID hole' column in Product pages: 1= hole for RFID carrier available, if required a carrier can be fitted on request, please enquire.

0= hole for RFID carrier not available, if required hole can be machined and a carrier can be fitted on request, please enquire.

Note : in the catalogue pages, we use as previously the short description 'DIN' for DIN/ ISO, and add 'TF' for these Taper-Face tooling machine sides. The exact machine side types can be recognised by Part No. code's 5 first digits E.... specifying the norm, the Taper-Face feature, the through coolant type, and the data carrier blind hole availability.

BT JIS-A/AD/B/ADB, norm dimensions

JIS B 6339 with coolant through A/AD/B from DIN (ISO 7388-2-J/JD/JF)

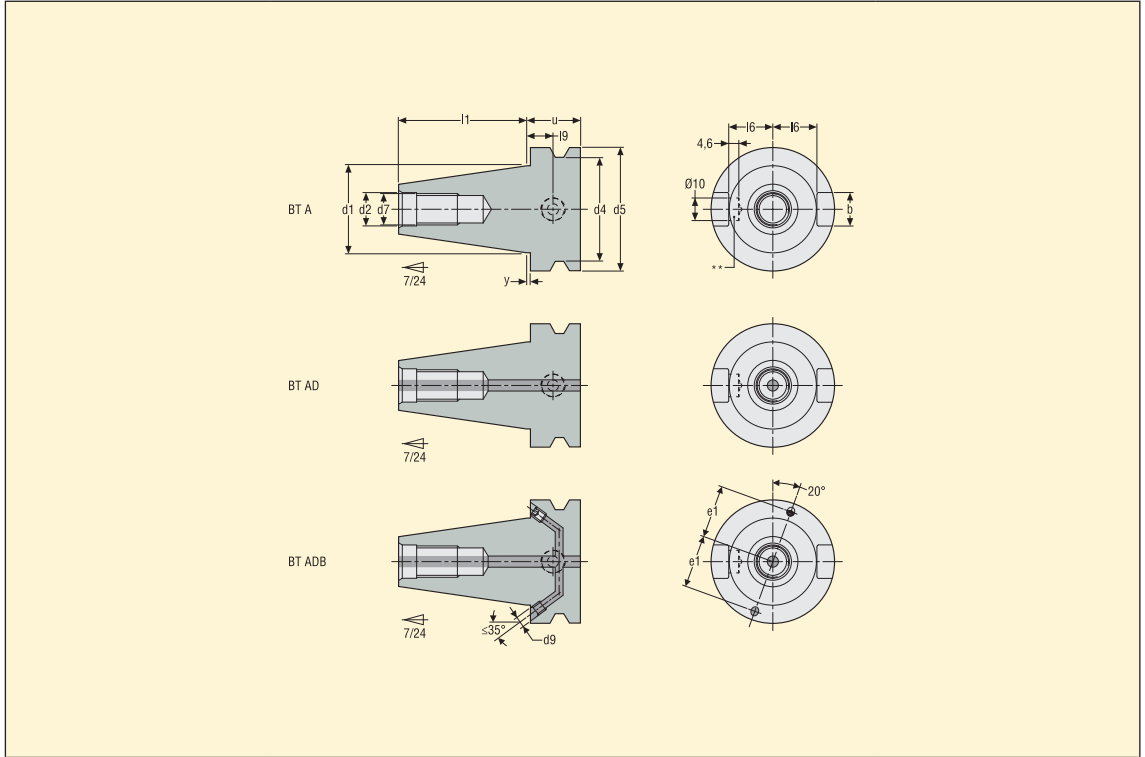

Machine side catalogue designation	Through coolant Form	Plugs**	Hole for RFID carrier***	Dimensions in mm												
				d ₁	d ₂	d ₄	d ₅ *	d ₇	d ₉	l ₁	l ₆	l ₉	e ₁	u	b	y
BT30	A/AD	–	No***	31,75	12,5	38	46	M12	–	48,4	16,3	11,0	–	22	16,1	2
BT40	A/AD	–	***	44,45	17,0	53	63	M16	–	65,4	22,5	14,5	–	27	16,1	2
BT40 ADB	A/AD/B	Screw	***	44,45	17,0	53	63	M16	4	65,4	22,5	14,5	27	27	16,1	2
BT50	A/AD	–	***	69,85	25,0	85	100	M24	–	101,8	35,4	20,5	–	38	25,7	3
BT50 ADB	A/AD/B	Screw	***	69,85	25,0	85	100	M24	6	101,8	35,4	20,5	42	38	25,7	3

Note: These machine side dimensions are applied to all the holders shown in the Product pages.

The B through coolant design of ADB holders is made according to DIN 69871-B.

* EPB BT holders with a front end diameter in excess of diameter d₅, are produced with a flange clearance length: BT30 = \varnothing 45 mm x 3 mm; BT40 = \varnothing 62 mm x 8 mm; BT50 = \varnothing 98 mm x 12 mm. This is compatible with the BT JIS norm which permits free dimensions on workpiece side.

** ADB type holders have two removable 'screws' in the flange, in order to realise all through coolant types A, AD, or B. Plugs (screws) are available as spare parts, see Product pages. For screw removing/re-fitting, see instructions on pages 26-27.

*** In order to know if a hole for RFID carrier exists, see 'RFID hole' column in Product pages: 1= hole for RFID carrier available, if required a carrier can be fitted on request, please enquire.

0= hole for RFID carrier not available, if required hole can be machined and a carrier can be fitted on request, please enquire.

BT with Taper-Face* tooling machine sides, dimensions

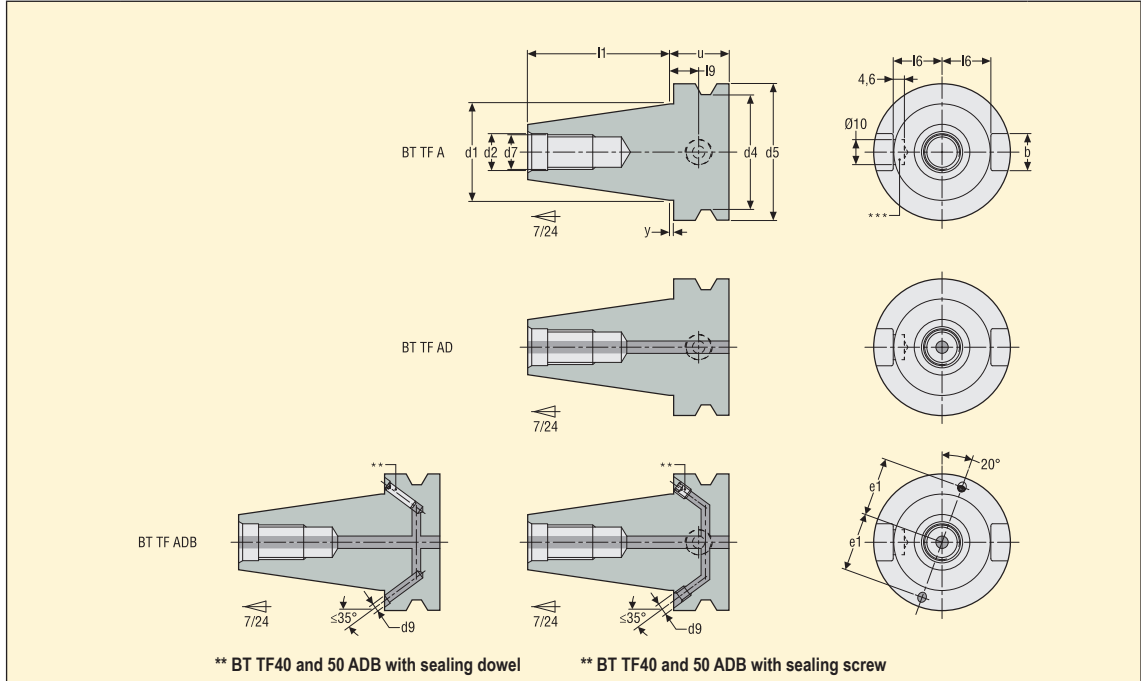

Machine side catalogue designation	Through coolant Form	Plugs**	Hole for RFID carrier***	Dimensions in mm												
				d ₁	d ₂	d ₄	d ₅ ****	d ₇	d ₉	e ₁	u	l ₁	l ₆	l ₉	b	y
BT TF30 AD	A/AD	–	No	31,75	12,5	38	46	M12	–	–	22	48,4	16,3	11	16,1	1,0
BT TF40 ADB	A/AD/B	Screw	Yes***	44,45	17,0	53	63	M16	4	27	27	65,4	22,5	14,5	16,1	1,0
BT TF40 ADB	A/AD/B	Dowel	No	44,45	17,0	53	63	M16	4	27	27	65,4	22,5	14,5	16,1	1,0
BT TF50 ADB	A/AD/B	Screw	Yes***	69,85	25,0	85	100	M24	6	42	38	101,8	35,4	20,5	25,7	1,5
BT TF50 ADB	A/AD/B	Dowel	No	69,85	25,0	85	100	M24	6	42	38	101,8	35,4	20,5	25,7	1,5

Note: These machine side dimensions are applied to all the holders shown in the Product pages.

* BT with Taper-Face tooling machine sides are:

– conform to the JIS B 6339 (ISO 7388-2) norm.

– except that they have a larger flange towards machine side, with tight tolerances: this achieves taper and face contacts on machine spindles with Taper-Face dimensions. Taper-Face tooling is also usable on standard spindles, but in that case a gap remains between spindle and flange faces.

** ADB type holders have two removable 'screws' or 'dowels' in the flange, in order to realise all through coolant types A, AD, or B. Plugs (screws or dowels) are available as spare parts, see Product pages. For screw removing/re-fitting and for dowel replacement, see instructions on page(s) 26-27.

*** In order to know if a hole for RFID carrier exists, see 'RFID hole' column in Product pages: 1= hole for RFID carrier available, if required a carrier can be fitted on request, please enquire.

0= hole for RFID carrier not available, if required hole can be machined and a carrier can be fitted on request, please enquire.

**** EPB BT holders with a front end diameter in excess of diameter d₅, are produced with a flange clearance length: BT30 = Ø 45 mm x 3 mm; BT40 = Ø 62 mm x 8 mm; BT50 = Ø 98 mm x 12 mm. This is compatible with the BT JIS norm which permits free dimensions on workpiece side.

Note : in the catalogue pages, we use as previously the short description 'BT' for BT JIS (ISO), and add 'TF' for these Taper-Face tooling machine sides. The exact machine side types can be recognised by Part No. code's 5 first digits E.... specifying the norm, the Taper-Face feature, the through coolant type, and the data carrier blind hole availability.

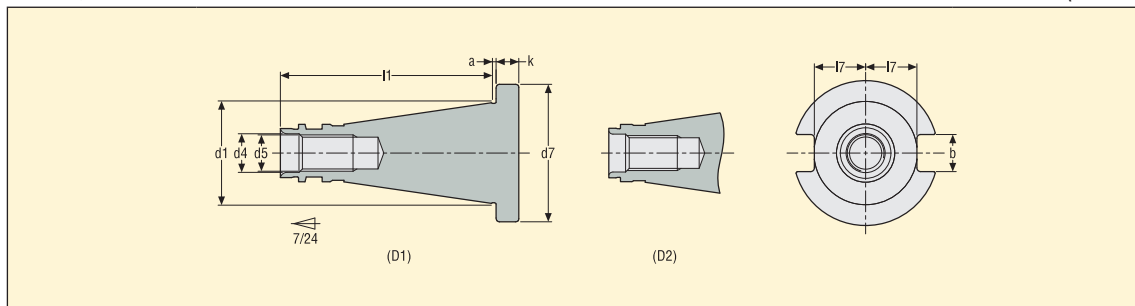

Machine side catalogue designation	Design (D)	Hole for RFID carrier*	Dimensions in mm								
			d ₁	d ₄	d ₅	d ₇	l ₁	l ₇	k	b	a
DIN(2080) 40	1	No*	44,45	17	M16	63,0	93,4	22,5	10	16,1	1,6
DIN(2080) 50	2	No*	69,85	26	M24	97,5	126,8	35,3	12	25,7	3,2

Note: These machine side dimensions are applied to all the holders shown in the Product pages.

Note: For pull studs to convert DIN 69871 and BT holders to DIN 2080 holders, see page(s) 304.

* No hole for RFID carriers. If required, hole can be machined and a RFID data carrier can be fitted on request, please enquire.

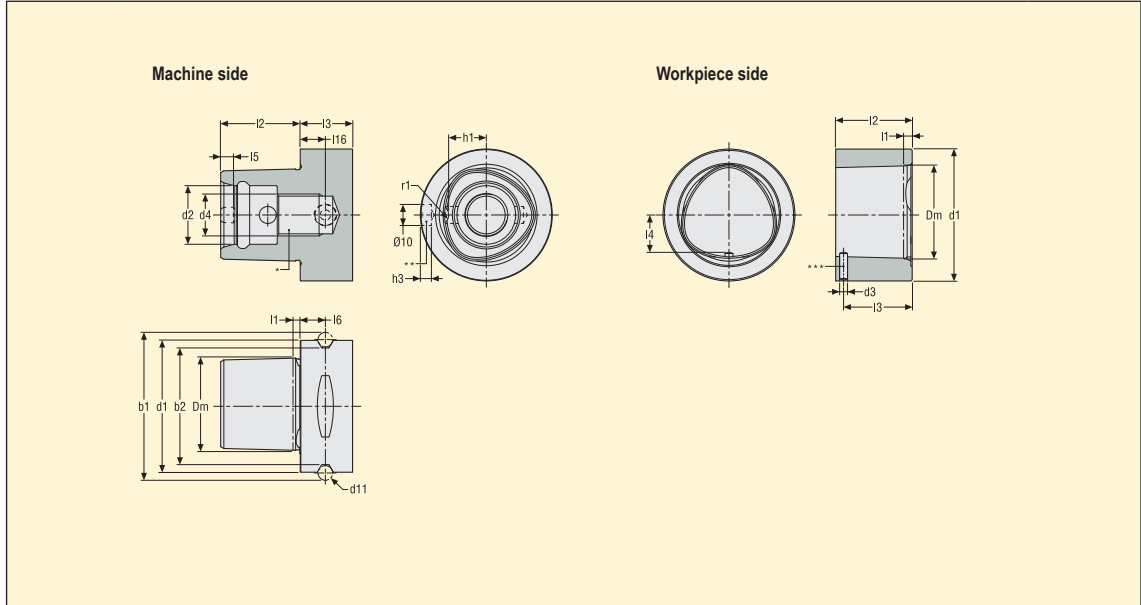

Machine side catalogue designation	Hole for RFID carrier**	Dimensions in mm															
		d ₁	d ₂	d ₄	d ₁₁	D _m	b ₁	b ₂	l ₁	l ₂	l _{3 min}	l ₅	l ₆	l ₁₆	h ₁	h ₃	r ₁
C3	No**	32	15	M12	5	22	39	28,3	2,5	19	15	3,2	6	9	9,0	5,4	3
C4	No**	40	18	M14	5	28	46	35,3	2,5	24	20	4,0	8	12	11,0	5,2	3
C5	**	50	21	M16	7	35	59,3	44,4	3,0	30	20	5,3	10	12	14,0	5,1	4
C6	**	63	28	M20	7	44	70,7	55,8	3,0	38	22	6,2	12	12	18,0	5,0	5
C8	**	80	32	M20	7	55	86	71,1	3,0	48	30	8,0	12	12	22,2	4,9	6

Workpiece side catalogue designation	Hole for RFID carrier**	Dimensions in mm						
		d _{1 min}	d ₃	D _m	l ₁	l ₂	l ₃	l ₄
C3	No	32	2,0	22	2,3	18,4	16,5	9,4
C4	No	40	2,5	28	2,3	23,4	21,0	11,5
C5	No	50	3,0	35	2,8	29,4	26,0	14,5
C6	No	63	4,0	44	2,8	37,4	33,5	18,5
C8	No	80	5,0	55	2,8	47,4	43,0	22,8

Note: These machine side and workpiece side dimensions are applied to all the holders shown in the Product pages.

* The Seco-Capto™ machine side of short extensions can only be hold by spindles with segment clamping (not with centre bolt clamping). The Seco-Capto™ machine side of short reducers can only be hold by spindles with segment clamping (not with centre bolt clamping).

** In order to know if a hole for RFID carrier exists, see 'RFID hole' column in Product pages: 1= hole for RFID carrier available, if required a carrier can be fitted on request, please enquire.

0= hole for RFID carrier not available, if required hole can be machined and a carrier can be fitted on request, please enquire.

*** Position pin: the style of the position pin may have a different design than in this figure. In some cases, the position pin may be omitted.

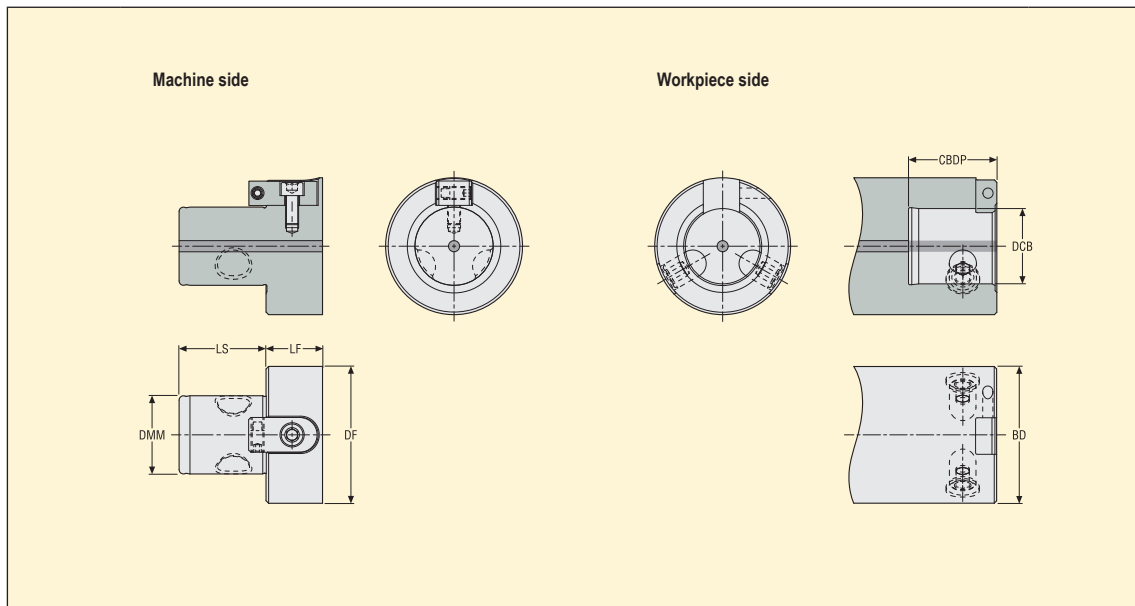

Machine side catalogue designation	Hole for RFID carrier*	Dimensions in mm		
		CBDP	DCB	BD
G0	No	16	8	12
G1	No	20	11	13
G2	No	25	14	16
G3	No	32	18	20
G4	No	40	22	24
G5	No	50	28	30
G6	No	63	36	40
G7	No	90	46	50

Workpiece side catalogue designation	Hole for RFID carrier*	Dimensions in mm			
		DF	DMM	LS	LF
G0	No	16	8	12	8
G1	No	20	11	13	9,5
G2	No	25	14	16	11
G3	No	32	18	20	14
G4	No	40	22	24	17
G5	No	50	28	30	20
G6	No	63	36	40	26
G7	No	90	46	50	26

Note: These machine side and workpiece side dimensions are applied to all the holders shown in the Product pages.

* No hole for RFID carriers

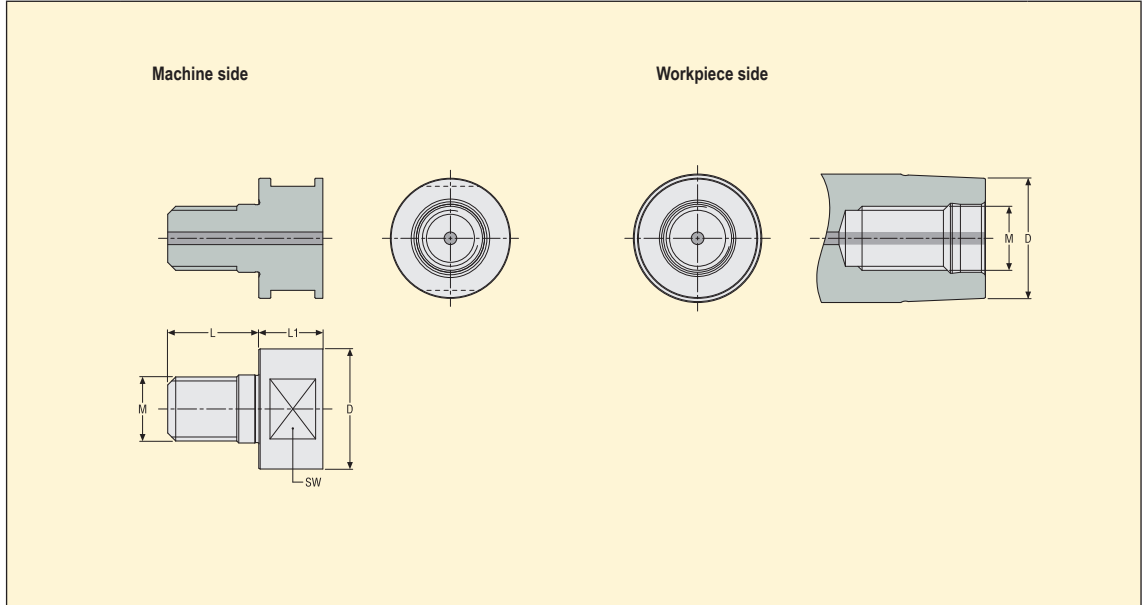

Machine side catalogue designation	Hole for RFID carrier*	Dimensions in mm				
		L	L ₁	D	M	SW
M6	No	13,5	9	11	6	9
M8	No	17,75	11	13,5	8	11
M10	No	18,75	13	18,5	10	15
M12	No	21,75	15	23	12	19
M16	No	22,75	16	30	16	26
M20	No	27	18	36,5	20	32

Workpiece side catalogue designation	Hole for RFID carrier*	Dimensions in mm	
		D	M
M6	No	11	6
M8	No	13,5	8
M10	No	18,5	10
M12	No	23	12
M16	No	30	16
M20	No	36,5	20

Note: These machine side and workpiece side dimensions are applied to all the holders shown in the Product pages.

* No hole for RFID carriers

Taper-Face (TF)

The Taper-Face (TF) tooling range allows Seco to completely equip machine-tools with Taper-Face steep tapers BT TF & Ansi TF. For less frequent Din TF, the range consists with only Steadyline® Combimaster and Seco-Capto™ workpiece sides.

Taper-Face versions are in each Machine side norm chapter's end.

Until now, Seco only had Taper-Face to Seco-Capto™ tooling.

The Taper-Face spindle system :

- Taper-Face tooling used on Taper-Face spindles achieve additional contact between spindle's face and holder's flange (vs. face/flange clearance with conventional steep taper fittings).
- How it is obtained:
 - TF Tooling : longer (+half clearance) and high precision flange dimensions and geometry.
 - TF Spindles: longer (+half clearance) and high precise face dimensions and geometry.
 - Higher pulling forces (compared to classic spindles) achieve flange contact with pressure, complementary to the taper fitting.

Advantages:

- Higher rigidity particularly profitable to long tooling and machining in difficult materials.
- Higher run-out precision and axial (length) repeatability.
- Taper-Face tooling can be used on conventional steep taper spindles but loosing the face contact advantages.



Standard taper

Taper-Face contact

Sealing screws and sealing dowels removal instructions

ADB type tooling holders have two removable sealing screws or sealing dowels in the flange, in order to realise all through coolant types A, AD, or B. Plugs (screws or dowels) are available as spare parts :

- Sealing screws Part No 950A0406 for taper size 40 and Part No 950A0606 for taper size 50 : see below for instructions. Sealing screws are reusable.
- Sealing dowels Part No 564301701 for taper size 40 and Part No 564301702 for taper size 50 : see below for instructions. Sealing dowels are for single use only !

Sealing screws

Sealing screws removal instructions:

For B through coolant (flange through coolant), the two originally fitted sealing screws in holder's machine side flange have to be removed, and a non through coolant pull stud has to be used so as to seal the back of the holder.

For AD through coolant (central 'draw bar' through coolant), the two sealing screws in holder's machine side flange have to be in place, and a through coolant pull stud has to be used.

Sealing paste required for sealing screw mouting is not available from Seco-EPB: we recommend 'LOCTITE 577 - Thread sealing paste'.

Sealing screws mounting instructions:

After cleaning or on a new sealing plug, apply sealing paste onto thread*. Screw sealing screw until its back face is flush with holder's flange. Sealing to moderate pressure is obtained instantly; the maximum pressure resistance is reached after 24 hours (100 bar maximum - see also sealing paste's directions for use).

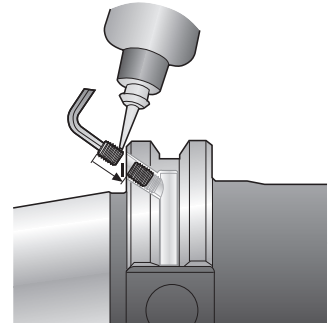

Sealing dowels

Sealing dowels removal instructions:

1. The tool holders are delivered in coolant through form AD (1.1): the channels in holders for coolant through form B are sealed with two dowels made from a plastic body locked by a screw (1.2 & 1.3).



Fig 1.1

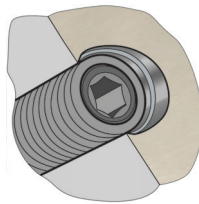

Fig 1.2

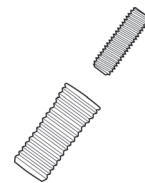

Fig 1.3

2. For B through coolant, remove the two sealing dowels:

- 2.1 Remove the two locking screws with a hex key size 1,5mm.
- 2.2 Mount two hexagon socket head screws M3, 1,5 to 2 turns into dowels plastic body.
- 2.3 With a pliers, pull out screw and dowels body.

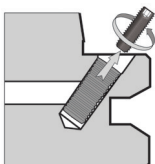

Fig 2.1



Fig 2.2

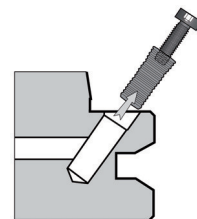

Fig 2.3

Sealing dowels replacement instructions:

3.1 Sealing dowels, available as spare parts are for single use only.

3.2 Introduce the two new sealing dowels plastic body, without screw, completely into the two through coolant channels by using an assembly tool, the dowels must not stand out of the flange.

3.3 Screw completely the two locking screws with a hex key size 1,5 mm.

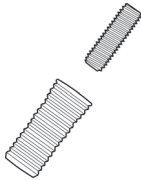

Fig 3.1

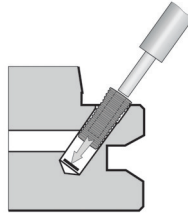

Fig 3.2

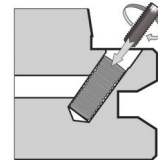

Fig 3.3

3.4 B type coolant channels are sealed again

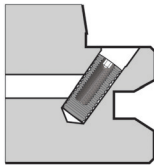

Fig 3.4

Steadyline® damping system, general information

The patented Steadyline® damping system

A built-in vibration absorber dampens the vibrations as soon as they are transmitted by the cutting tool to the body of the holder. It prevents them from spreading along the bar, thus limiting the deflection of the milling assembly.

As a result, Steadyline® vibration damping holders offer up to three times greater dynamic rigidity than equivalent solid holders.

The holders are ready to use, and offer the damping advantages regardless the type of rotating or static machining operation, the number of teeth in the cutter or the workpiece material.

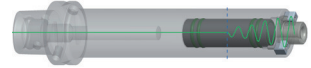

Productivity booster

The Steadyline® vibration damping system allow longer assemblies, much higher cutting conditions, with quieter operation and optimum stability. Key benefits are increased productivity, improved surface finish and longer tool and spindle life.

Problem solver

Steadyline® holders are particularly recommended for:

- Milling and turning operations with long overhangs with predominantly radial forces.
- Machining of deep cavities in mould and die workpieces.
- Machining of complex monolithic (one piece) workpieces, particularly in the aerospace, automotive and power generation industries.

Steadyline® tooling range

For milling, standard holders with Steadyline® damping systems are available with Combimaster and Shell mill tool connections. For internal turning, threading and boring, the standard range of bars features either a quick change GL connection or BA connection for an easy and repeatable assembly of turning or boring heads (shown in the MN Turning and MN Holemaking).

Steadyline® damping is also widely applicable on custom made tooling and tools, please inquire.



Steadyline® shell mill holders: productivity booster

The standard Steadyline® shell mill holders enable machining up to 10xD overhang with cutting speeds similar to short assemblies, hence increasing depth of cut ap by up to 3 times compared to classic long holders : the chip removal rate can be drastically increased ! For longer assemblies, please enquire.

For recommended cutting conditions, see Instructions page.



Other features

- Types:** Steadyline® shell mill holders type 5555 are cylindrical and 5556 are conical shaped for increased stiffness. Workpiece side for tenon drive milling cutters is designed with large bearing face and through the spigot multi-channel coolant supply.
- Run-out:** Direct run-out of the spigot in relation to the external taper is 5 µm maximum.
- Balancing** See Product pages 'Balancing column'.

Shell mill holders, Steadyline®, main operating instructions

This page summarises the instructions delivered with the holders, as a pre-information. To ensure optimal use of the Steadyline® shell mill holders, the detailed operating instructions delivered with the holder must be respected.

Note: The built-in damping system is ready to use, whatever the milling operation, the number of teeth in the cutter or the workpiece material.

Milling cutter fitting

Due to the high cutting conditions achievable, a reliable clamping of the milling cutter onto the Steadyline® holder must be realised as below:

–Centre bolt with suitable length: For optimal use, the centre bolt has to stand out from the milling cutter back face (LFN-LF) (see table).

–Centre bolt tightening torque: Apply the recommended centre bolt tightening torque (see table).

DMM (mm)	TDZ (mm)	LFN-LF (mm)	Tightening torque (Nm)
16	8	3-4	30
22	10	6-8	40
27	12	8-10	60
32	16	12-16	80
40	20	17-22	108

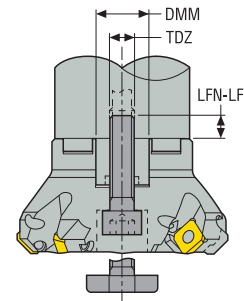

Recommended cutting conditions and maximum temperature

Make sure to never exceed the maximum RPM of the holder (indicated on the holder and listed in the table).

- Too high cutting conditions could cause vibrations of the milling assembly, this would prevent the damper operating properly and would damage the tool, the tool holder, the machine as well as the workpiece: set the cutting conditions in order to stay vibration free.

Optimal cutting conditions, selection procedure:

1. Cutting speed v_c and feed f : select the average values recommended for the cutter and inserts.

2. The width of cut a_e and the depth of cut a_p maximum are the parameters to fine tune. It is possible to increase them inside cutter and inserts recommendations, while staying vibration free.

BEWARE: contrary to the use of classic long holders, the machining cannot be stabilised through additional radial force (e.g. by raising the feed).

Make sure the Steadyline® holder body never exceeds a maximum temperature when in use of 80° C.

DMM (mm)	Max. RPM	Operating temperature
16	8 000	80° C
22	8 000	
27	6 000	
32	4 000	
40	3 000	

Shell mill holders

- Types:** EPB 5525, 5524 and 552 – Holders for tenon drive milling cutters. EPB 5525 and 5524 are with directional coolant channels through the spigot.
- Norm:** EPB 5525: Spigot and tenon drive features according to ISO 3937, but with larger bearing face OD than ISO (according to most recent cutters, for optimized rigidity). EPB 5524 and 552, ISO 3937: **small bearing face OD suitable for e.g. disc mill cutters Type B.** EPB 5525 with $\varnothing 40$ have 4 threaded holes according to DIN 6357 in addition to the central locking bolt.
- Run-out:** Direct run-out of the spigot in relation to the external taper is 5 μm maximum.
- Balancing:** See Product pages 'Balancing column'.
- Accessories:** When the cutter has no through coolant channels, it is possible to replace the standard cross head centre bolt by a cross head centre bolt with through coolant channels shown in Accessories. This will direct the coolant towards the cutter's workpiece side.

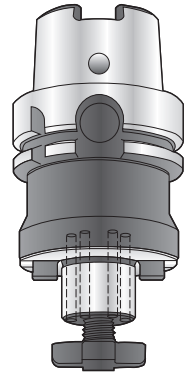

Milling cutter holders, flange mounting

- Types:** EPB 569 – For large diameter face mill cutters. Offering a large bearing face and secure locking using 4 screws according to DIN 2079. High torque transmission thanks to large driving keys.
- Norm:** DIN 6357/DIN 2079.
- Run-out:** Direct run-out of the spigot in relation to the external taper is 5 μm maximum.
- Balancing:** See Product pages 'Balancing column'.

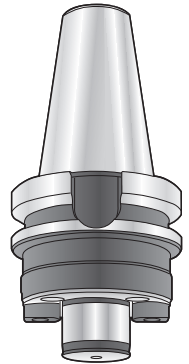

Disc mill holders

Types: EPB M5656, 5657 – The disc mill is held by an adjustable sliding shaft arbor equipped with a driving key. The arbor and disc mill are locked using a pulling screw. Slim workpiece side clamping flange for optimised accessibility.

Norm: Suitable for e.g. Seco disc mill cutters Type A.

Balancing: See Product pages 'Balancing column'.



Side lock holders, Weldon

Types: EPB 584 – The tool position is fixed as a result of the tool shank flat(s) and cannot be adjusted. The locking method offers high torque transmission. Bore sizes \varnothing 16, 20, 25, 32 and 40 mm have the machine side face ground in order to be 'Seco-Weldon' tool shanks compatible.

Norm: DIN 1835-2 Form B/ISO 5414-1.

Tool shanks: Weldon DIN 1835-1 Form B/ DIN 6535 Form HB.

Run-out: Direct run-out of the workpiece side bore to the machine side taper is 3 μ m.

Balancing: See Product pages 'Balancing column'.

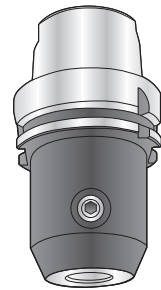

Side lock holders, Weldon short

Types: EPB 5842 – Shortest Weldon side lock workpiece side design, giving maximum rigidity. Bore sizes \varnothing 16, 20, 25 and 32 mm have the machine side face ground in order to be 'Seco-Weldon' tool shanks compatible.

Norm: Compatible to DIN 1835-1 Form B/ISO 5414-1 but not conformed.

Tool shanks: Weldon DIN 1835-1 Form B/ DIN 6535 Form HB.

Run-out: Direct run-out of the workpiece side bore to the machine side taper is 5 μ m.

Balancing: See Product pages 'Balancing column'.

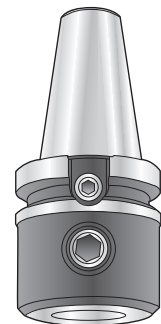

Shrinkfit holders, general information

A Shrinkfit tool holder works in conjunction with a specialised heating device e.g. Easyshrink®. Holder's bore in which the tool locates is slightly undersized compared to the tool shank. Heating the holder opens up this bore, allowing the tool to be inserted. As the holder cools, the bore shrinks around the tool to create a concentric and rigid clamping. Bore size \varnothing 3 mm to 32 mm (\varnothing 0.11" to 1.25").

Thermal expansion:

Approx. 11 $\mu\text{m}/\text{m}/^\circ$ for steel and HSS

Approx. 6 $\mu\text{m}/\text{m}/^\circ$ for carbide and heavy metal

e.g.: \varnothing 20, heating from 20°C to 270°C

Steel: 0,020 x 11 x 250 = + 55 μm

Carbide: 0,020 x 6 x 250 = + 30 μm

Shrinkfit holders, all available workpiece side types

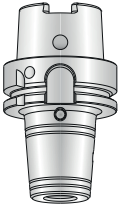

EPB 5603/5403

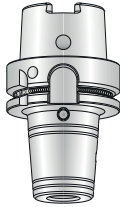

EPB 5403M

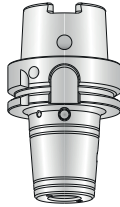

EPB 5600

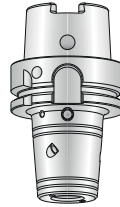

EPB 5600P

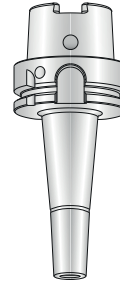

EPB 5801



EPB 5801

Suitable tool shank types and tolerances for Shrinkfit holders

Cylindrical DIN 1835-1 Form A/ DIN 6535 Form HA.

Note: Type 5600P requires the Safe-Lock™ shank execution (grooves). Types EPB 5403M, EPB 5403M1 and EPB 5403M2 are designed for MQL (Minimum Quantity Lubrication), tools according to standard DIN 69090-3.

Tool shank tolerance required

\varnothing 3 to 5 mm (\varnothing 0.11" to 0.19") maximum h5, tool shank must be carbide or heavy metal (e.g. Densimet). \varnothing 6 to 32 mm (\varnothing 0.23" to 1.25") maximum h6, tool shank can be steel, HSS, carbide or heavy metal. Using h5 for \varnothing 6 to 32 mm (\varnothing 0.23" to 1.25") provides a safer minimum clamping torque. Make sure the minimum shrinking depth LSC shown in the product pages for each holder is respected when fitting the tool shank into the holder.

Run-out

Maximum run-out when measured at a gauge projection of 3 x \varnothing DCB (DCB = bore dia. referred to DCBN-DCBX in Product pages) in relation to the machine side taper or shank is 3 μm maximum.

Direct run-out of the holder workpiece side bore in relation to the machine side taper or shank is 3 μm maximum.

Balancing

Shrinkfit holders are mostly balanced as standard, see Product pages.

Heat resistance

EPB Shrinkfit holders are made from heat resistant steel guaranteeing structure, geometry and dimensional stability after many Shrinkfit heating cycles. The maximum acceptable temperature is 400°C.

DIN type Shrinkfit holders, EPB 5603/5403 (specific features)

See also Guide page 'Shrinkfit holders, general information'.

Designation 'EPB 5603' is used for all DIN type Shrinkfit holders, except HSK-A63 and HSK-A100 being 'EPB 5403'.

EPB 5603/5403 has a 4,5° nose angle, an internal thread for a stop screw (stop screw delivered with the holder) and 4 balancing threaded holes, according to norm DIN 69882-8.

The stop screw has hexagonal machine and workpiece sides and a coolant through channel with front groove.

Note: When using the stop rods from Easyshrink® 20 Shrinkfit devices for tool length setting, there is no need for a stop screw.

Norm DIN 69882-8 also defines the overall dimensions of some HSK-A Shrinkfit holder type 5603/5403 sizes (marked with an asterisk in the Product pages): for the other type EPB 5603/5403 holders, this norm only applies to the workpiece side shape, the thread for a stop screw and a stop screw delivered with the holder, and the 4 balancing threaded holes.

Holders type EPB 5603/5403 with diameters 3 to 5 mm as well as extra short holders have neither thread for stop screw (no stop screw delivered) nor balancing threaded holes, due to lack of space (see information in Product pages). Holders type EPB 5603 with Combimaster and with Seco-Capto™ machine side connections have no balancing threaded holes.



Transmittable torque to the tool shank (Nm) and Max RPM, Shrinkfit holders EPB 5603/5403

Clamp ∅ (mm)	Minimum static transmittable torque (Nm)	Shrinkfit clamping system Max RPM*
6	18 Nm	45 000
8	35 Nm	45 000
10	65 Nm	40 000
12	110 Nm	40 000
14	150 Nm	38 000
16	200 Nm	38 000
18	250 Nm	35 000
20	320 Nm	35 000
25	500 Nm	32 000
32	550 Nm	30 000

* 1/ The maximum RPM for holders equipped with this clamping system is often restricted by the holder's machine side taper type and size.

2/ MQL Shrinkfit holders: to guaranty a good efficiency of the MQL coolant flow, Max RPM for MQL Shrinkfit holders can be lower.

See page(s) 36.

A kit of balancing screws for Shrinkfit holders EPB 5603/5403 and EPB 5600 is available as Accessories (Part N° 90ZQ01)

The kit contains screws of different masses, to be fitted into holder's balancing threaded holes of Shrinkfit holders type EPB 5603/5403 and EPB 5600.

Balancing screws allow fine tune balancing of Shrinkfit holders and tool assemblies when using a suitable balancing machine. The appropriate balancing screws are meant to be screwed until stop in the threaded holes, with a torque of 1 Nm.



MQL type Shrinkfit holders, EPB 5403M, EPB 5403M1 and EPB 5403M2 (specific features)

See also Guide page ‘Shrinkfit holders, general information’.

MQL technology

MQL (Minimum Quantity Lubrication) is a ‘near-dry’ coolant solution, consisting in a mix of air and oil. Suitable tool holders for MQL must be equipped with specific MQL coolant tubes and MQL stop screws.

Two MQL technologies are available in our standard range:

- MQL1: the ‘air and oil’ mix is produced before entering the machine spindle and delivered to the tool through one channel (hence the name “MQL1”) that goes through the machine spindle, the tool holder and the tool.

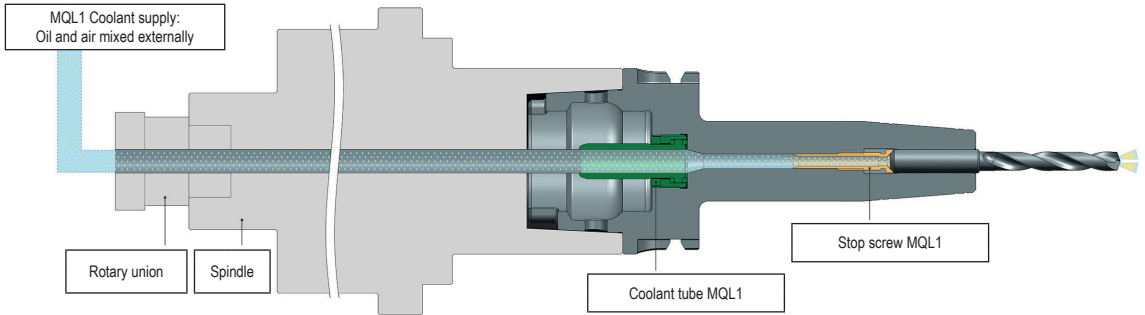

MQL1

- MQL2: The air and the oil are delivered through 2 distinct channels (hence the name “MQL2”) up to the MQL2 coolant tube, where they are mixed in tube’s chamber.

MQL2 coolant tubes, featuring a connecting pipe, and MQL2 stop screws are needed.

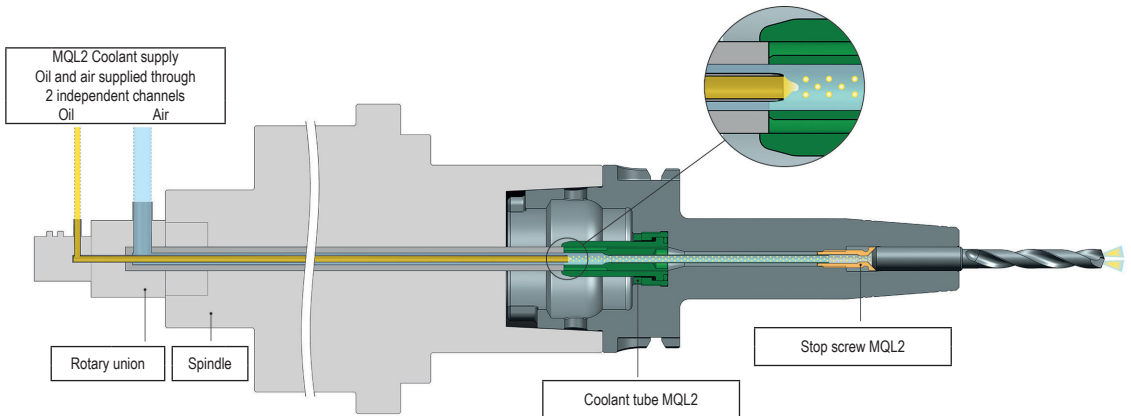

MQL2

MQL holders, delivered without accessory (EPB 5403M) or ready for MQL1 (EPB 5403M1) or ready for MQL2 (EPB 5403M2)

Three HSK-A MQL Shrinkfit tool holder ranges are available:

‘M’ delivered without accessories, ‘M1’ delivered with MQL1 accessories fitted and ‘M2’ delivered with MQL2 accessories fitted. A “MQL” laser marking is added in their HSK-A flange, to differentiate MQL types Shrinkfit holders from standard DIN non MQL type Shrinkfit holders (according to standard DIN69882-8).

All components used in M1 and M2 holders can be ordered separately as accessories to equip M holders.

Type EPB 5403M

Shrinkfit holders, according to standard DIN 69090-3, designed for MQL1 and MQL2. Accessories to be ordered separately.

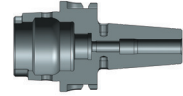

Type EPB 5403M1

Shrinkfit holders ready for MQL1, delivered with MQL accessories fitted. MQL1 Shrinkfit holders, coolant tubes and stop screws according to standard DIN 69090-3.

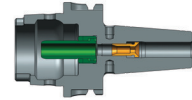

Type EPB 5403M2

Shrinkfit holders ready for MQL2, delivered with MQL accessories fitted. MQL2 Shrinkfit holders body according to standard DIN 69090-3. MQL2 coolant tubes and stop screws patented by Bielomatik.

Several combinations "tool holder + stop screw + coolant tube" are proposed: the optimal combination is depending on the cutting tool (shank diameter, number and a cross-section of coolant channels).

"4:1 rule": To guaranty an optimal delivery of the MQL2 flow to the cutting edge, a cross-sectional ratio of 1:1 to 4:1 between the section of the coolant tube's pipe (ADIF1) and the sum of the tool coolant channels' sections (A_{TOOL}) is required. If several combinations are possible, it is recommended to privilege the combination with the ratio the closest to 1:1, to optimize the MQL flow.

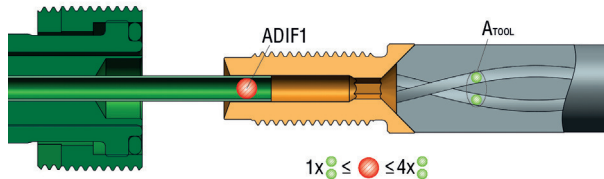
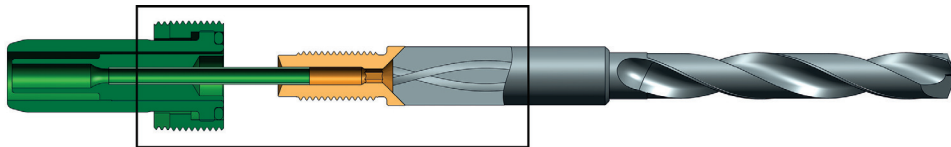
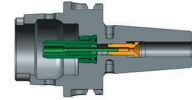

A_{TOOL} (mm ²)	∅ ADIF1 (mm ²)
0 - 1,6 mm ²	2,01 mm ²
1,4 - 3,0 mm ²	4,15 mm ²
2,5 - 6,5 mm ²	9,08 mm ²
5,5 - 16,6 mm ²	16,62 mm ²

Max RPM, Shrinkfit holders in MQL configuration

Clamp ∅ (mm)	Shrinkfit clamping system	
	Max RPM* MQL1	Max RPM* MQL2
6	16 000	40 000
8	16 000	40 000
10	16 000	40 000
12	16 000	40 000
14	16 000	38 000
16	16 000	38 000
18	16 000	35 000
20	16 000	35 000
25	16 000	32 000
32	16 000	30 000

* The maximum RPM for holders equipped with this clamping system is often restricted by the holder's machine side taper type and size.

Minimum transmittable torque are the same as the ones for EPB 5603/5403 (see previous pages).

Accessories for MQL1

Accessories for MQL1 according to standard DIN 69090-3.

Please refer to EPB 5403M1 Shrinkfit holders product pages for selection of MQL1 accessories.

MQL1 Coolant tubes

HSK-A63, MQL1 Shrinkfit holders need a conventional coolant tube 20E9304, as available for DIN type Shrinkfit holders.

HSK-A100, MQL1 Shrinkfit holders need a specific coolant tube 20E9306M1: the internal diameters are optimized for MQL flow.



MQL1 Stop screws

Stop screws for MQL1 feature a tapered face, for efficient contact with tapered MQL tool shanks, according to standard DIN 69090-3.



Accessories for MQL2

Please refer to EPB 5403M2 Shrinkfit holders product pages for selection of MQL2 accessories.

MQL2 Coolant tubes

MQL2 coolant tubes feature a connecting pipe that connects and slides in the stop screw to warranty an optimal delivery of the MQL2 mix to the tool shank. A variety of MQL2 coolant tubes is available, with different coolant pipe lengths and diameters (cross-section ADIF1). Selection of the appropriate coolant tube: please refer to "4:1" rule (see above, paragraph "Type EPB 5403M2").



MQL2 Stop screws

Stop screws for MQL2 feature a tapered face, for efficient contact with tapered MQL tool shanks. A variety of stop screws is available, with several coolant channels diameters for each tool diameter.

Beware: make sure to select matching MQL2 coolant tubes and MQL2 stop screws, with identical ADIF1 value.



Shrinkfit holders, reinforced, EPB 5600 (specific features)

See also Guide page ‘Shrinkfit holders, general information’.

Reinforced design:

The Shrinkfit front part OD dimensions are one size wider compared to type 5603. The body part from flange to Shrinkfit front is conical reinforced.

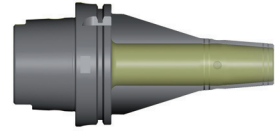

Periphery through coolant channels, with removable plugging screws:

When using tools without through coolant, remove the plugging screws to direct coolant towards the cutting edges.

The reinforced design achieves up to 40% more tool transmittable torque and higher rigidity, for increased productivity and quality performances. The coolant supply directed towards the cutting edges increases tool life.



Other specific design features of EPB 5600

Shrinkfit front with 4,5° nose angle (similar to DIN EPB 5603 holders but one size wider).

Internal thread for a stop end screw. A stop end screw is delivered with the holder (similar to DIN type 5603 holders). The stop end screw features a central hole and a concave front face for through coolant with tools with through coolant.

4 balancing threaded holes for balancing screws (similar to DIN type 5603 holders). A kit of balancing screws is available as accessories, see guide page of EPB 5603 Shrinkfit holders.

Due to their dimensions (lack of space), some holders type 5600 don't have threads for stop screws (no stop screw delivered) or no balancing threaded holes (see information in Product pages).

The coolant channels design and numbers achieve high coolant flow: 2 channels up to \varnothing 20 mm, 3 channels for \varnothing 25 and 32 mm.

Coolant channel plugs are designed to be fitted without using additional equipment. Plug removal is easy and reliable.

The reinforced workpiece side of EPB 5600 Shrinkfit holders require a specific heating program on the Easyshrink® 15 and 20 Shrinkfit devices.

Transmittable torque to the tool shank (Nm) and Max RPM of EPB 5600

Clamp \varnothing (mm)	Minimum static transmittable torque (Nm)	Shrinkfit clamping system Max RPM*
6	25	45 000
8	48	45 000
10	90	40 000
12	150	40 000
16	280	38 000
20	420	35 000
25	620	30 000
32	750	25 000

* The maximum RPM for holders equipped with this clamping system is often restricted by the holder's machine side taper type and size.

Shrinkfit holders, EPB 5600 Safe-Lock™ (specific features)

See also Guide page ‘Shrinkfit holders, general information’.

The EPB 5600 Safe-Lock™ Shrinkfit holders combine a pull-out protection system for round shanked cutting tools with the highly accurate Shrinkfit clamping.

Safe-Lock™ tool pull-out protection system:

Drive pins are fitted into the Shrinkfit toolholder bores. In combination with spiral-shaped grooves of the cylindrical cutting tool shank, the pins prevent the tool from being pulled-out of the chuck during extreme machining. Most SECO Jabro-HPM solid end mills now can be ordered with Safe-Lock™ shank execution (grooves) on demand.

Safe-Lock™ is the solution against tool pull-out effects, it:

- secures the tool clamping,
- avoids tool ejection, workpiece scrapping, and damage on machine spindle,
- ensures optimum process reliability and longer tool life
- increases productivity as the milling cutter can be used with its maximum cutting data.

Using the EPB 5600 Shrinkfit design

Safe-Lock™ Shrinkfit holders use the EPB 5600 reinforced Shrinkfit design : see EPB 5600 Guide pages.

Differences EPB 5600 Safe-Lock™ vs EPB 5600:

Tools require the Safe-Lock™ shank execution.

Stop end screw fitted in the holder vs in delivery content.

Due to their dimensions (lack of space), some EPB 5600 Safe-Lock™ holders don't have threads for stop screw and therefore no stop screw, and/or no balancing threaded holes (see information in Product pages).



Max RPM, Shrinkfit holders EPB 5600 Safe-Lock™

Clamp Ø (mm)	Shrinkfit clamping system Max RPM*
12	45 000
16	38 000
20	35 000
25	30 000
32	25 000

* The maximum RPM for holders equipped with this clamping system is often restricted by the holder's machine side taper type and size.



Suitable tool shanks, to be:

Cylindrical DIN 1835-1 Form A/ DIN 6535 Form HA with Safe-Lock™ shank execution.

SAFE-LOCK™
by HAIMER.

Mould and Die type Shrinkfit holders, EPB 5801 (specific features)

See also Guide page ‘Shrinkfit holders, general information’.

Mould and Die Shrinkfit holders, EPB 5801 available in Monobloc and as cylindrical extension (see Operating & setting accessories).

Long and slim 5°/3° nose angle design, with coated external surface. Designed to be particularly suitable for Mould & Die application.

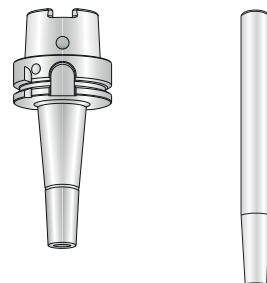

High precision collet chucks, EPB 5672

Type:

EPB 5672 – High performance collet chuck system combining high run-out precision, high transmittable torque and HSM suitability.

Run-out:

Maximum run-out, in relation to holder's machine side taper is 3 µm when measured with an ER HP collet at a gauge projection of 3xd (up to a maximum of 50mm).

Suitable collets ER HP type 5672:

The high precision collet chucks EPB 5672 require a specific range of collets ER HP type 5672, see Operating & setting accessories.

The collet designation 'ER HP' indicates that the collet type 5672 is based on the external design of ISO 15488-B (ER), but equipped with a distinguishing blue plastic ring in the locking groove to avoid confusing it with a classic ER collet that would not provide the run-out mentioned above.

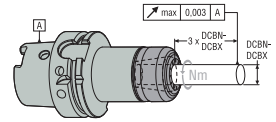

Transmittable static torque to the tool shank (Nm)

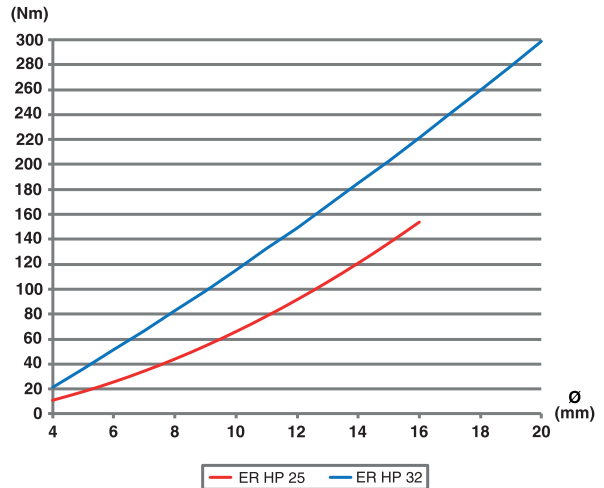
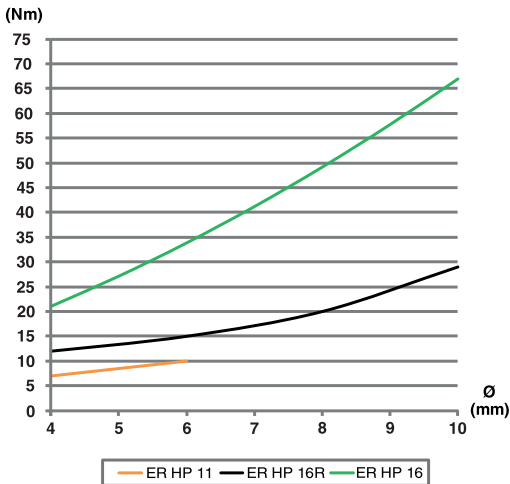

Transmittable static torques when collet nuts are tightened at Max. torque.

Balancing:

See Product pages 'Balancing column'.

Norm:

No norm.

Tool shanks:

Cylindrical DIN 1835-1 Form A/ DIN 6535 Form HA.

Tool shank diameter to be similar to collet's bore (no clamping capacity) and tolerance h10 maxi.

Through coolant supply:

1/ When using 'not sealed' collets and no stop end screw, the coolant flows through the collet's grooves, along the tool shank.

2/ To direct the coolant through the tool shank, two solutions are available:

- sealing obtained by using a concave tapered stop end screw available as Accessories (for tool shanks without groove)
- sealing obtained by using sealed collets (available as Operating & setting accessories).

Stop end screw:

High precision collet chucks are delivered as standard without stop end screws. Stop end screws are not recommended for high spindle speeds, e.g. over 10 000 rpm. When using a stop end screw, its tapered contact onto the tool shank can increase the tool run-out defect. Stop end screws have to be ordered separately, see Accessories.

High precision collet chucks, EPB 5672 (cont.)

Roller spanners are required to tighten and release the plain cylindrical collet nuts of EPB 5672 chucks. Classic roller spanners and torque roller spanners are available as Accessories, to be ordered separately.

The use of a torque spanner is recommended for collet nut tightening: reliable application of the recommended clamping torque guarantees high transmittable torque to the tool and prevents nut or collet deformation.

For nut releasing, it is recommended to use a classic spanner: Torque spanner's handle mechanism could be damaged by possible required higher untightening torque compared to the set torque for tightening.



Torque roller spanner, Tip/Handle



Classic roller spanner

Recommended tightening torque for the collet nut

Collet chuck size	Capacity DCBN-DCBX mm	Recommended tightening torque*
HP 11	1-7	10 Nm
HP 16R	1	10 Nm
	1,5-3,5	15-20 Nm
	4-10	25-30 Nm
HP 16	1	10 Nm
	1,5-3,5	25-30 Nm
	4-10	50-55 Nm
HP 25	2-3	25-30 Nm
	3,5-6,5	35-40 Nm
	7-10	55-60 Nm
	10,5-16	80-90 Nm
HP 32	2-3	30-35 Nm
	3,5-6,5	55-60 Nm
	7-15,5	110-120 Nm
	16-20	130-140 Nm

* For nut tightening and releasing, both key types hook and roller (torque spanner and classic spanner) are available as Accessories, see Product Pages and detailed description of the roller spanners in chapter Operating & setting accessories.

High precision type clamping system Max RPM

Collet chuck size	Capacity DCBN-DCBX mm	HP type clamping system Max RPM*
HP 11	1-7	50 000
HP 16R	1-10	50 000
HP 16	1-10	60 000
HP 25	2-16	42 000
HP 32	2-20	30 000

* The maximum RPM for holders equipped with this clamping system is often restricted by the holder's machine side taper type and size.

Operating instructions: To ensure optimal use of the high precision collet chucks, the detailed operating instructions delivered with the holder must be respected.

Hydraulic chucks, general information

Hydraulic clamping system

An internal piston pressurises hydraulic fluid into a chamber surrounding the holder bore. The high pressure is uniformly applied to grip 360° around the tool shank. Cutting tools are held with excellent precision. The bore has a helical groove where dirt, oil or grease can collect when it has inadvertently been left on the tool shank. The pressurising screw must be tightened until stop using the dedicated key available as Accessories (see Product pages).

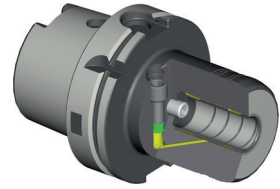

PLEASE NOTE: Never lock the chuck without a tool in place. This would damage the chamber and make the chuck unusable.

Suitable for internal coolant supply through the stop screw.

Tool shanks accepted

Cylindrical	Weldon	Weldon	Whistle Notch
	∅ 6 mm - ∅ 20 mm	∅ 25 mm - ∅ 32 mm	
OK	OK	NO	NO

Additional tool shank diameters can be clamped using reduction sleeves (see further).

Tool shank tolerances accepted

h6 maximum

Balancing

See Product pages 'Balancing column'.

Control gauges for hydraulic chucks, see Operating & setting accessories

To check that the pressure of hydraulic chucks remains sufficient, it is recommended to regularly test the chucks with suitable gauges, shown in chapter Operating & setting accessories.

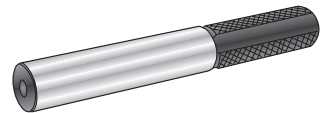

Hydraulic chuck control instructions summary, using a control gauge:

Insert the control gauge into the chuck.

Tighten the clamping screw until you cannot turn the control gauge.

Then it should be possible to complete a minimum of full turns of the pressurising screw, before completely tightening:

- EPB 5834: minimum of 3 full turns (2,5 turns for ∅ 6 mm and 8 mm)
- EPB 5831: minimum of 4 full turns
- EPB 5835: minimum of 5 full turns

This will confirm that the clamping capability is adequate.

Note: Detailed control instructions are part of the operating instruction sheet delivered with the hydraulic chucks.

Reduction sleeves for hydraulic chucks, see chapter Operating & setting accessories

The reduction sleeves for hydraulic chucks act as split collets allowing more shank types and sizes to be gripped in a same chuck.

The run-out with the sleeve is:

- EPB 5834: maximum 5 µm at 3 x ØDCBN-DCBX
- EPB 5831: maximum 8 µm at 3 x ØDCBN-DCBX
- EPB 5835: maximum 6 µm at 3 x ØDCBN-DCBX

Tool shanks accepted, when using reduction sleeves

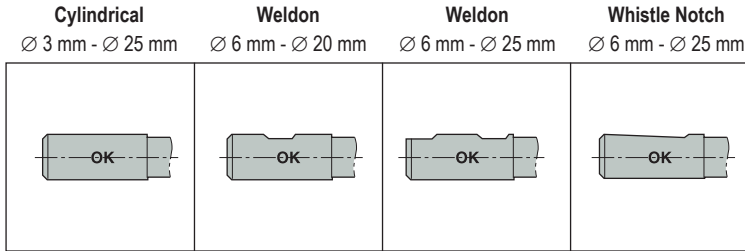

Reduction sleeves, range (see also chapter Operating & setting accessories)

For tool shank Ø mm	Reduction sleeves OD Ø 12 mm	Reduction sleeves OD Ø 20 mm	Reduction sleeves OD Ø 32 mm
	Designation	Designation	Designation
3	05F5832 12 03	05F5832 20 03	–
4	05F5832 12 04	05F5832 20 04	–
5	05F5832 12 05	05F5832 20 05	–
6	05F5832 12 06	05F5832 20 06	05F5832 32 06
8	05F5832 12 08	05F5832 20 08	05F5832 32 08
10	05F5832 12 10	05F5832 20 10	05F5832 32 10
12	–	05F5832 20 12	05F5832 32 12
14	–	05F5832 20 14	05F5832 32 14
16	–	05F5832 20 16	05F5832 32 16
18	–	–	05F5832 32 18
20	–	–	05F5832 32 20
25	–	–	05F5832 32 25

Hydraulic chucks, EPB 5834 (specific features)

See also Guide page 'Hydraulic chucks, general information'

A good choice for HSM and high precision. It is not recommended where high radial forces are involved due to its lower radial rigidity. An internal piston pressurises hydraulic fluid into a chamber surrounding the holder bore. The high pressure is uniformly applied to grip 360° around the tool shank. Cutting tools are held with excellent precision. The bore has a helical groove where dirt, oil or grease can collect when it has inadvertently been left on the tool shank. The pressurising screw must be completely tightened.

PLEASE NOTE: NEVER LOCK THE CHUCK WITHOUT A TOOL IN PLACE.

Types: EPB 5834 – DIN 69882-7 defines the overall dimensions of some HSK-A hydraulic chuck holder sizes, refer to the Product pages. For the other hydraulic chuck holder types and sizes this norm only applies to the workpiece side.

Tool shanks: Cylindrical DIN 1835-1 Form A/ DIN 6535 Form HA, \varnothing 6 to 32 mm and Weldon DIN 1835-1 Form B/ DIN 6535 Form HB, \varnothing 6 to 20 mm (see chapter Operating & setting accessories)..

Cylindrical OK	Weldon OK	Weldon NO	Whistle Notch NO
	\varnothing 6 mm - \varnothing 20 mm	\varnothing 25 mm - \varnothing 32 mm	

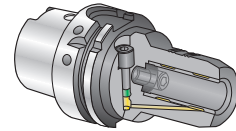

Shank tolerance
h6 maximum.

Run-out
Maximum run-out when measured at a gauge projection of 3 x DCBN-DCBX in relation to the external taper is 3 μ m.

Balancing
See Product pages 'Balancing column'.

Clamp \varnothing (mm)	Minimum static transmittable torque (Nm)	Operating temperature	Max. coolant pressure	Hydraulic system Max RPM*
6	20	10-50° C	70 bar	40 000
8	30			40 000
10	40			40 000
12	70			40 000
14	100			40 000
16	120			40 000
18	140			40 000
20	170			40 000
25	200			25 000
32	250			25 000

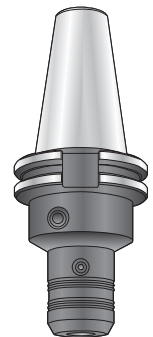

* The maximum RPM for holders equipped with this clamping system is often restricted by the holder's machine side taper type and size.
To reach maximum transmittable torque, the tool shank and bore must be clean and dry.

Hydraulic chucks, EPB 5831, slim (specific features)

See also Guide page ‘Hydraulic chucks, general information’

Designed with a long and slim workpiece side profile, the EPB 5831 is ideal for drilling operations or finishing and semi-finishing milling operations where access is restricted by narrow cavities in the workpiece (eg. for Mould & Die applications). These slim hydraulic chucks are fine balanced to make them suitable for HSM, while the hydraulic system offers a damping effect during machining.

Chucks are delivered with a length setting stop end screw with a coolant channel with front groove.

An internal piston pressurises hydraulic fluid into a chamber surrounding the holder bore. The high pressure is uniformly applied to grip 360° around the tool shank. Cutting tools are held with excellent precision. The bore has a helical groove where dirt, oil or grease can collect when it has inadvertently been left on the tool shank. The pressurising screw must be tightened until stop.

PLEASE NOTE: NEVER TIGHTEN THE CHUCK WITHOUT A TOOL IN PLACE.

This would damage the chamber and make the chuck unusable.

Tool shanks: Suitable tool shanks for direct fitting: Cylindrical DIN 1835-1 Form A/ DIN 6535 Form HA, \varnothing 6 to 12 mm and Weldon DIN 1835-1 Form B/ DIN 6535 Form HB, \varnothing 6 to 12 mm. Additional tool shank diameters can be clamped using reduction sleeves (see next page or chapter Operating & setting accessories).

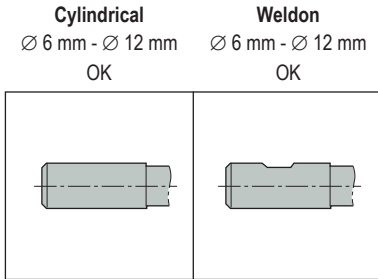

Shank tolerance

h6 maximum.

Run-out

Maximum run-out when measured at a gauge projection of 3 x \varnothing DCBN-DCBX in relation to the external taper is 5 μ m.

Balancing

See Product pages ‘Balancing column’.

Clamp \varnothing (mm)	Minimum static transmittable torque (Nm)	Operating temperature	Max. coolant pressure	Hydraulic system Max RPM*
6	20	10-50° C	50 bar	40 000
8	30			40 000
10	40			40 000
12	70			40 000

* The maximum RPM for holders equipped with this clamping system is often restricted by the holder’s machine side taper type and size.

To reach maximum transmittable torque, the tool shank and bore must be clean and dry.

Hydraulic chucks, EPB 5831, slim (cont.)

Control gauges, see chapter Operating & setting accessories

To check that the pressure of hydraulic chucks remains sufficient, it is recommended to regularly test the chucks with suitable gauges, shown in chapter Operating & setting accessories.

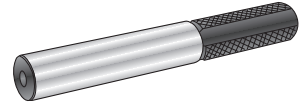

Hydraulic chuck EPB 5831 control instructions summary, using a control gauge:

Insert the control gauge into the chuck.

Tighten the clamping screw until you cannot turn the control gauge.

Then it should be possible to complete a minimum of four full turns of the pressurising screw, before completely tightening.

This will confirm that the clamping capability is adequate.

Note: Detailed control instructions are part of the operating instruction sheet delivered with the hydraulic chucks.

Reduction sleeves for hydraulic chucks, see chapter Operating & setting accessories

The reduction sleeves for hydraulic chucks act as split collets allowing more shank types and sizes to be gripped (see below).

The run-out of EPB 5831 chucks with a sleeve is maximum 8 µm at 3 x ØDCBN-DCBX.

Suitable tool shanks when using reduction sleeves:

Cylindrical

Ø 3 mm - Ø 10 mm

OK

Weldon

Ø 6 mm - Ø 10 mm

OK

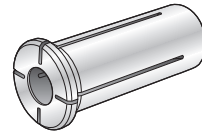
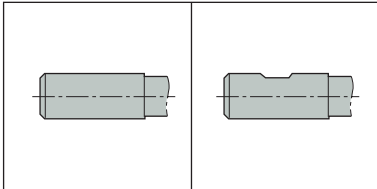

Hydraulic chucks, EPB 5835, strong (specific features)

See also Guide page ‘Hydraulic chucks, general information’

Description:

Hydraulic chucks, strong type, for High Performance Cutting are specially designed to combine rough milling capabilities at low runout. Allowing higher cutting data thanks to the high transmittable torque, a great rigidity due to short design and a hydraulic system that minimizes vibration during machining.



Run-out

Maximum run-out when measured at a gauge projection of 3 x \varnothing DCBN-DCBX in relation to the external taper is 4 μ m.

Clamp \varnothing (mm)	Minimum static trans- mittable torque (Nm)	Operating temperature	Max. coolant pressure	Hydraulic system Max RPM
12	200	10-50°C	70 bars	30000
16	300			30000
20	450			25000
25	600			25000
32	1000			18000

* The maximum RPM for holders equipped with this clamping system is often restricted by the holder's machine side taper type and size. To reach maximum transmittable torque, the tool shank and bore must be clean and dry.

ER collet chucks

- Types:** EPB 5675 – offers good flexibility thanks to the interchangeability of the collets. The clamping range of an ER collet is up to 1 mm.
- Norm:** ISO 15488.
- Tool shanks:** Cylindrical DIN 1835-1 Form A/ DIN 6535 Form HA.
- Run-out:** Maximum run-out when measured with a collet at a gauge projection of 3 x DCBN-DCBX in relation to the external taper is 10 µm.
- Balancing:** See Product pages 'Balancing column'.

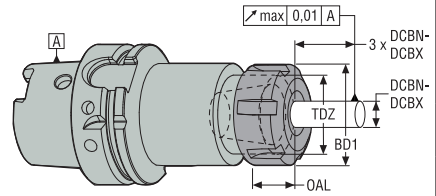

Recommended tightening torque for the locking nut

Collet chuck size	BD1 mm	OAL mm	TDZ	Max tightening torque*
ER16	32	18	M22 x 1,5	60 Nm
ER25	42	21	M32 x 1,5	110 Nm
ER32	50	23	M40 x 1,5	160 Nm
ER40	63	26	M50 x 1,5	180 Nm

* For nut tightening and releasing, both key types hook and roller (torque spanner and classic spanner) are available as Accessories, see Product Pages and detailed description of the roller spanners in chapter Operating & setting accessories.

Through coolant supply:

- There are two possibilities to direct the coolant through the tool shank coolant channel(s) when fitted into an ER collet chuck:
- by applying the concave front face of the stop end screw equipping the ER collet chucks onto the tool shank (for tool shanks without groove)
 - by using a sealing nut, available as Accessories, and a sealing ring, available as Operating & setting accessories. Sealing nuts are slightly longer than standard nuts, see lengths listed in Product pages.

ER collet chuck extensions, with cylindrical shank, Operating & setting accessories

Types: **EPB 5450** – these collet chuck extensions have a cylindrical shank, tolerance h5. They can be used where there is restricted access, when a long reach is required or to hold small tools. Extensions in sizes ER08R, ER11R, ER16R and ER25R are equipped with reduced diameter locking nuts.

Norm: ISO 15488.

Tool shanks: Cylindrical DIN 1835-1 Form A/ DIN 6535 Form HA.



Run-out: Maximum run-out when measured with a collet at a gauge projection of 3 x DCBN-DCBX in relation to the cylindrical shank is 15 µm (18 µm with the smallest ER 08).

Balancing: See Product pages 'Balancing column'.

Recommended tightening torque for the locking nut

Collet chuck size	BD1 mm	OAL mm	TDZ	Max tightening torque*
ER08R	12	11	M10 x 0,75	12 Nm
ER11R	16	12	M13 x 0,75	25 Nm
ER16R	22	18	M19 x 1	35 Nm
ER25R	35	20	M30 x 1	45 Nm
ER32	50	23	M40 x 1,5	160 Nm

* For nut tightening and releasing, both key types hook and roller (torque spanner and classic spanner) are available as Accessories, see Product Pages and detailed description of the roller spanners in chapter Operating & setting accessories.

OZ collet chucks

Types: EPB 5873 – Flexibility thanks to the interchangeability of collets. Ball bearing type locking nut.

Norm: DIN 6388.

Tool shanks: Cylindrical DIN 1835-1 Form A/ DIN 6535 Form HA.

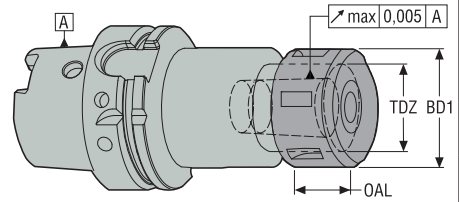

Run-out: Maximum run-out when measured with a collet and at a gauge projection of 3 x DCBN-DCBX in relation to the external taper is 15 µm, see OZ collets Guide and Product pages - Operating & setting accessories.

Balancing: See Product pages 'Balancing column'.

Recommended tightening torque for the locking nut

Collet chuck size	BD1 mm	OAL mm	TDZ mm	Max tightening torque*
OZ32	72	33,5	M60 x 2,5	140 Nm

* For nut tightening and releasing, both key types hook and roller (torque spanner and classic spanner) are available as Accessories, see Product Pages and detailed description of the roller spanners in chapter Operating & setting accessories.

Adjustable drill chucks

Types: EPB 5085 – Compact one piece design, allowing both CW or CCW spindle rotation. Clamping is made through a side access screw and gear mechanism.

Norm: No norm.

Tool shanks: Cylindrical DIN 1835-1 Form A/ DIN 6535 Form HA.

Run-out: Maximum run-out when measured at a gauge projection of 2,5 x DCBN-DCBX in relation to the external taper is 40 µm for diameters from 2 mm. No run-out precision guarantee for diameters lower than 2 mm.

Balancing: See Product pages 'Balancing column'.

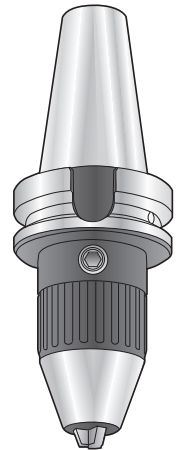

Recommended tightening torque for the locking screw

Clamp capacity Ø (mm)	Minimum transmittable torque to the tool shank	Max tightening torque
1-13	80 Nm	10-15 Nm
2,5-16	120 Nm	10-15 Nm

Tapping chucks with micro-compensation, for synchronized tapping, EPB 5867

EPB 5867 – Improves tapping performances during synchronized tapping. The inbuilt axial micro flexure (+/- 0,5 mm) prevents from tap stress, which may appear from micro-deviation of the synchronism between the spindle rotation, feed and tap pitch. That micro-compensation mechanism offers longer tap life, protects tap against breakage, increases productivity and improves thread quality.

Product range starts at size ER 11 'tap size M2' and goes up to size ER 50 'tap size M48'.

Suitable ER tapping collets with square drive:
offering precise tap holding and positive torque transmission.

Tool shanks:
Cylindrical tap shanks with a square machine side.

Balancing:
See Product pages 'Balancing column'.

Through coolant supply:
Chucks EPB 5867 feature a through coolant design. Maximum coolant pressure 80 bar.

Suitable sealing rings:
The chucks are delivered with collet clamping nuts allowing the fitting of sealing rings, available as Operating & setting accessories (except for ER 11 size).

The rings prevents coolant to flow though the collet's grooves, forcing coolant to flow through the tap's coolant channel.

Assembly instructions:
The use of two dedicated keys, available as Accessories (see Product Pages) will provide the recommended tightening torque (see table below) and is recommended to eliminate the risk of damaging the micro-compensation system or the tap driver: the locking key (Part No. 5680092-xx) is used to maintain the micro-compensation mechanism in position while the spanner (Part No. 03B5875xx) is used to tighten the nut. Do not tighten the nut without maintaining the micro-compensation mechanism in position, even if the EPB 5867 tapping chuck is maintained in a Tool Boy assembly support.



Recommended tightening torque for the ER tapping collet nuts

Tapping chuck size	Max tightening torque*
ER 11	30 Nm
ER 20	100 Nm
ER 25	130 Nm
ER 40	220 Nm
ER 50	260 Nm

* For nut tightening and releasing, both spanner types: hook and roller (torque spanner and classic spanner) are available as Accessories, see Product Pages and detailed description of the roller spanners in chapter Operating & setting accessories.

Adjustable drill holders

- Types:** EPB BM/6100-6101 – These holders allow SECO Perfomax® drills to be radially offset from centre.
Available for R7 drill shanks, ISO 9766, \varnothing 25, 32 and 40.
Reduction sleeves are available as Accessories, see chapter Operating & setting accessories.
- Norm:** No norm.
- Run-out:** Offset is adjusted by rotating the holder's internal sleeve and then locking.
– Adjustable +0,8 to -0,3 mm on diameter.
– Adjustability graduations in increments of 0,05 mm on diameter.
– Maximum radial adjustment for the drills is shown in Machining Navigator Holemaking.
- Balancing:** See Product pages 'Balancing column'.

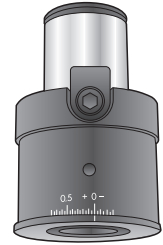

Greenstock blanks, available in Monobloc and Graflex®

- Types:** EPB 5023 – The taper/flange and Graflex® connection are case hardened and ground.
The cylindrical front part 120 to 130 daN/mm² tensile strength it is not hardened and can be machined by the customer.
Subsequent heat treatment is not recommended.
- Norm:** No norm.
Used for special (custom-made) tooling.
- Balancing:** See Product pages 'Balancing column'.



Control bars, available in Monobloc

- Types:** EPB 586 – Test bars are used primarily for checking the accuracy and to set the axes of the machine tool and tool presetter.
- Norm:** No norm.
- Accuracy:** Direct run-out between front part and taper 5 μm maximum. Measurement values are tabulated on the accompanying datasheet and certificate of accuracy.

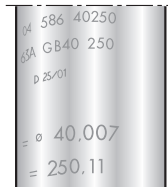
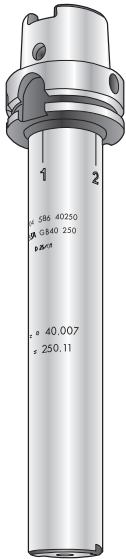

Diameter and length measurement values are laser engraved on each test bar.

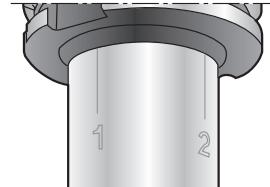

Measurement positions are laser engraved.

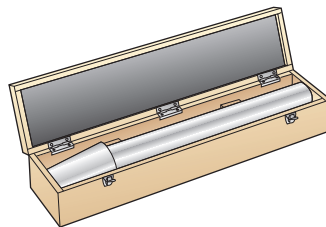

Delivered in a protective case.



The front leading edge can be used for optical presetting.

The modular milling solution for medium size cutters

Combimaster tooling and tools achieve optimum access and shortest overhang.

Stability, precision and balance are improved vs. classic assemblies, e.g. Weldon or collet chucks. Extensions and reducers to realise optimum tool length.

Combimaster arbors are available with most machine sides (HSK, DIN, BT, ANSI, Seco-Capto™, Cylindrical), see Product pages.

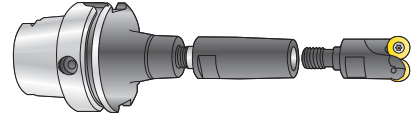

Balancing quality

The balancing quality of each tool holder is shown in its Product page balancing column.

Simplified codes “G2.5”, “G6.3”, “PB” and “-” are used and correspond to:

“G2.5”: Individually balanced at G2,5-25.000 rpm

“G6.3”: Individually balanced at G6,3-20.000 rpm. Can be balanced to G2,5-25.000 on request, please enquire.

“PB”: Pre-balanced by design. Most of the pre-balanced holders can be fine balanced on request, please enquire.

“-”: not balanced

Combimaster arbors, code key

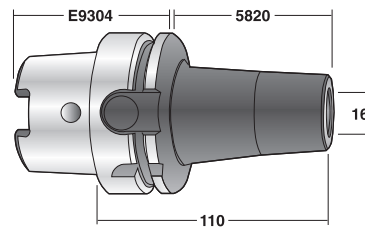
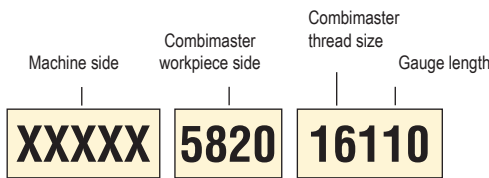

Combimaster arbors, workpiece side types

HSK-A, HSK-E, DIN, BT, Seco-Capto™, Graflex® (...) adapters are shown as part of the respective chapters, where tool holders are grouped per machine side connections.

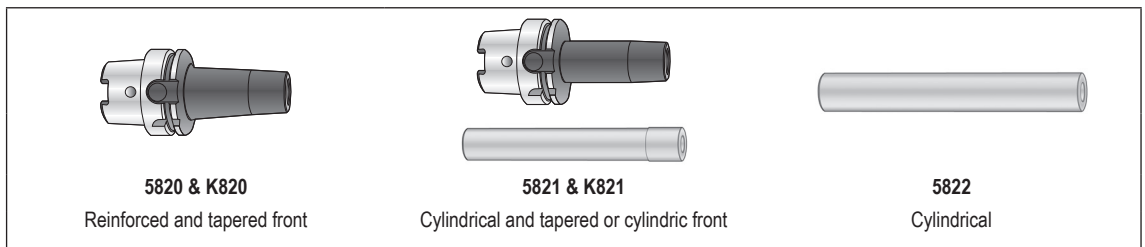

Combimaster recommended tightening torques

Combimaster size M	Tightening torque	Tightening key size SW (mm)
M6	10 Nm	9
M8	25 Nm	11
M10	40 Nm	15
M12	60 Nm	19
M16	80 Nm	26
M20	120 Nm	32

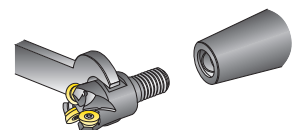

Combimaster cutter heads

Note: Combimaster cutter heads are shown in MN Milling catalogue.

Steadyline® vibration damping Combimaster arbors, EPB K820/K821

See also Guide page 'Combimaster arbors, General information'.

See also Guide page 'Steadyline® vibration damping system, General information'.

Steadyline® Combimaster arbors complete the Steadyline® range of milling holders, between shell mill and Shrinkfit Steadyline® holders.

Combimaster assemblies achieve optimum access to the workpiece. Stability, precision and balance are improved vs. classic assemblies, e.g. Weldon or collet chucks. Steadyline® vibration damping Combimaster arbors are a patented solution to boost your productivity or offer you a solution in long overhang situations.

Steadyline® Combimaster holders are available in several length projections, long (often available as an alternative to the same conventional Combimaster holder's length) and longer (adding longer projections to the range of conventional Combimaster arbors).

Steadyline® Combimaster holder types



EPB K820
Steadyline® Combimaster
entirely tapered



EPB K821
Steadyline® Combimaster
cylindrical and front tapered

EPB K820

Steadyline® Combimaster arbors are tapered to provide the best compromise between rigidity and accessibility to the workpiece.

EPB K821

Steadyline® Combimaster arbors have a cylindrical body profile for a slimmer access to the workpiece.

Balancing

Pre-balanced : see Product pages 'Balancing' columns.

Steadyline® Combimaster arbors, main operating instructions

This summarises the instructions delivered with the arbors, as a pre-information.

Combimaster arbors with Steadyliner® vibration damping system are designed to directly hold Combimaster heads. Addition of Combimaster intermediates is not recommended, as it will reduce the damper's effect.

Note: Combimaster cutter heads are shown in Machining Navigator Milling.



Recommended cutting conditions and maximum temperature

Make sure never to exceed the maximum RPM of the arbors (indicated on the arbors and listed in the Product pages).

Inappropriate cutting conditions could cause vibrations of the milling assembly, this would prevent the damper operating properly and would damage the tool, the tool holder, the machine as well as the workpiece: set the cutting conditions in order to stay vibration free.

Optimal cutting conditions, selection procedure:

- 1. Cutting speed V_c and feed f :** select the average values recommended for the cutter and inserts.
- 2. The width of cut a_e and the depth of cut a_p are the parameters to fine tune.** It is possible to increase them inside cutter and inserts recommendations, while staying vibration free.

BEWARE: contrary to the use of classic long holders, the machining cannot be stabilised through additional radial force (e.g. by raising the feed).

Make sure the Steadyliner® Combimaster holder body never exceeds a maximum temperature of 80°C when in use.

ER to Combimaster arbors

Compact, this tooling system allows face, side and disc milling operations via Combimaster milling cutters as opposed to solid end mills. This achieves higher material removal rates due to larger cutting diameter capacities and shorter overhangs.

The adapters are ready to use assemblies made of an ER OD shaped collet, assembled into a nut with a ball bearing.

To be fitted onto ER machine spindles eg. turrets of turning machines, or onto ER collet chucks.

Available as standard in three ER machine side sizes and five Combimaster workpiece side sizes. Further ER and Combimaster sizes are available on request, please enquire.

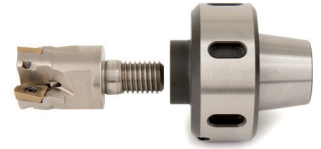

Cutter diameter comparison when using an ER collet or an ER to Combimaster arbor. Recommended tightening torque for the ER collet nut compared to the Combimaster tool tightening.

Cutter Ø comparison				Tightening torque	
ER Collet size	ER Collet bore Ø mm	Combimaster size	Cutting Ø mm for side and face milling	ER Collet nut tightening torque*	Combimaster tool tightening torque
ER 25	1-16 mm max.	M8	16 mm	60 Nm	25 Nm
		M10	20 mm		40 Nm
		M12	25 mm		60 Nm
ER 32	2-20 mm max.	M10	20 mm	90 Nm	40 Nm
		M12	25 mm		60 Nm
		M16	32 mm		80 Nm
ER 40	3-26 mm max.	M12	25 mm	120 Nm	60 Nm
		M16	32 mm		80 Nm
		M20	40 mm		120 Nm

* For nut tightening and releasing, both key types hook and roller (torque spanner and classic spanner) are available as Accessories, see Product Pages and detailed description of the roller spanners in chapter Operating & setting accessories.

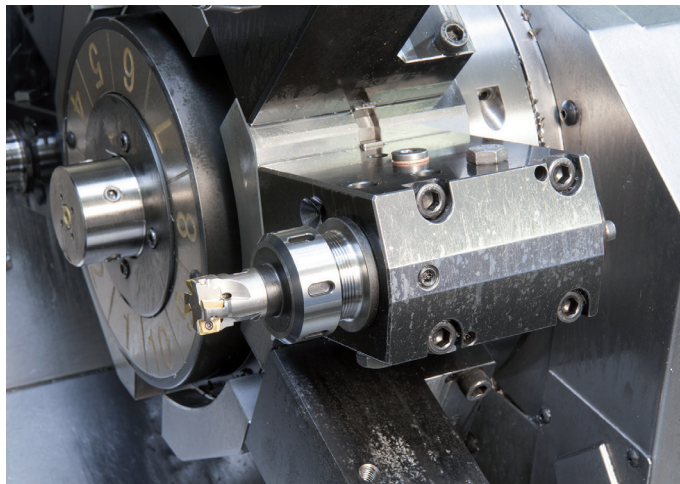

Multi-task machine, rotating turret with ER spindle, equipped with an ER to Combimaster adapter and a Combimaster milling cutter.

A complete range of modules, suitable for all machines and all machining operations

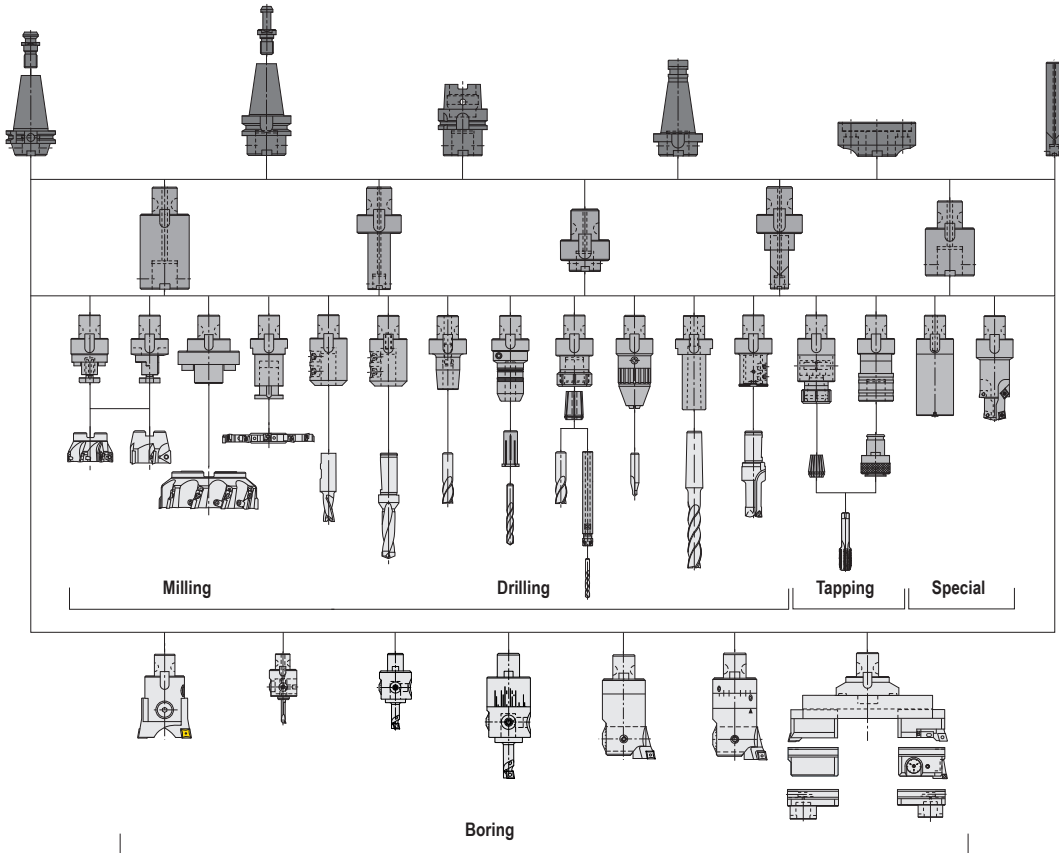

A modular tooling range for flexibility and performance

Flexibility:

Tooling of variable lengths and diameters can rapidly be built together, when they are needed. Graflex® modules e.g. tool holders and boring heads, as well as cutting tools can be fitted on all types of machines, by the substitution of only the basic Graflex® arbors, available in variety of machine side connections (HSK-A, HSK-E, DIN, BT, Seco-Capto™ ...).

The Graflex® modules are suitable for milling, drilling, tapping, reaming and boring.

Performance:

The connection rigidity and precision, enables Graflex® assemblies to be used in similar machining conditions as the same sized Monobloc holders. The wide range of modules permits tooling dimensions closest to the required machining operation, for optimised cutting conditions.

All basic arbors, extensions and reducers, main tool holders and all boring heads have through coolant possibilities.

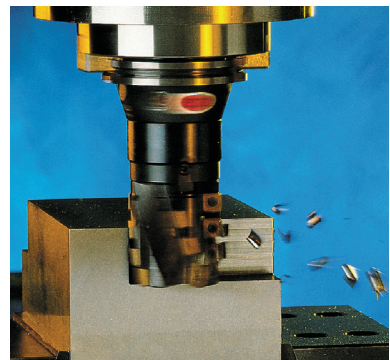

Power milling with Graflex® Modular Tooling:
metal removal rate 432 cm³/min

The Graflex® connection (patented)

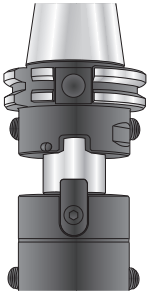

The long spigot and face connection, combined with EPB's production quality, masters all machining requirements, e.g. strength and precision in milling as well as in boring.

Radial access to the locking screws = easy handling.

High face contact pressure which can be enhanced by self-locking of the connection during machining = improved rigidity.

Graflex® is a registered trademark of Seco-EPB.

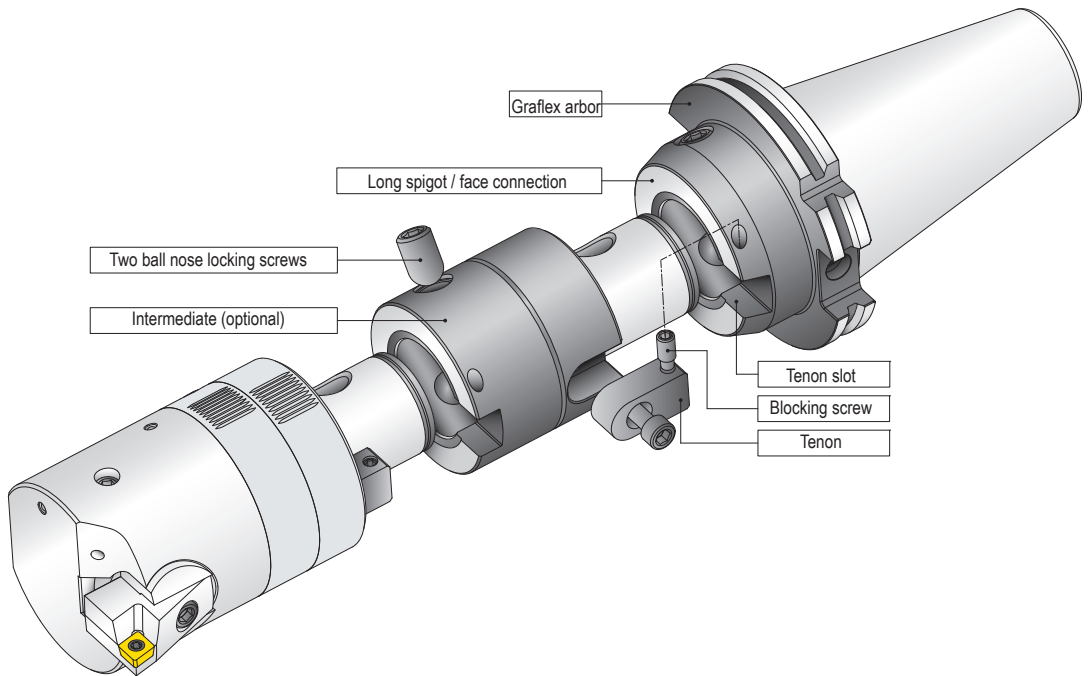

Graflex® self locking feature

Strong machining torque e.g. during boring may create micro rotational movement of the spigot in relation to the bore, causing micro displacement of the ball nose screw's contact surfaces. This results in complementary self-locking of the connection, enhancing the system's rigidity (Drawing 3).

For operations involving intermittent cutting e.g. heavy milling, the blocking screw provided in the tenon can be tightened so as to avoid micro rotational movement and prevent self locking (Drawing 4).

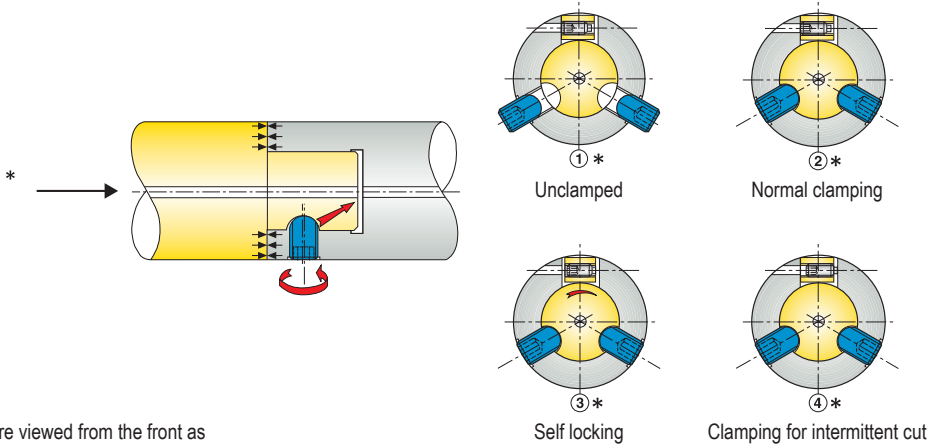

*Drawings 1, 2, 3 and 4 are viewed from the front as when normally assembled e.g. when using the Tool Boy assembly support.

'Optimised' Graflex® assembly procedure

<p>left face</p>	<ol style="list-style-type: none"> 1. Clean the parts to be assembled and apply thin oxidation protection film. 2. Position the Graflex® arbor and module(s) using the tenon(s) for easy orientation. 3. Tighten the ball nose locking screws ensuring that the left face of the tenon contacts the left face of the tenon slot. 4. Lightly tighten screw A 5. Lightly tighten screw B 	<p>left face</p>
<p>Normal clamping for continuous cut, e.g. boring, light duty milling</p> <ol style="list-style-type: none"> 6. 'Torque' screw A (low values). 7. 'Torque' screw B (low values). 		<p>Clamping for intermittent cut, e.g. interrupted boring, heavy duty milling</p> <ol style="list-style-type: none"> 6. 'Torque' the blocking screw C. 7. 'Torque' screw A (high values). 8. 'Torque' screw B (high values). 9. Double check the blocking screw tightening

Graflex® connection, recommended tightening torques

The Graflex® connection is self locking, therefore it has a low requirement for checking that the locking torques have been applied. There is usually no requirement for torque control. The table shows the recommended torque ranges, prioritising assembly precision (low values) or rigidity/heavy duty (high values).

Graflex size	Recommended Graflex connection tightening torques	
	Ball nose screws (A) & (B) Low values – High values	Tenon blocking screw (C)
G0	1,5 - 2 Nm	-
G1	1,5 - 2 Nm	-
G2	2,5 - 4 Nm	-
G3	5 - 8 Nm	0,4 Nm
G4	13 - 20 Nm	0,7 Nm
G5	17 - 25 Nm	2 Nm
G6	23 - 35 Nm	4 Nm
G7	40 - 60 Nm	8 Nm

Balancing of the Graflex® modules

The balancing quality of each tool holder is shown in its Product page balancing column.

Simplified codes “G2.5”, “G6.3”, “PB” and “-” are used and correspond to:

“G2.5”: Individually balanced at G2,5-25.000 rpm

“G6.3”: Individually balanced at G6,3-20.000 rpm. Can be balanced to G2,5-25.000 on request, please enquire.

“PB”: Pre-balanced by design. Most of the pre-balanced holders can be fine balanced on request, please enquire.

“-”: not balanced

See also the 'Maximum speeds for Graflex® boring heads' Instruction pages.

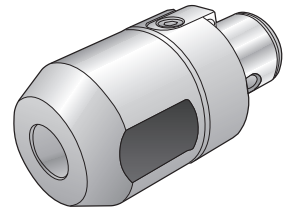

Graflex® connection, Accessories and Spare Parts

Accessories (locking keys) and spare parts (two ball nose screws kits or tenon kits), see product pages.

Graflex® arbors – EPB 401, EPB 409

Graflex® basic arbors are available for all machine spindles type HSK, SA and Seco-Capto™ – Type EM...

HSK-A, DIN, BT, Seco-Capto™ (...) adapters are shown as part of the respective chapters, where tool holders are grouped per machine side connections.

Arbors are mainly available in 3 different lengths (short, medium and long).

Balancing: see Product pages 'Balancing column'.

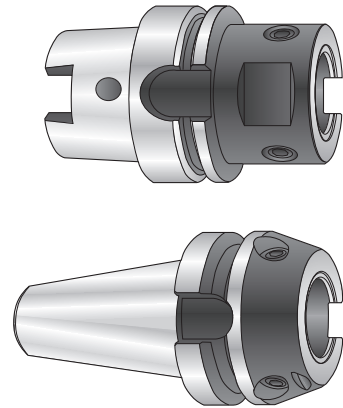

Graflex® adjustable arbors - Type ER...401...

Radial and angular adjustment enable the elimination of run-out of the cutting tool edge (e.g. reamer) in any Graflex® tool holder e.g. hydraulic chuck, Weldon, collet chuck.

Setting:

In order to adjust the cutting tool centre line, 4 screws (1) perform the angular adjustment and 4 screws (2) the radial adjustment. The assembly is locked by 4 screws (3).

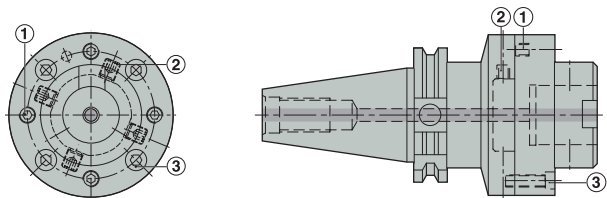

Graflex® flange mounts - Type M409...

Graflex® modules can be securely locked onto the machine spindle, without being influenced by the taper precision and the locking performance of the spindle.

Designed for DIN 2079 spindle.

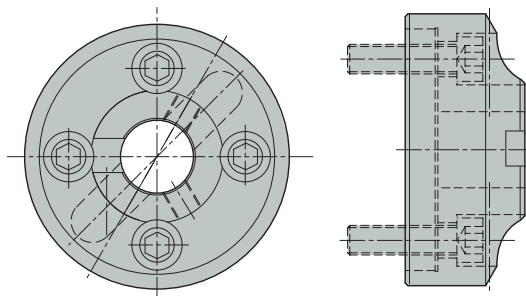

Graflex® extensions – EPB 402

Extensions have the same Graflex® size at the workpiece side (Graflex® bore) and at the machine side (Graflex® shank). They are mainly available in different lengths: short, medium and long.

Extra long extensions are particularly suitable for creating optimum assemblies for Perfomax® modular drill heads SD 600.

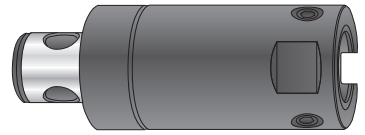

Graflex® reducers – EPB 403

Reducers have a smaller Graflex® size at the workpiece side (Graflex® bore) in relation to the machine side (Graflex® shank).

Long Graflex® reducers

When used with a Graflex® boring head, long Graflex® reducers give boring length to diameter ratio of approx. 4xD.

Extra long Graflex® reducers, carbide type – Type M403...C...

The extension section is manufactured from carbide.
The extra long reducers to be used with fine boring heads for boring length to diameter ratio of approx. 7xD.
Very rigid but brittle extensions, not suitable for heavy duty applications.
Maximum boring lengths are listed in the Product pages (LU).
Other lengths can be supplied on request, please enquire.

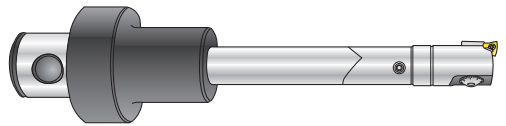
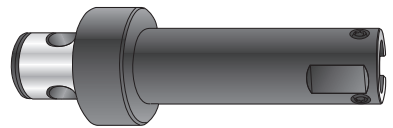
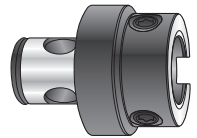

Graflex® enlargers - Part No. M40356 and M40367

The enlargers enable the mounting of modules with large Graflex® connection size 6 or 7 on arbors with maximum connection size 5 or 6.

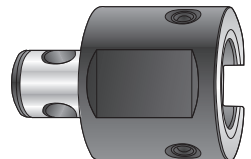

Graflex® cylindrical extensions – EPB 401

Cylindrical Graflex® extensions, steel type

The cylindrical shank, with tolerance h5, can be held in any suitable holding system, including Shrinkfit holders.
 Suitable for long rough or fine boring.
 Maximum boring depths are listed in the Product pages (LU).

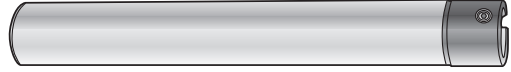

These extensions have a 'through' coolant channel.

Cylindrical Graflex® extensions, carbide type M401...C

Graflex® extensions with cylindrical shank in carbide are suitable for fine boring length to diameter ratios of up to approx. 9xD
 The cylindrical shank with tolerance h5 can be held in Shrinkfit holders, or any other suitable holding system.
 Very rigid but brittle extensions, not suitable for heavy duty applications.
 Maximum boring depths are listed in the Product pages LU).

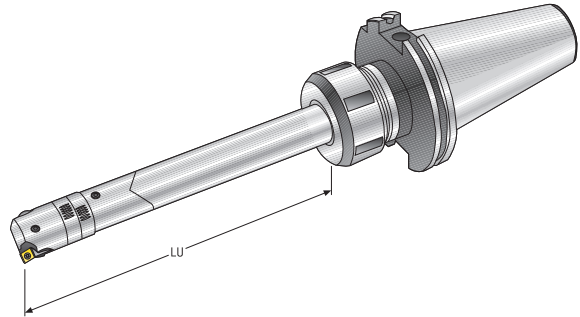

These extensions have a 'through' coolant channel.

Graflex® tool holders – EPB 5525, EPB 584, etc

Graflex® holders are available with main workpiece side types similar to Monobloc holders. Adjustable drill holders are only available with a Graflex® connection for high flexibility.

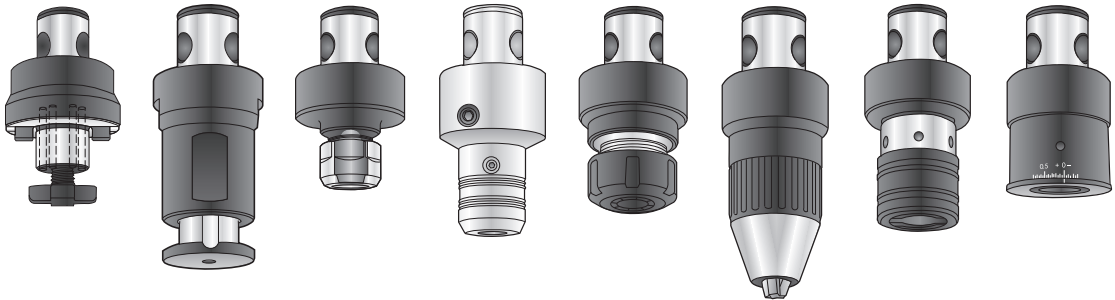

The Seco-Capto™ Tooling range shows:

- **Seco-Capto™ arbors, HSK-A, HSK-E, DIN, BT, DIN2080 (...) adapters are shown as part of the respective chapters, where tool holders are grouped per machine side connections:** Arbors have a non Seco-Capto™ machine side shank (HSK, DIN, BT, ...) and a Seco-Capto™ workpiece side receiver to hold Seco-Capto™ tools, tool holders and intermediates onto rotating or static non PSC* type spindles.
- **Seco-Capto™ Flange Mounts:** Flange Mounts have a machine side flange to be fitted onto SA spindle faces and a Seco-Capto™ workpiece side receiver. For manual clamping of Seco-Capto™ tools, tool holders and intermediates onto rotating or static SA type spindles. Note: Seco-Capto™ Clamping Units to equip turning turrets are part of the Turning catalogue chapter.
- **Seco-Capto™ Intermediates:** Extensions and Reducers, with Seco-Capto™ machine side shank and Seco-Capto™ workpiece side receiver. To extend the length of Seco-Capto™ assemblies or to adapt Seco-Capto™ smaller size items onto larger ones.
- **Seco-Capto™ Tool Holders:** to hold rotary or static tools without PSC* coupling shank (Shell mill, Weldon, Shrinkfit, ...) onto PSC* type spindles or onto Seco-Capto™ Basic Holders, Flanges, Clamping Units and Intermediates. Note: Seco-Capto™ Adapters are the link to the Combimaster (milling) and Graflex® (holders and boring heads) systems.

* PSC stands for Polygonal Shank Coupling, as defined by the Norm ISO26623.

Seco-Capto™ couplings (receivers or shanks) are in accordance with the Norm ISO26623.

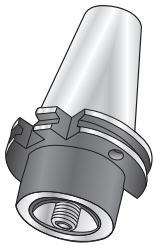

Arbors (and Flanges)

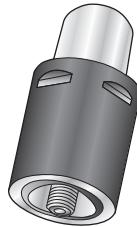

Intermediates

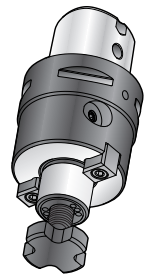

Tool holders (and Adapters)



Instructions and data

Tightening torques for Seco-Capto™ receivers connections with centre bolt clamping (Arbors, Intermediates)

Seco-Capto™ size	Centre bolt tightening torque (Nm)
C3	40-50
C4	50-60
C5	90-100
C6	160-180
C8	160-180

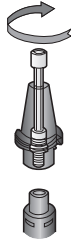

Tightening torques for Seco-Capto™ receivers connections with segment clamping, actuated by cam shaft side locking (Flange Mounts)

Seco-Capto™ size	Cam tightening torque (Nm)
C3	35
C4	50
C5	70
C6	90
C8	130

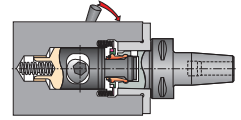

The Seco-Capto™ joint features a self-locking taper. Where the centre bolt system is used, unscrew the centre bolt until the bolt head makes contact with the tool holder, causing the bolt to force the taper joint apart. When using the cam shaft side clamping system, over tightening of the cam will force the taper joint apart.

Balancing

The balancing quality of each tool holder is shown in its Product page balancing column.

Simplified codes “G2.5”, “G6.3”, “PB” and “-” are used and correspond to:

“G2.5”: Individually balanced at G2,5-25.000 rpm

“G6.3”: Individually balanced at G6,3-20.000 rpm. Can be balanced to G2,5-25.000 on request, please enquire.

“PB”: Pre-balanced by design. Most of the pre-balanced holders can be fine balanced on request, please enquire.

“-”: not balanced

Holes for RFID carrier

Product pages contain a column ‘RFID hole’, mentioning if a hole for RFID carrier is available on the tool holders:

RFID hole = 1: the tool holder feature a hole for RFID carrier, according to respective machine side norms. See page(s) 14-24. RFID carriers can be fitted on request, please enquire.

RFID hole = 0: RFID carrier hole not available. Holes for RFID carriers can be machined and RFID carriers fitted on request, please enquire.

Code key, Arbors (and Flange Mounts)

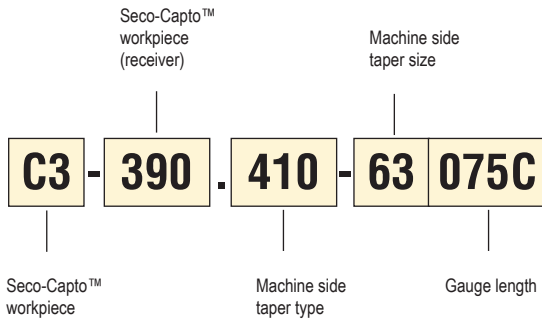

Code key, Intermediates

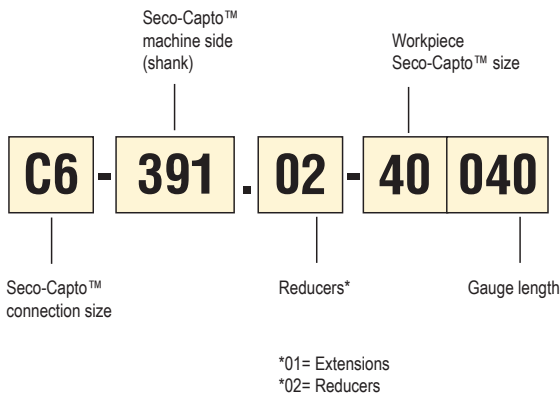

Code key, Tool Holders (and Adapters)

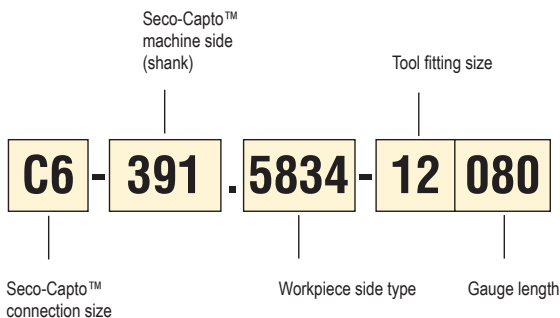

If a Part No. ends with a letter, it is an updated version of the holder, e.g. C4-391.20-12055A (update version A,B,...)

EPB Steadyline® damping holders for turning, boring and threading operations

Steadyline® vibration damping bars for turning, boring and threading operations are available in a variety of body diameters from dia 32 to 100 mm, for 6xD, 8xD and 10xD projections, with cylindrical shanks, HSK-A/T and Seco-Capto™ connections. Seco-Capto™ Steadyline® bars can be mounted on DIN, BT or CAT (including Taper-Face versions) machine spindles using short Seco-Capto™ adapters.

Increase your productivity

Every aspect of Steadyline® holders has been designed with a consideration for increasing productivity, capacity and profitability.

- Patented quick change GL connection: cost and time savings due to quick change system with clamping nut using a fine pitch thread. Polylobe-based connection for centering accuracy and repeatability. Designed for 0°/180° turning head orientation.
- Optimum damping effect through short and compact heads
- Flexibility by using same bars for turning, threading and boring
- Through coolant to improve tool life and chip evacuation

Easy-to-use BA-to-GL adapters, reducing your tool inventory as the same GL50 bars can be used on Steadyline® bars diameter 50, 60 and 80mm

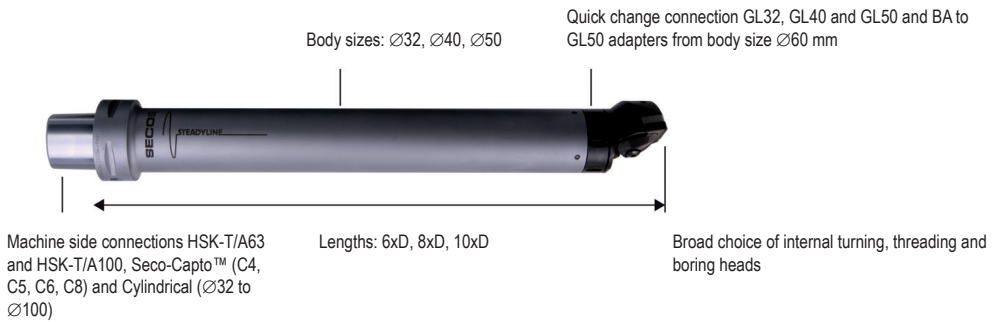

Product range and design:

– Ø32, Ø40 and Ø50 mm: the Steadyline® bars feature the quick change GL workpiece side connection, for GL turning, threading and boring heads (see MN Turning and Holmaking catalogues). The GL connection is available in 3 sizes: GL32, GL40 and GL50.

Recommended tightening torques for GL connection nut

For GL workpiece side size	Recommended tightening torque
GL32	25 Nm
GL40	35 Nm
GL50	55 Nm

To apply the recommended tightening torque, we recommend to use torque spanners, available as Accessories, see Product pages.

– Ø60 and Ø80 mm for turning or threading operations : the Steadyline® bars are built from a Steadyline® holder, with a BA workpiece side connection, a BA to GL adapter and a GL50 turning head.

Steadyline® BA holders with Seco-Capto™ and HSK-T/A machine side connections can also be used for rotating boring operations, when fitted with BA boring heads available. For detailed information about BA to GL adapters, see page(s) 70.

BA connection description:

- To hold adapters BA to GL50, for existing GL50 internal turning heads (see Adapter description below)
- To hold BA rough and fine boring heads
- The BA connection is locked on the side, through 4 Graflex® screws and allow a 0°/180° orientations of adapter vs. holder



Recommended tightening torques for BA connection screws

For BA workpiece side size	Kit of 4 locking screws	Recommended tightening torque
BA060	90FQ4	11 Nm
BA080	90FQ52	16 Nm

We recommend to use HC torque spanners, commonly available on the market.

Machine clamping recommendations

Seco's recommendation for clamping the bars onto the machines is to use bars with Seco-Capto™ machine sides as this solution provides several benefits:

- Maximum stability thanks to the taper-face system and higher bending resistance
- High positioning accuracy of cutting edge

When Seco-Capto™ is not an option, Seco recommends to fit cylindrical bars in a split boring bar holder, inserted at optimum to $4 \times D$.

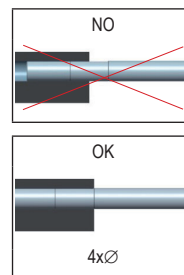

Detailed operating instructions are part of bars delivery content.

Internal turning and threading heads GL: see MN Turning catalogue

Rough and fine boring heads GL: see MN Holmaking catalogue

BA to GL50 Adapters

Adapters allow profitable use of each Steadyline® BA holder with all range of GL50 turning heads, with 2 radial offsets and 0°/180° orientation possibilities.

Machine sides:

- BA060 or BA080 connections

Workpiece sides:

- GL50 connection



BA to GL adapters are designed to hold the wide existing range of GL50 turning heads.

Each BA to GL50 adapter is available in 2 radial offset sizes 'WF' to achieve 2 'f1' reaches:

- First choice: Wide offset WF: GL50 OD wider as bar's OD, recommended, as providing a wider space for chip flow.
- Additional option: Mini offset WF: GL50 OD aligned with bar's OD, when accessibility is limited.

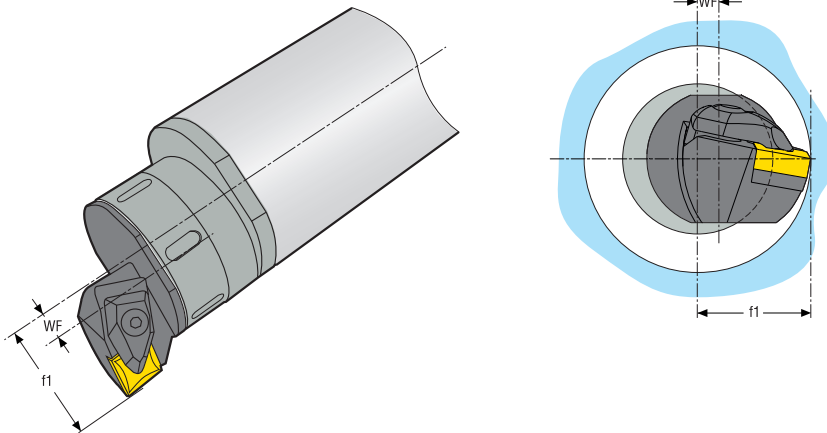

Operating instructions are part of the delivery content of the Steadyline® BA holders, and the BA to GL50 Adapters.

Steadyline bars in automatic tool changers

The maximum swinging torque of heavy, long assemblies must be taken into consideration when an automatic tool changers is used to move the bar in the machine.

The swinging torque for an assembly can be calculated with the following formula. During tool change, the tool acceleration generates an additional force: it is strongly recommended to slow down the tool changing process if the tool weight or torque is close to the machine limits or to change the tool manually.

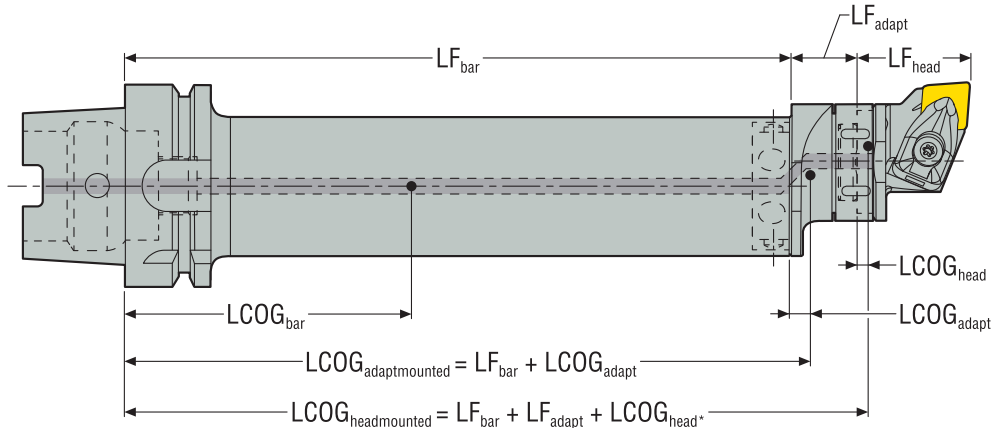

$$T = \frac{g \times (LCOG_{bar} * m_{bar} + LCOG_{adaptmounted} * m_{adapt} + LCOG_{headmounted} * m_{head})}{1000}$$

Where:

T = moment of the assembly in Nm

LF = functional lengths in mm

LCOG = positions of the center of gravity in mm

m = mass in kg.

LCOG, LF and mass values are available in Product pages.

*Note: if LCOG head is unknown, a good estimation can be obtained by replacing LCOG head by ½ LF head

EPB 5555/5556 – Steadyline®, vibration damping shell mill holders

HSK-A/ ISO12164-1-HSK-A



- With dynamic damping, ready to use
- Direct run-out 5 µm maximum
- With coolant supply channels through the spigot

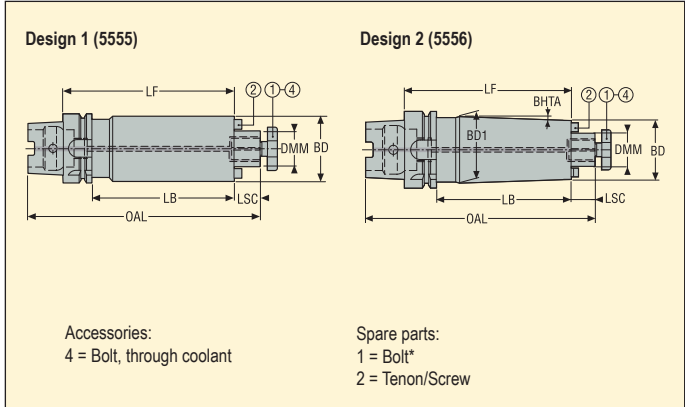

Machine side	Workpiece side	Designation	Dimensions in mm					Design	BHTA*	RFID hole	Balancing	KG	
			LF	BD	BD1	OAL	LB						LSC
HSK-A63	16	E9304555516160	160,0	38,0	38,0	209,0	134,0	17,0	1	–	1	PB	2,40
	22	E9304555522210	210,0	48,0	48,0	261,0	184,0	19,0	1	–	1	PB	3,54
	22	E93045555622260	260,0	48,0	63,3	311,0	234,0	19,0	2	1,9	1	PB	5,38
	27	E9304555527260	260,0	60,0	60,0	313,0	234,0	21,0	1	–	1	PB	6,56
HSK-A100	22	E9306555522210	210,0	48,0	48,0	279,0	181,0	19,0	1	–	1	PB	4,80
	22	E93065555622260	260,0	48,0	65,0	329,0	231,0	19,0	2	1,9	1	PB	6,78
	27	E9306555527260	260,0	60,0	60,0	331,0	231,0	21,0	1	–	1	PB	7,92
	32	E9306555532330	330,0	78,0	78,0	404,0	301,0	24,0	1	–	1	PB	14,42

Accessories

Spare Parts*

For DMM	Bolt, through coolant	Spanner	For DMM	Bolt	Screw	Tenon
16	5801608L	5811608	16	5801608	951D0312	16C2080810A
22	5802210L	5812210	22	5802210	951D0416	16C2101111
27	5802712L	5812712	27	5802712	951D0516	16C2121214A
32	5803216L	5813216	32	5803216	951D0516	16C2141421A

Please check availability in current price and stock-list

* These centre bolts are similar to the original delivered ones: check if lengths are suitable for the milling cutters used, therefore see in the Operating instructions sheet delivered with the holders or in page(s) 30. For HSK sealing plugs, coolant tubes and tube spanners, see page(s) 294

EPB 5525/5524 – Shell mill holders, with through coolant channels

HSK-A/ ISO12164-1-HSK-A



- Direct run-out 5 µm maximum
- With coolant supply channels through the spigot

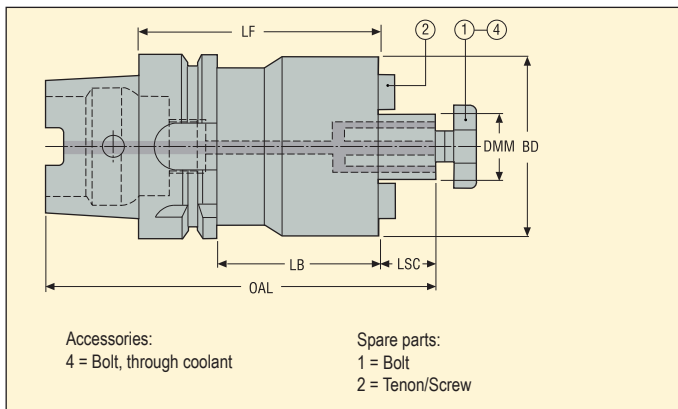

Machine side	Workpiece side	Designation	Dimensions in mm					*	**	RFID hole	Balancing	KG	
			LF	BD	OAL	LB	LSC						
HSK-A63	16	E930455251650	50,0	38,0	99,0	24,0	17,0			1	G6.3	0,88	
	16	E9304552516100	100,0	38,0	149,0	74,0	17,0			1	G6.3	1,31	
	16	E9304552516145	145,0	38,0	194,0	119,0	17,0			1	G6.3	1,70	
	22	E930455252250	50,0	48,0	101,0	24,0	19,0	*		1	G6.3	1,08	
	22	E9304552522100	100,0	48,0	151,0	74,0	19,0			1	G6.3	1,72	
	22	E9304552522160	160,0	48,0	211,0	134,0	19,0			1	G6.3	2,54	
	27	E930455252760	60,0	60,0	113,0	34,0	21,0	*	**	1	G6.3	1,38	
	27	E9304552527100	100,0	60,0	153,0	74,0	21,0			1	G6.3	2,23	
	27	E9304552527160	160,0	60,0	213,0	134,0	21,0			1	G6.3	3,54	
	32	E930455253260	60,0	78,0	116,0	34,0	24,0	*		1	G6.3	1,75	
	32	E9304552532100	100,0	78,0	156,0	74,0	24,0			1	G6.3	2,93	
	40	E930455254060	60,0	89,0	119,0	34,0	27,0	*		1	G6.3	2,02	
		27	E930455242760	60,0	48,0	113,0	34,0	21,0	*	**	1	G6.3	1,20

DMM 40, includes 4 threaded holes on the bearing face according to DIN 6357

** Diameter BD on type 5524 is smaller than on type 5525

* Conform to DIN 69882-3

Accessories

For DMM	Bolt, through coolant	Spanner
16	5801608L	5811608
22	5802210L	5812210
27/5524	5802712L	5812712
27/5525	5802712L	5812712
32	5803216L	5813216
40	5804020L	5814020

Spare Parts

For DMM	Bolt	Screw	Tenon
16	5801608	950D0312	16C10810164
22	5802210	950D0416	16C11012206
27/5524	5802712	951D0512	16C127
27/5525	5802712	951D0516	16C11214243
32	5803216	951D0516	16C2141421
40	5804020	951D0616	16C2161621

Please check availability in current price and stock-list

For HSK sealing plugs, coolant tubes and tube spanners, see page(s) 294

EPB 5525/5524 – Shell mill holders, with through coolant channels

HSK-A/ ISO12164-1-HSK-A



- Direct run-out 5 µm maximum
- With coolant supply channels through the spigot

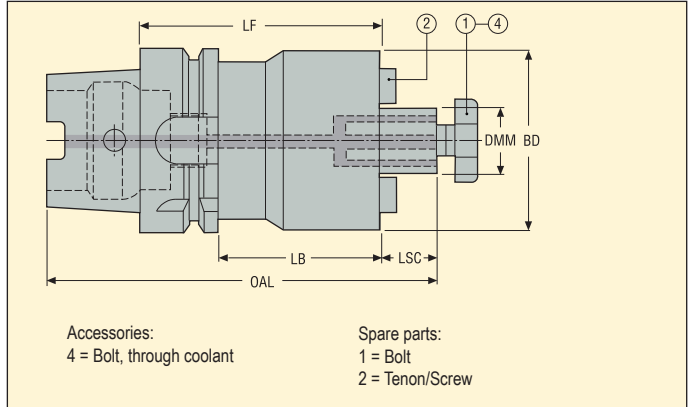

Machine side	Workpiece side	Designation	Dimensions in mm					*	**	RFID hole	Balancing	KG	
			LF	BD	OAL	LB	LSC						
HSK-A100	16	E9306552516100	100,0	38,0	167,0	71,0	17,0			1	G6.3	1,36	
	22	E930655252250	50,0	48,0	119,0	21,0	19,0	*		1	G6.3	2,35	
	22	E9306552522100	100,0	48,0	169,0	71,0	19,0			1	G6.3	3,00	
	22	E9306552522160	160,0	48,0	229,0	131,0	19,0			1	G6.3	3,90	
	27	E930655252750	50,0	60,0	121,0	21,0	21,0	*	**	1	G6.3	2,53	
	27	E9306552527100	100,0	60,0	171,0	71,0	21,0			1	G6.3	3,60	
	27	E9306552527160	160,0	60,0	231,0	131,0	21,0			1	G6.3	4,87	
	32	E930655253250	50,0	78,0	124,0	21,0	24,0	*		1	G6.3	2,96	
	32	E9306552532100	100,0	78,0	174,0	71,0	24,0			1	G6.3	4,78	
	32	E9306552532160	160,0	78,0	234,0	131,0	24,0			1	G6.3	6,98	
	40	E930655254060	60,0	89,0	137,0	31,0	27,0	*		1	G6.3	3,64	
	40	E9306552540100	100,0	89,0	177,0	71,0	27,0			1	G6.3	5,56	
	40	E9306552540160	160,0	89,0	237,0	131,0	27,0			1	G6.3	8,41	
		27	E930655242750	50,0	48,0	121,0	21,0	21,0		**	1	G6.3	2,36

DMM 40, includes 4 threaded holes on the bearing face according to DIN 6357

* Conform to DIN 69882-3

** Diameter BD on type 5524 is smaller than on type 5525

Accessories

Spare Parts

For DMM	Bolt, through coolant	Spanner	For DMM	Bolt	Screw	Tenon
16	5801608L	5811608	16	5801608	950D0312	16C10810164
22	5802210L	5812210	22	5802210	950D0416	16C11012206
27/5524	5802712L	5812712	27/5524	5802712	951D0512	16C127
27/5525	5802712L	5812712	27/5525	5802712	951D0516	16C11214243
32	5803216L	5813216	32	5803216	951D0516	16C2141421
40	5804020L	5814020	40	5804020	951D0616	16C2161621

Please check availability in current price and stock-list

For HSK sealing plugs, coolant tubes and tube spanners, see page(s) 294

EPB 569 – Milling cutter holders, flange mounting – DIN 6357/ DIN 2079

HSK-A/ ISO12164-1-HSK-A



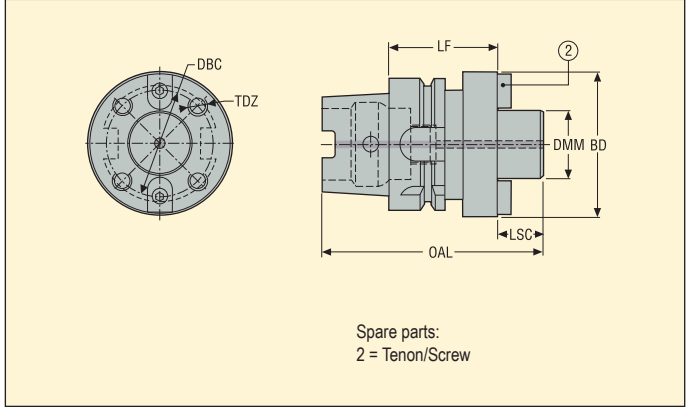

- Direct run-out 5 µm maximum

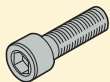

Machine side	Workpiece side	Designation	Dimensions in mm					TDZ	RFID hole	Balancing	KG
			LF	BD	OAL	LSC	DBC				
Taper	DMM mm										
HSK-A100	60	E93065696075	75,0	129,0	165,0	40,0	101,6	M16	1	G6.3	6,80

Spare Parts

For DMM	Screw	Tenon
		
60	951D1225	16C35060

Please check availability in current price and stock-list
For HSK sealing plugs, coolant tubes and tube spanners, see page(s) 294

EPB 5657 – Disc mill holders

HSK-A/ ISO12164-1-HSK-A



- With adjustable slide rod
- Best suitable for Seco disc mill cutters Type A

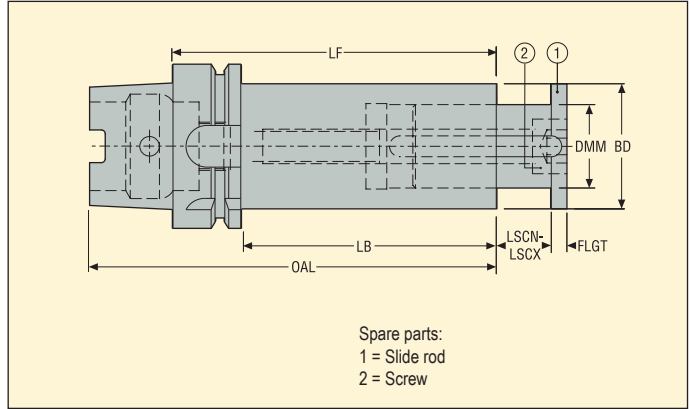

Machine side	Workpiece side	Designation	Dimensions in mm						RFID hole	Balancing	KG
			LF	BD	OAL	LB	LSCN-LSCX	FLGT			
HSK-A63	22	E930456572290	90,0	35,0	122,0	64,0	0,0-12,0	4,0	1	PB	1,13
	27	E9304565727120	120,0	42,0	152,0	94,0	0,0-15,0	5,0	1	PB	1,66
	32	E9304565732150	150,0	48,0	182,0	124,0	0,0-24,0	6,0	1	PB	2,39
HSK-A100	40	E9306565740190	190,0	58,0	240,0	161,0	0,0-30,0	7,0	1	PB	5,30
	50	E9306565750235	235,0	72,0	285,0	206,0	0,0-32,0	8,0	1	PB	8,44

Spare Parts

For DMM	Screw	Slide rod
22	19C565722	565722
27	19C565727	565727
32	950D1690	565732
40	19C565740	565740
50	19C565750	565750

Please check availability in current price and stock-list
For HSK sealing plugs, coolant tubes and tube spanners, see page(s) 294



- Direct run-out 3 µm maximum
- Weldon \varnothing DCBN-DCBX 16, 20, 25, 32 and 40 with ground face (Seco-Weldon compatible)

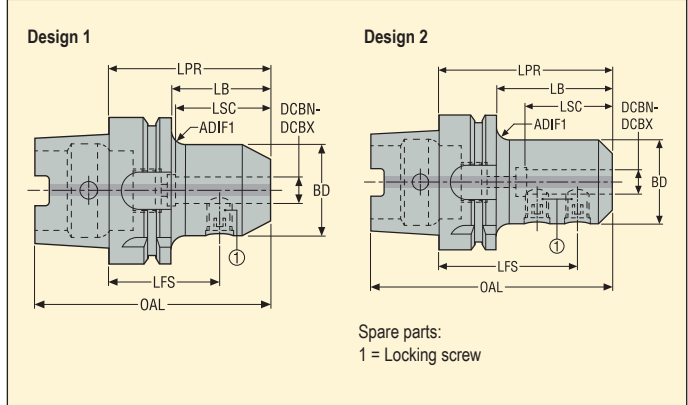

Machine side	Workpiece side	Designation	Dimensions in mm						*	ADIF1	Design	RFID hole	Balancing	KG
			DCBN-DCBX mm	LPR	LB	LSC	BD	OAL						
HSK-A63	6	E93045840665	65,0	39,0	27,0	25,0	97,0	47,5	*	3	1	1	G6.3	0,85
	8	E93045840865	65,0	39,0	30,0	28,0	97,0	47,5	*	3	1	1	G6.3	0,80
	8	E930458408120	120,0	94,0	30,0	28,0	152,0	102,5		3	1	1	G6.3	1,10
	10	E93045841065	65,0	39,0	36,0	35,0	97,0	45,5	*	3	1	1	G6.3	0,90
	10	E930458410120	120,0	94,0	36,0	35,0	152,0	100,5		3	1	1	G6.3	1,30
	12	E93045841280	80,0	54,0	43,0	42,0	112,0	58,0	*	3	1	1	G6.3	1,15
	12	E930458412120	120,0	94,0	43,0	42,0	152,0	98,0		3	1	1	G6.3	1,55
	14	E93045841480	80,0	54,0	43,0	44,0	112,0	58,0	*	3	1	1	G6.3	1,20
	16	E93045841680	80,0	54,0	46,0	48,0	112,0	56,5	*	3	1	1	G6.3	1,25
	16	E930458416120	120,0	94,0	46,0	48,0	152,0	96,5		2.5	1	1	G6.3	1,85
	18	E93045841880	80,0	54,0	46,0	50,0	112,0	56,5	*	1.5	1	1	G6.3	1,35
	20	E93045842080	80,0	54,0	48,0	52,0	112,0	55,5	*	0.8	1	1	G6.3	1,35
	20	E930458420120	120,0	94,0	48,0	52,0	152,0	95,5		0.8	1	1	G6.3	2,00
	25	E930458425110	110,0	68,0	54,0	63,0	142,0	86,5	*	–	2	1	G6.3	2,25
	32	E930458432110	110,0	84,0	58,0	72,0	142,0	86,5	*	–	2	1	G6.3	2,55

Balancing G6.3, with steel shank

* Conform to DIN 69882-4

Spare Parts

For DCBN-DCBX	Locking screw
6	951C0610
8	951C0810
10	951C1012
12-14	951C1216
16-18	951C1416
20	951C1616
25	951C1820
32	951C2020

Please check availability in current price and stock-list

For HSK sealing plugs, coolant tubes and tube spanners, see page(s) 294

EPB 584 – Side lock holders, Weldon – DIN 1835 Form B/ DIN 6535 Form HB

HSK-A/ ISO12164-1-HSK-A



- Direct run-out 3 µm maximum
- Weldon ØDCBN-DCBX 16, 20, 25, 32 and 40 with ground face (Seco-Weldon compatible)

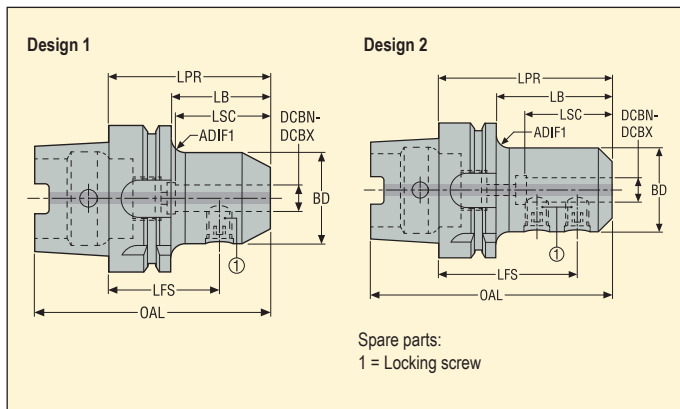

Machine side	Workpiece side	Designation	Dimensions in mm						*	ADIF1	Design	RFID hole	Balancing	KG
			LPR	LB	LSC	BD	OAL	LFS						
HSK-A100	6	E93065840680	80,0	51,0	27,0	25,0	130,0	62,5	*	15	1	1	PB	2,20
	8	E93065840880	80,0	51,0	30,0	28,0	130,0	62,5	*	10	1	1	PB	2,25
	10	E93065841080	80,0	51,0	36,0	35,0	130,0	60,5	*	5	1	1	PB	2,35
	12	E93065841280	80,0	51,0	43,0	42,0	130,0	58,0	*	5	1	1	PB	2,45
	16	E930658416100	100,0	71,0	46,0	48,0	150,0	76,5	*	5	1	1	PB	2,85
	16	E930658416160	160,0	131,0	46,0	48,0	210,0	136,5		5	1	1	PB	3,65
	20	E930658420100	100,0	71,0	48,0	52,0	150,0	75,0	*	5	1	1	PB	3,00
	20	E930658420160	160,0	131,0	48,0	52,0	210,0	135,5		5	1	1	PB	3,95
	25	E930658425100	100,0	71,0	54,0	65,0	150,0	76,5	*	5	2	1	PB	3,50
	25	E930658425160	160,0	131,0	54,0	65,0	210,0	136,5		5	2	1	PB	5,00
	32	E930658432100	100,0	71,0	58,0	72,0	150,0	76,5	*	5	2	1	PB	3,80
	32	E930658432160	160,0	131,0	58,0	72,0	210,0	136,5		5	2	1	PB	5,60
	40	E930658440120	120,0	91,0	68,0	80,0	170,0	90,5		5	2	1	PB	4,70
	50	E930658450130	130,0	101,0	78,0	100,0	180,0	95,0		–	2	1	PB	6,24

Balancing G6.3, with steel shank

* Conform to DIN 69882-4

Spare Parts

For DCBN-DCBX	Locking screw
6	951C0610
8	951C0810
10	951C1012
12-14	951C1216
16-18	951C1416
20	951C1616
25	951C1820
32-40	951C2020
50	951C2425

Please check availability in current price and stock-list

For HSK sealing plugs, coolant tubes and tube spanners, see page(s) 294

EPB 5603/5403 – Shrinkfit holders, DIN type – DIN 69882-8

HSK-A/ ISO12164-1-HSK-A

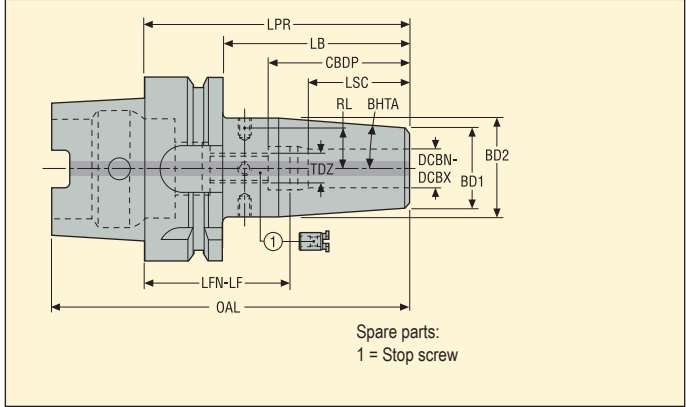

- Run-out 3 µm maximum at 3 x ∅DCBN-DCBX
- Delivered with one stop screw

Machine side	Workpiece side	DCBN-DCBX mm	Designation	Dimensions in mm								TDZ	BHTA°	RL mm	*	RFID hole	Balancing	KG
				LPR	LB	CBDP	LSC	BD2	BD1	OAL	LFN-LF							
HSK-A40	6	E930256030680	80,0	60,0	37,5	22,0	27,0	21,0	100,0	44,0-58,0	M5x0.8	4,5	10,5	*	0	G2.5	0,40	
	8	E930256030880	80,0	60,0	37,5	26,0	27,0	21,0	100,0	44,0-54,0	M6x1	4,5	10,5	*	0	G2.5	0,40	
	10	E930256031080	80,0	60,0	42,5	31,0	32,0	24,0	100,0	39,0-49,0	M8x1	4,5	13,0	*	0	G2.5	0,45	
	12	E930256031290	90,0	70,0	47,5	34,0	32,0	24,0	110,0	44,0-56,0	M10x1	4,5	13,0	*	0	G2.5	0,49	
	16	E930256031690	90,0	70,0	50,5	39,0	34,0	27,0	110,0	41,0-51,0	M12x1	4,5	14,0	*	0	G2.5	0,51	
HSK-A63	6	E930454030680	80,0	54,0	37,5	22,0	27,0	21,0	112,0	44,0-58,0	M5x0.8	4,5	10,5	*	1	G2.5	0,90	
	6	E9304540306120	120,0	94,0	37,5	22,0	27,0	21,0	152,0	84,0-98,0	M5x0.8	4,5	10,5		1	G2.5	1,00	
	6	E9304540306160	160,0	134,0	37,5	22,0	27,0	21,0	192,0	124,0-138,0	M5x0.8	4,5	10,5		1	G2.5	1,20	
	8	E930454030880	80,0	54,0	38,0	26,0	27,0	21,0	112,0	43,5-54,0	M6x1	4,5	10,5	*	1	G2.5	0,90	
	8	E9304540308120	120,0	94,0	38,0	26,0	27,0	21,0	152,0	83,5-94,0	M6x1	4,5	10,5		1	G2.5	1,00	
	8	E9304540308160	160,0	134,0	38,0	26,0	27,0	21,0	192,0	123,5-134,0	M6x1	4,5	10,5		1	G2.5	1,20	
	10	E930454031085	85,0	59,0	43,5	31,0	32,0	24,0	117,0	43,0-54,0	M8x1	4,5	13,0	*	1	G2.5	0,90	
	10	E9304540310120	120,0	94,0	43,5	31,0	32,0	24,0	152,0	78,0-89,0	M8x1	4,5	13,0		1	G2.5	1,20	
	10	E9304540310160	160,0	134,0	43,5	31,0	32,0	24,0	192,0	118,0-129,0	M8x1	4,5	13,0		1	G2.5	1,30	
	12	E930454031290	90,0	64,0	48,0	34,0	32,0	24,0	122,0	43,5-56,0	M10x1	4,5	13,0	*	1	G2.5	0,90	
	12	E9304540312120	120,0	94,0	48,0	34,0	32,0	24,0	152,0	73,5-86,0	M10x1	4,5	13,0		1	G2.5	1,10	
	12	E9304540312160	160,0	134,0	48,0	34,0	32,0	24,0	192,0	113,5-126,0	M10x1	4,5	13,0		1	G2.5	1,40	
	14	E930454031490	90,0	64,0	49,0	34,0	34,0	27,0	122,0	42,5-56,0	M10x1	4,5	14,0	*	1	G2.5	1,00	
	14	E9304540314120	120,0	94,0	49,0	34,0	34,0	27,0	152,0	72,5-86,0	M10x1	4,5	14,0		1	G2.5	1,20	

For Shrinkfit extensions, see page(s) 221

* Conform to DIN 69882-8

Accessories

For DCBN-DCBX	Balancing screws
6	90ZQ01
8	90ZQ01
10	90ZQ01
12-14	90ZQ01
16	90ZQ01

Spare Parts

For DCBN-DCBX	Stop screw
6	19BDR05165
8	19BDR06165
10	19BDR08165
12-14	19BDR10165
16	19BDR12165

Please check availability in current price and stock-list

For HSK sealing plugs, coolant tubes and tube spanners, see page(s) 294

EPB 5603/5403 – Shrinkfit holders, DIN type – DIN 69882-8

HSK-A/ ISO12164-1-HSK-A



- Run-out 3 μm maximum at 3 x ∅DCBN-DCBX
- Delivered with one stop screw

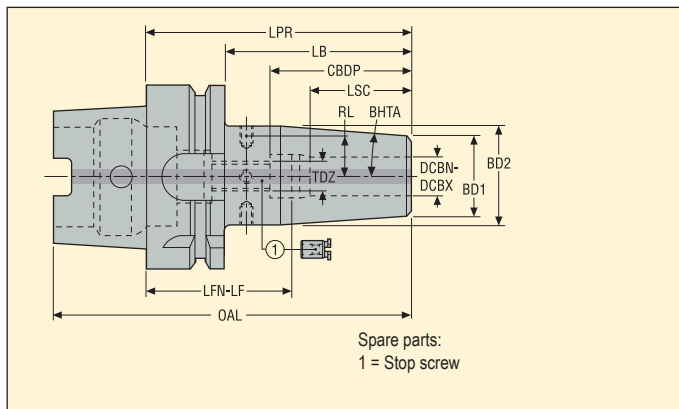

Machine side	Workpiece side	Designation	Dimensions in mm								TDZ	BHTA°	RL mm	*	RFID hole	Balancing	KG
			LPR	LB	CBDP	LSC	BD2	BD1	OAL	LFN-LF							
HSK-A63	16	E930454031695	95,0	69,0	52,5	39,0	34,0	27,0	127,0	45,0-56,0	M12x1	4,5	14,0	*	1	G2.5	1,00
	16	E9304540316120	120,0	94,0	52,5	39,0	34,0	27,0	152,0	71,0-81,0	M12x1	4,5	14,0		1	G2.5	1,20
	16	E9304540316160	160,0	134,0	52,5	39,0	34,0	27,0	192,0	111,0-121,0	M12x1	4,5	14,0		1	G2.5	1,40
	18	E930454031895	95,0	69,0	53,0	39,0	42,0	33,0	127,0	44,5-56,0	M12x1	4,5	18,0	*	1	G2.5	1,20
	18	E9304540318120	120,0	94,0	53,0	39,0	42,0	33,0	152,0	71,0-81,0	M12x1	4,5	18,0		1	G2.5	1,40
	20	E9304540320100	100,0	74,0	55,5	41,0	42,0	33,0	132,0	47,5-59,0	M16x1	4,5	18,0	*	1	G2.5	1,20
	20	E9304540320120	120,0	94,0	55,5	41,0	42,0	33,0	152,0	67,5-79,0	M16x1	4,5	18,0		1	G2.5	1,40
	20	E9304540320160	160,0	134,0	55,5	41,0	42,0	33,0	192,0	107,5-119,0	M16x1	4,5	18,0		1	G2.5	1,80
	25	E9304540325115	115,0	89,0	63,5	47,0	53,0	44,0	147,0	58,0-68,0	M16x1	4,5	23,5	*	1	G2.5	1,80
	25	E9304540325160	160,0	134,0	63,5	47,0	53,0	44,0	192,0	103,0-113,0	M16x1	4,5	23,5		1	G2.5	2,60
	32	E9304540332120	120,0	94,0	70,0	51,0	53,0	44,0	152,0	56,5-69,0	M16x1	4,5	23,5	*	1	G2.5	1,70

For Shrinkfit extensions, see page(s) 221

* Conform to DIN 69882-8

Accessories

For DCBN-DCBX/ LPR	Balancing screws
16 /95	90ZQ01
16 /120	90ZQ01
16 /160	90ZQ01
18 /95	90ZQ01
18 /120	90ZQ01
20	90ZQ01
25-32	90ZQ01

Spare Parts

For DCBN-DCBX/ LPR	Stop screw
16 /95	19BDR12165
16 /120	19BDR12195
16 /160	19BDR12195
18 /95	19BDR12165
18 /120	19BDR12195
20	19BDR16190
25-32	19BDR16225

Please check availability in current price and stock-list

For HSK sealing plugs, coolant tubes and tube spanners, see page(s) 294

EPB 5603/5403 – Shrinkfit holders, DIN type – DIN 69882-8

HSK-A/ ISO12164-1-HSK-A



- Run-out 3 µm maximum at 3 x ∅DCBN-DCBX
- Delivered with one stop screw

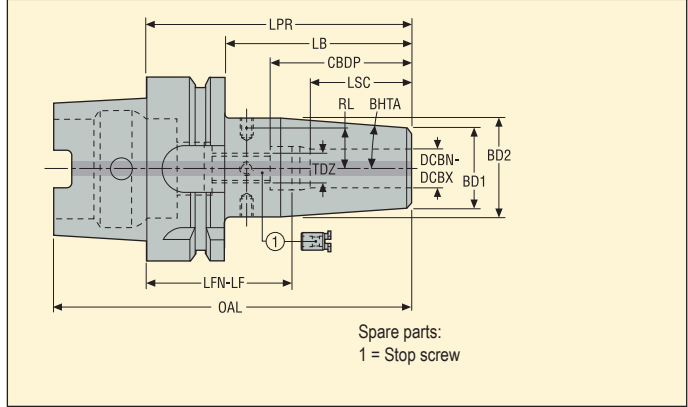

Machine side	Workpiece side	Designation	Dimensions in mm								TDZ	BHTA°	RL mm	*	RFID hole	Balancing	KG
			LPR	LB	CBDP	LSC	BD2	BD1	OAL	LFN-LF							
HSK-A100	6	E930654030685	85,0	56,0	37,5	22,0	27,0	21,0	135,0	49,0-63,0	M5x0.8	4,5	10,5	*	1	G2.5	2,20
	6	E9306540306120	120,0	91,0	37,5	22,0	27,0	21,0	170,0	84,0-98,0	M5x0.8	4,5	10,5		1	G2.5	2,40
	6	E9306540306160	160,0	131,0	37,5	22,0	27,0	21,0	210,0	124,0-138,0	M5x0.8	4,5	10,5		1	G2.5	2,50
	8	E930654030885	85,0	56,0	38,0	26,0	27,0	21,0	135,0	48,5-59,0	M6x1	4,5	10,5	*	1	G2.5	2,20
	8	E9306540308120	120,0	91,0	38,0	26,0	27,0	21,0	170,0	83,5-94,0	M6x1	4,5	10,5		1	G2.5	2,30
	8	E9306540308160	160,0	131,0	38,0	26,0	27,0	21,0	210,0	123,5-134,0	M6x1	4,5	10,5		1	G2.5	2,50
	10	E930654031090	90,0	61,0	43,5	31,0	32,0	24,0	140,0	48,0-59,0	M8x1	4,5	13,0	*	1	G2.5	2,30
	10	E9306540310120	120,0	91,0	43,5	31,0	32,0	24,0	170,0	78,0-89,0	M8x1	4,5	13,0		1	G2.5	2,50
	10	E9306540310160	160,0	131,0	43,5	31,0	32,0	24,0	210,0	118,0-129,0	M8x1	4,5	13,0		1	G2.5	2,70
	12	E930654031295	95,0	66,0	48,0	34,0	32,0	24,0	145,0	48,5-61,0	M10x1	4,5	13,0	*	1	G2.5	2,30
	12	E9306540312120	120,0	91,0	48,0	34,0	32,0	24,0	170,0	73,5-86,0	M10x1	4,5	13,0		1	G2.5	2,40
	12	E9306540312160	160,0	131,0	48,0	34,0	32,0	24,0	210,0	113,5-126,0	M10x1	4,5	13,0		1	G2.5	2,70
	14	E930654031495	95,0	66,0	49,0	34,0	34,0	27,0	145,0	47,5-61,0	M10x1	4,5	14,0	*	1	G2.5	2,30
	16	E9306540316100	100,0	71,0	52,5	39,0	34,0	27,0	150,0	50,0-61,0	M12x1	4,5	14,0	*	1	G2.5	2,30
	16	E9306540316130	130,0	101,0	52,5	39,0	34,0	27,0	180,0	78,0-91,0	M12x1	4,5	14,0		1	G2.5	2,50
	16	E9306540316160	160,0	131,0	52,5	39,0	34,0	27,0	210,0	108,0-121,0	M12x1	4,5	14,0		1	G2.5	2,70
	18	E9306540318100	100,0	71,0	53,0	39,0	42,0	33,0	150,0	52,5-61,0	M12x1	4,5	18,0	*	1	G2.5	2,50

For Shrinkfit extensions, see page(s) 221

* Conform to DIN 69882-8

Accessories

For DCBN-DCBX/ LPR	Balancing screws
6	90ZQ01
8	90ZQ01
10	90ZQ01
12-14	90ZQ01
16/ 100	90ZQ01
16/ 130	90ZQ01
16/ 160	90ZQ01
18	90ZQ01

Spare Parts

For DCBN-DCBX/ LPR	Stop screw
6	19BDR05165
8	19BDR06165
10	19BDR08165
12-14	19BDR10165
16/ 100	19BDR12165
16/ 130	19BDR12195
16/ 160	19BDR12195
18	19BDR12165

Please check availability in current price and stock-list

For HSK sealing plugs, coolant tubes and tube spanners, see page(s) 294

EPB 5403M – Shrinkfit holders, DIN type – DIN 69090-3

HSK-A/ ISO12164-1-HSK-A

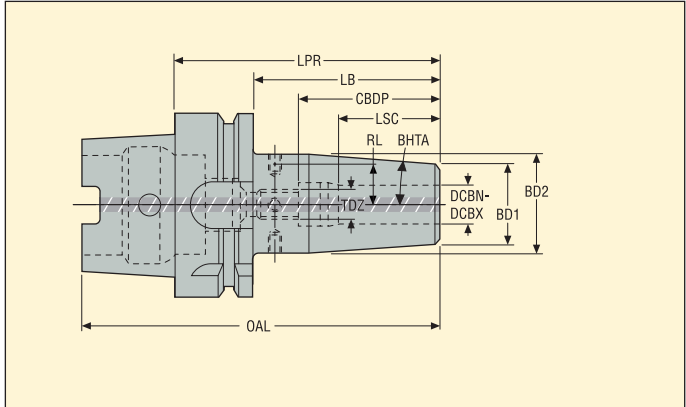

- Run-out 3 µm maximum at 3 x ∅DCBN-DCBX
- Designed for MQL1 and MQL2, accessories to be ordered separately

Machine side	Workpiece side	Designation	Dimensions in mm							TDZ	BHTA°	RL mm	*	RFID hole	Balancing	KG
			LPR	LB	CBDP	LSC	BD2	BD1	OAL							
HSK-A63	6	E930454030680M	80,0	54,0	37,5	22,0	27,0	21,0	112,0	M5x0.8	4,5	10,5	*	1	G2.5	0,90
	6	E9304540306120M	120,0	94,0	37,5	22,0	27,0	21,0	152,0	M5x0.8	4,5	10,5	*	1	G2.5	1,10
	6	E9304540306160M	160,0	134,0	37,5	22,0	27,0	21,0	192,0	M5x0.8	4,5	10,5	*	1	G2.5	1,20
	8	E930454030880M	80,0	54,0	38,0	26,0	27,0	21,0	112,0	M6x1	4,5	10,5	*	1	G2.5	0,90
	8	E9304540308120M	120,0	94,0	38,0	26,0	27,0	21,0	152,0	M6x1	4,5	10,5	*	1	G2.5	1,00
	8	E9304540308160M	160,0	134,0	38,0	26,0	27,0	21,0	192,0	M6x1	4,5	10,5	*	1	G2.5	1,20
	10	E930454031085M	85,0	59,0	43,5	31,0	32,0	24,0	117,0	M8x1	4,5	13,0	*	1	G2.5	0,90
	10	E9304540310120M	120,0	94,0	43,5	31,0	32,0	24,0	152,0	M8x1	4,5	13,0	*	1	G2.5	1,20
	10	E9304540310160M	160,0	134,0	43,5	31,0	32,0	24,0	192,0	M8x1	4,5	13,0	*	1	G2.5	1,40
	12	E930454031290M	90,0	64,0	48,0	34,0	32,0	24,0	122,0	M10x1	4,5	13,0	*	1	G2.5	1,00
	12	E9304540312120M	120,0	94,0	48,0	34,0	32,0	24,0	152,0	M10x1	4,5	13,0	*	1	G2.5	1,10
	12	E9304540312160M	160,0	134,0	48,0	34,0	32,0	24,0	192,0	M10x1	4,5	13,0	*	1	G2.5	1,40
	14	E930454031490M	90,0	64,0	49,0	34,0	34,0	27,0	122,0	M10x1	4,5	14,0	*	1	G2.5	1,00
	14	E9304540314120M	120,0	94,0	49,0	34,0	34,0	27,0	152,0	M10x1	4,5	14,0	*	1	G2.5	1,20
	16	E930454031695M	95,0	69,0	52,5	39,0	34,0	27,0	127,0	M10x1	4,5	14,0	*	1	G2.5	1,00
	16	E9304540316120M	120,0	94,0	52,5	39,0	34,0	27,0	152,0	M10x1	4,5	14,0	*	1	G2.5	1,20
	16	E9304540316160M	160,0	134,0	52,5	39,0	34,0	27,0	192,0	M10x1	4,5	14,0	*	1	G2.5	1,50
	18	E930454031895M	95,0	69,0	53,0	39,0	42,0	33,0	127,0	M10x1	4,5	18,0	*	1	G2.5	1,20
	18	E9304540318120M	120,0	94,0	53,0	39,0	42,0	33,0	152,0	M10x1	4,5	18,0	*	1	G2.5	1,50
	20	E9304540320100M	100,0	74,0	55,5	41,0	42,0	33,0	132,0	M10x1	4,5	18,0	*	1	G2.5	1,20
	20	E9304540320120M	120,0	94,0	55,5	41,0	42,0	33,0	152,0	M10x1	4,5	18,0	*	1	G2.5	1,40
	20	E9304540320160M	160,0	134,0	55,5	41,0	42,0	33,0	192,0	M10x1	4,5	18,0	*	1	G2.5	1,80
	25	E9304540325115M	115,0	89,0	63,5	47,0	53,0	44,0	147,0	M10x1	4,5	23,5	*	1	G2.5	1,80
	25	E9304540325160M	160,0	134,0	63,5	47,0	53,0	44,0	192,0	M10x1	4,5	23,5	*	1	G2.5	2,50
	32	E9304540332120M	120,0	94,0	70,0	51,0	53,0	44,0	152,0	M10x1	4,5	23,5	*	1	G2.5	1,70

* Conform to DIN 69090-3

Accessories

For DCBN-DCBX	Balancing screws
6-32	90ZQ01

Please check availability in current price and stock-list

For MQL1 coolant tubes and stop screws, see page(s) 295-296

For MQL2 coolant tubes and stop screws, see page(s) 297-299

EPB 5403M – Shrinkfit holders, DIN type – DIN 69090-3

HSK-A/ ISO12164-1-HSK-A



- Run-out 3 μm maximum at 3 x ØDCBN-DCBX
- Designed for MQL1 and MQL2, accessories to be ordered separately

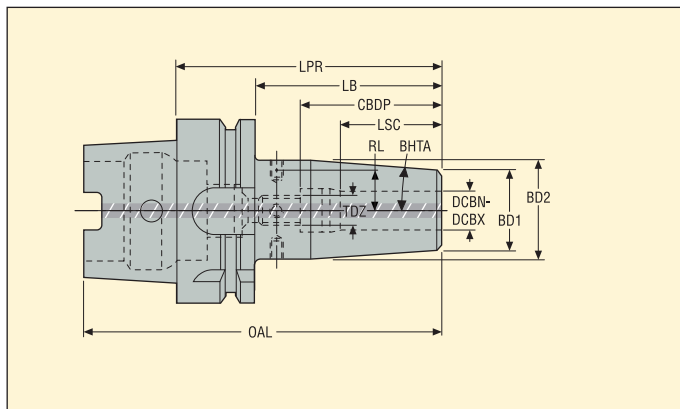

Machine side	Workpiece side	Designation	Dimensions in mm							TDZ	BHTA°	RL mm	*	RFID hole	Balancing	KG
			LPR	LB	CBDP	LSC	BD2	BD1	OAL							
HSK-A100	6	E930654030685M	85,0	56,0	37,5	22,0	27,0	21,0	135,0	M5x0,8	4,5	10,5	*	1	G2.5	2,20
	6	E9306540306120M	120,0	91,0	37,5	22,0	27,0	21,0	170,0	M5x0,8	4,5	10,5	*	1	G2.5	2,40
	6	E9306540306160M	160,0	131,0	37,5	22,0	27,0	21,0	210,0	M5x0,8	4,5	10,5	*	1	G2.5	2,60
	8	E930654030885M	85,0	56,0	38,0	26,0	27,0	21,0	135,0	M6x1	4,5	10,5	*	1	G2.5	2,20
	8	E9306540308120M	120,0	91,0	38,0	26,0	27,0	21,0	170,0	M6x1	4,5	10,5	*	1	G2.5	2,40
	8	E9306540308160M	160,0	131,0	38,0	26,0	27,0	21,0	210,0	M6x1	4,5	10,5	*	1	G2.5	2,60
	10	E930654031090M	90,0	61,0	43,5	31,0	32,0	24,0	140,0	M8x1	4,5	13,0	*	1	G2.5	2,30
	10	E9306540310120M	120,0	91,0	43,5	31,0	32,0	24,0	170,0	M8x1	4,5	13,0	*	1	G2.5	2,50
	10	E9306540310160M	160,0	131,0	43,5	31,0	32,0	24,0	210,0	M8x1	4,5	13,0	*	1	G2.5	2,70
	12	E930654031295M	95,0	66,0	48,0	34,0	32,0	24,0	145,0	M10x1	4,5	13,0	*	1	G2.5	2,30
	12	E9306540312120M	120,0	91,0	48,0	34,0	32,0	24,0	170,0	M10x1	4,5	13,0	*	1	G2.5	2,50
	12	E9306540312160M	160,0	131,0	48,0	34,0	32,0	24,0	210,0	M10x1	4,5	13,0	*	1	G2.5	2,70
	14	E930654031495M	95,0	66,0	49,0	34,0	34,0	27,0	145,0	M10x1	4,5	14,0	*	1	G2.5	2,40
	16	E9306540316100M	100,0	71,0	52,5	39,0	34,0	27,0	150,0	M10x1	4,5	14,0	*	1	G2.5	2,40
	16	E9306540316130M	130,0	101,0	52,5	39,0	34,0	27,0	180,0	M10x1	4,5	14,0	*	1	G2.5	2,60
	16	E9306540316160M	160,0	131,0	52,5	39,0	34,0	27,0	210,0	M10x1	4,5	14,0	*	1	G2.5	2,80
	18	E9306540318100M	100,0	71,0	53,0	39,0	42,0	33,0	150,0	M10x1	4,5	18,0	*	1	G2.5	2,60
	20	E9306540320105M	105,0	76,0	55,5	41,0	42,0	33,0	155,0	M10x1	4,5	18,0	*	1	G2.5	2,60
	20	E9306540320130M	130,0	101,0	55,5	41,0	42,0	33,0	180,0	M10x1	4,5	18,0	*	1	G2.5	2,80
	20	E9306540320160M	160,0	131,0	55,5	41,0	42,0	33,0	210,0	M10x1	4,5	18,0	*	1	G2.5	3,20
	25	E9306540325115M	115,0	86,0	63,5	47,0	53,0	44,0	165,0	M10x1	4,5	23,5	*	1	G2.5	3,10
	25	E9306540325160M	160,0	131,0	63,5	47,0	53,0	44,0	210,0	M10x1	4,5	23,5	*	1	G2.5	3,90
	32	E9306540332120M	120,0	91,0	70,0	51,0	53,0	44,0	170,0	M10x1	4,5	23,5	*	1	G2.5	3,10

* Conform to DIN 69090-3

Accessories

For DCBN-DCBX	Balancing screws
6-32	90ZQ01

Please check availability in current price and stock-list

For MQL1 coolant tubes and stop screws, see page(s) 295-296

For MQL2 coolant tubes and stop screws, see page(s) 297-299

EPB 5403M2 – Shrinkfit holders MQL2

HSK-A/ ISO12164-1-HSK-A



- Run-out 3 µm maximum at 3 x ∅DCBN-DCBX
- Delivered ready for MQL2 with stop screw and coolant tube fitted

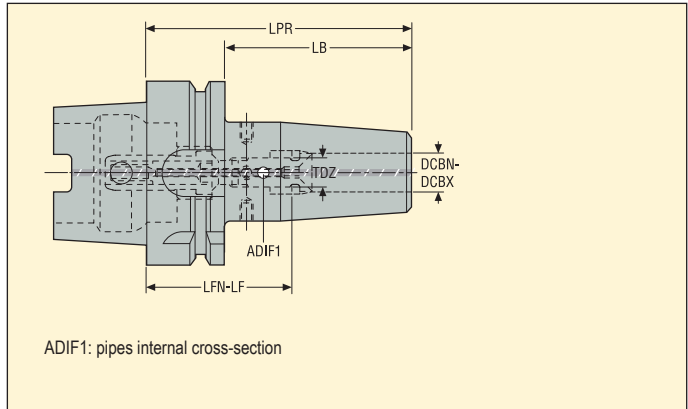

Machine side	Workpiece side	ADIF1 mm ²	Designation	Spare Parts			Dimensions in mm				TDZ	KG
				Tool holders	Coolant tube MQL2	Stop screw MQL2	LPR	LB	LFN-LF			
HSK-A63	6	2.01	E930454030680M2-1.9	E930454030680M	20E9304M2A02	19MQL2A01	80,0	54,0	44,0-54,0	M5x0.8	0,90	
	6	4.15	E930454030680M2-2.8	E930454030680M	20E9304M2B02	19MQL2B01	80,0	54,0	44,0-54,0	M5x0.8	0,90	
	6	2.01	E9304540306120M2-1.9	E9304540306120M	20E9304M2A06	19MQL2A01	120,0	94,0	84,0-94,0	M5x0.8	1,10	
	6	4.15	E9304540306120M2-2.8	E9304540306120M	20E9304M2B09	19MQL2B01	120,0	94,0	84,0-94,0	M5x0.8	1,10	
	6	2.01	E9304540306160M2-1.9	E9304540306160M	20E9304M2A10	19MQL2A01	160,0	134,0	124,0-134,0	M5x0.8	1,30	
	6	4.15	E9304540306160M2-2.8	E9304540306160M	20E9304M2B16	19MQL2B01	160,0	134,0	124,0-134,0	M5x0.8	1,30	
	8	2.01	E930454030880M2-1.9	E930454030880M	20E9304M2A02	19MQL2A02	80,0	54,0	44,0-54,0	M6x1	0,90	
	8	4.15	E930454030880M2-2.8	E930454030880M	20E9304M2B02	19MQL2B02	80,0	54,0	44,0-54,0	M6x1	0,90	
	8	2.01	E9304540308120M2-1.9	E9304540308120M	20E9304M2A06	19MQL2A02	120,0	94,0	84,0-94,0	M6x1	1,10	
	8	4.15	E9304540308120M2-2.8	E9304540308120M	20E9304M2B09	19MQL2B02	120,0	94,0	84,0-94,0	M6x1	1,10	
	8	2.01	E9304540308160M2-1.9	E9304540308160M	20E9304M2A10	19MQL2A02	160,0	134,0	124,0-134,0	M6x1	1,30	
	8	4.15	E9304540308160M2-2.8	E9304540308160M	20E9304M2B16	19MQL2B02	160,0	134,0	124,0-134,0	M6x1	1,30	
	10	2.01	E930454031085M2-1.9	E930454031085M	20E9304M2A02	19MQL2A03	85,0	59,0	44,0-54,0	M8x1	1,00	
	10	4.15	E930454031085M2-2.8	E930454031085M	20E9304M2B02	19MQL2B03	85,0	59,0	44,0-54,0	M8x1	1,00	
	10	2.01	E9304540310120M2-1.9	E9304540310120M	20E9304M2A05	19MQL2A03	120,0	94,0	79,0-89,0	M8x1	1,20	
	10	4.15	E9304540310120M2-2.8	E9304540310120M	20E9304M2B08	19MQL2B03	120,0	94,0	79,0-89,0	M8x1	1,20	
	10	2.01	E9304540310160M2-1.9	E9304540310160M	20E9304M2A09	19MQL2A03	160,0	134,0	119,0-129,0	M8x1	1,40	
	10	4.15	E9304540310160M2-2.8	E9304540310160M	20E9304M2B15	19MQL2B03	160,0	134,0	119,0-129,0	M8x1	1,40	
	12	2.01	E930454031290M2-1.9	E930454031290M	20E9304M2A01	19MQL2A04	90,0	64,0	44,0-54,0	M10x1	1,00	
	12	4.15	E930454031290M2-2.8	E930454031290M	20E9304M2B01	19MQL2B04	90,0	64,0	44,0-54,0	M10x1	1,00	
	12	9.08	E930454031290M2-4.0	E930454031290M	20E9304M2C01	19MQL2C01	90,0	64,0	44,0-54,0	M10x1	1,00	
	12	2.01	E9304540312120M2-1.9	E9304540312120M	20E9304M2A04	19MQL2A04	120,0	94,0	74,0-84,0	M10x1	1,20	
	12	4.15	E9304540312120M2-2.8	E9304540312120M	20E9304M2B07	19MQL2B04	120,0	94,0	74,0-84,0	M10x1	1,20	
	12	9.08	E9304540312120M2-4.0	E9304540312120M	20E9304M2C06	19MQL2C01	120,0	94,0	74,0-84,0	M10x1	1,20	
	12	2.01	E9304540312160M2-1.9	E9304540312160M	20E9304M2A08	19MQL2A04	160,0	134,0	114,0-124,0	M10x1	1,40	
	12	4.15	E9304540312160M2-2.8	E9304540312160M	20E9304M2B14	19MQL2B04	160,0	134,0	114,0-124,0	M10x1	1,40	
	12	9.08	E9304540312160M2-4.0	E9304540312160M	20E9304M2C11	19MQL2C01	160,0	134,0	114,0-124,0	M10x1	1,40	
	14	2.01	E930454031490M2-1.9	E930454031490M	20E9304M2A01	19MQL2A05	90,0	64,0	44,0-54,0	M10x1	1,10	
	14	4.15	E930454031490M2-2.8	E930454031490M	20E9304M2B01	19MQL2B05	90,0	64,0	44,0-54,0	M10x1	1,10	
	14	9.08	E930454031490M2-4.0	E930454031490M	20E9304M2C01	19MQL2C02	90,0	64,0	44,0-54,0	M10x1	1,10	
14	2.01	E9304540314120M2-1.9	E9304540314120M	20E9304M2A04	19MQL2A05	120,0	94,0	74,0-84,0	M10x1	1,30		
14	4.15	E9304540314120M2-2.8	E9304540314120M	20E9304M2B07	19MQL2B05	120,0	94,0	74,0-84,0	M10x1	1,30		
14	9.08	E9304540314120M2-4.0	E9304540314120M	20E9304M2C06	19MQL2C02	120,0	94,0	74,0-84,0	M10x1	1,30		
16	2.01	E930454031695M2-1.9	E930454031695M	20E9304M2A01	19MQL2A06	95,0	69,0	46,0-56,0	M10x1	1,10		
16	4.15	E930454031695M2-2.8	E930454031695M	20E9304M2B01	19MQL2B06	95,0	69,0	46,0-56,0	M10x1	1,10		
16	9.08	E930454031695M2-4.0	E930454031695M	20E9304M2C01	19MQL2C03	95,0	69,0	46,0-56,0	M10x1	1,10		
16	2.01	E9304540316120M2-1.9	E9304540316120M	20E9304M2A03	19MQL2A06	120,0	94,0	71,0-81,0	M10x1	1,20		
16	4.15	E9304540316120M2-2.8	E9304540316120M	20E9304M2B06	19MQL2B06	120,0	94,0	71,0-81,0	M10x1	1,20		
16	9.08	E9304540316120M2-4.0	E9304540316120M	20E9304M2C05	19MQL2C03	120,0	94,0	71,0-81,0	M10x1	1,20		
16	2.01	E9304540316160M2-1.9	E9304540316160M	20E9304M2A07	19MQL2A06	160,0	134,0	111,0-121,0	M10x1	1,50		
16	4.15	E9304540316160M2-2.8	E9304540316160M	20E9304M2B13	19MQL2B06	160,0	134,0	111,0-121,0	M10x1	1,50		
16	9.08	E9304540316160M2-4.0	E9304540316160M	20E9304M2C10	19MQL2C03	160,0	134,0	111,0-121,0	M10x1	1,50		

Please check availability in current price and stock-list
For details about MQL2 accessories, see page(s) 297-299

EPB 5403M2 – Shrinkfit holders MQL2

HSK-A/ ISO12164-1-HSK-A



- Run-out 3 µm maximum at 3 x ∅DCBN-DCBX
- Delivered ready for MQL2 with stop screw and coolant tube fitted

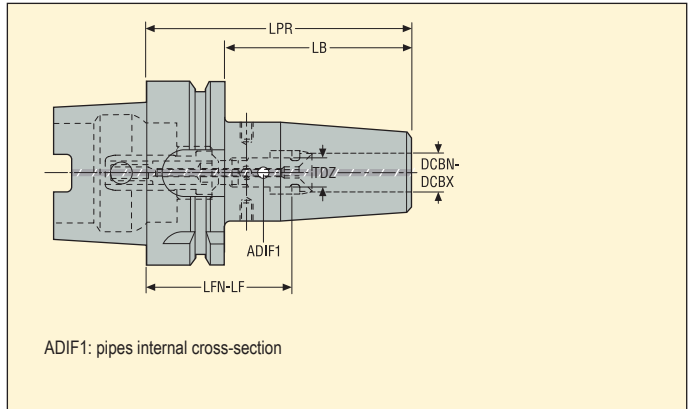

Machine side	Workpiece side	ADIF1 mm ²	Designation	Spare Parts			Dimensions in mm				TDZ	KG
				Tool holders	Coolant tube MQL2	Stop screw MQL2	LPR	LB	LFN-LF			
HSK-A100	6	2.01	E930654030685M2-1.9	E930654030685M	20E9306M2A02	19MQL2A01	85,0	56,0	49,0-59,0	M5x0.8	2,30	
	6	4.15	E930654030685M2-2.8	E930654030685M	20E9306M2B02	19MQL2B01	85,0	56,0	49,0-59,0	M5x0.8	2,30	
	6	2.01	E9306540306120M2-1.9	E9306540306120M	20E9306M2A05	19MQL2A01	120,0	91,0	84,0-94,0	M5x0.8	2,50	
	6	4.15	E9306540306120M2-2.8	E9306540306120M	20E9306M2B06	19MQL2B01	120,0	91,0	84,0-94,0	M5x0.8	2,50	
	6	2.01	E9306540306160M2-1.9	E9306540306160M	20E9306M2A09	19MQL2A01	160,0	131,0	124,0-134,0	M5x0.8	2,70	
	6	4.15	E9306540306160M2-2.8	E9306540306160M	20E9306M2B12	19MQL2B01	160,0	131,0	124,0-134,0	M5x0.8	2,70	
	8	2.01	E930654030885M2-1.9	E930654030885M	20E9306M2A02	19MQL2A02	85,0	56,0	49,0-59,0	M6x1	2,30	
	8	4.15	E930654030885M2-2.8	E930654030885M	20E9306M2B02	19MQL2B02	85,0	56,0	49,0-59,0	M6x1	2,30	
	8	2.01	E9306540308120M2-1.9	E9306540308120M	20E9306M2A05	19MQL2A02	120,0	91,0	84,0-94,0	M6x1	2,50	
	8	4.15	E9306540308120M2-2.8	E9306540308120M	20E9306M2B06	19MQL2B02	120,0	91,0	84,0-94,0	M6x1	2,50	
	8	2.01	E9306540308160M2-1.9	E9306540308160M	20E9306M2A09	19MQL2A02	160,0	131,0	124,0-134,0	M6x1	2,60	
	8	4.15	E9306540308160M2-2.8	E9306540308160M	20E9306M2B12	19MQL2B02	160,0	131,0	124,0-134,0	M6x1	2,60	
	10	2.01	E930654031090M2-1.9	E930654031090M	20E9306M2A02	19MQL2A03	90,0	61,0	49,0-59,0	M8x1	2,40	
	10	4.15	E930654031090M2-2.8	E930654031090M	20E9306M2B02	19MQL2B03	90,0	61,0	49,0-59,0	M8x1	2,40	
	10	2.01	E9306540310120M2-1.9	E9306540310120M	20E9306M2A04	19MQL2A03	120,0	91,0	79,0-89,0	M8x1	2,60	
	10	4.15	E9306540310120M2-2.8	E9306540310120M	20E9306M2B04	19MQL2B03	120,0	91,0	79,0-89,0	M8x1	2,60	
	10	2.01	E9306540310160M2-1.9	E9306540310160M	20E9306M2A08	19MQL2A03	160,0	131,0	119,0-129,0	M8x1	2,80	
	10	4.15	E9306540310160M2-2.8	E9306540310160M	20E9306M2B11	19MQL2B03	160,0	131,0	119,0-129,0	M8x1	2,80	
	12	2.01	E930654031295M2-1.9	E930654031295M	20E9306M2A01	19MQL2A04	95,0	66,0	49,0-59,0	M10x1	2,40	
	12	4.15	E930654031295M2-2.8	E930654031295M	20E9306M2B01	19MQL2B04	95,0	66,0	49,0-59,0	M10x1	2,40	
	12	9.08	E930654031295M2-4.0	E930654031295M	20E9306M2C01	19MQL2C01	95,0	66,0	49,0-59,0	M10x1	2,40	
	12	2.01	E9306540312120M2-1.9	E9306540312120M	20E9306M2A03	19MQL2A04	120,0	91,0	74,0-84,0	M10x1	2,60	
	12	4.15	E9306540312120M2-2.8	E9306540312120M	20E9306M2B03	19MQL2B04	120,0	91,0	74,0-84,0	M10x1	2,60	
	12	9.08	E9306540312120M2-4.0	E9306540312120M	20E9306M2C02	19MQL2C01	120,0	91,0	74,0-84,0	M10x1	2,60	
	12	2.01	E9306540312160M2-1.9	E9306540312160M	20E9306M2A07	19MQL2A04	160,0	131,0	114,0-124,0	M10x1	2,80	
	12	4.15	E9306540312160M2-2.8	E9306540312160M	20E9306M2B10	19MQL2B04	160,0	131,0	114,0-124,0	M10x1	2,80	
	12	9.08	E9306540312160M2-4.0	E9306540312160M	20E9306M2C08	19MQL2C01	160,0	131,0	114,0-124,0	M10x1	2,80	
	14	2.01	E930654031495M2-1.9	E930654031495M	20E9306M2A01	19MQL2A05	95,0	66,0	49,0-59,0	M10x1	2,50	
14	4.15	E930654031495M2-2.8	E930654031495M	20E9306M2B01	19MQL2B05	95,0	66,0	49,0-59,0	M10x1	2,50		
14	9.08	E930654031495M2-4.0	E930654031495M	20E9306M2C01	19MQL2C02	95,0	66,0	49,0-59,0	M10x1	2,50		
16	2.01	E9306540316100M2-1.9	E9306540316100M	20E9306M2A01	19MQL2A06	100,0	71,0	51,0-61,0	M10x1	2,50		
16	4.15	E9306540316100M2-2.8	E9306540316100M	20E9306M2B01	19MQL2B06	100,0	71,0	51,0-61,0	M10x1	2,50		
16	9.08	E9306540316100M2-4.0	E9306540316100M	20E9306M2C01	19MQL2C03	100,0	71,0	51,0-61,0	M10x1	2,50		
16	2.01	E9306540316130M2-1.9	E9306540316130M	20E9306M2A04	19MQL2A06	130,0	101,0	81,0-91,0	M10x1	2,70		
16	4.15	E9306540316130M2-2.8	E9306540316130M	20E9306M2B04	19MQL2B06	130,0	101,0	81,0-91,0	M10x1	2,70		
16	9.08	E9306540316130M2-4.0	E9306540316130M	20E9306M2C03	19MQL2C03	130,0	101,0	81,0-91,0	M10x1	2,70		
16	2.01	E9306540316160M2-1.9	E9306540316160M	20E9306M2A06	19MQL2A06	160,0	131,0	111,0-121,0	M10x1	2,90		
16	4.15	E9306540316160M2-2.8	E9306540316160M	20E9306M2B09	19MQL2B06	160,0	131,0	111,0-121,0	M10x1	2,90		
16	9.08	E9306540316160M2-4.0	E9306540316160M	20E9306M2C07	19MQL2C03	160,0	131,0	111,0-121,0	M10x1	2,90		

Please check availability in current price and stock-list
For details about MQL2 accessories, see page(s) 297-299

EPB 5600 – Shrinkfit holders, reinforced

HSK-A/ ISO12164-1-HSK-A



- Reinforced design with wider front and tapered body
- Run-out maximum: 3 µm at 3 x ØDCBN-DCBX and 3 µm direct
- With coolant supply channels towards the tool (plugged)
- Delivered with one stop screw

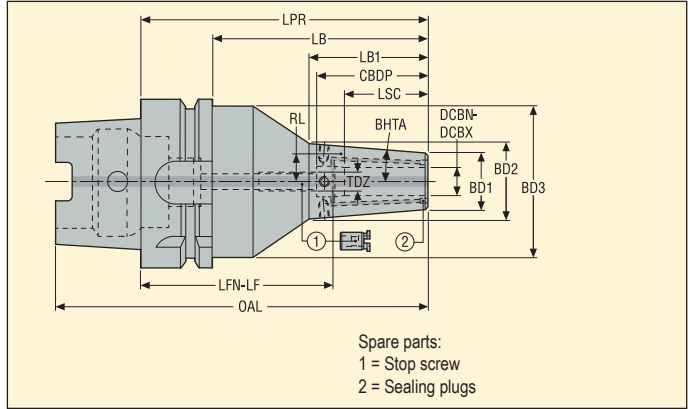

Machine side	Workpiece side	DCBN-DCBX mm	Designation	Dimensions in mm										TDZ	BHTA°	**	RL mm	***	RFID hole	Balancing	KG
				LPR*	LB	LB1	CBDP	LSC	BD3	BD2	BD1	OAL	LFN-LF								
HSK-A63	6	E93045600670	70,0	44,0	44,0	37,5	22,0	—	32,2	24,0	102,0	34,0-48,0	M5x0,8	4,5	**	12,0		1	G2.5	0,85	
	6	E930456006130	130,0	104,0	52,0	37,5	22,0	52,5	32,2	24,0	162,0	94,0-108,0	M5	4,5	12,0		1	G2.5	1,55		
	6	E930456006160	160,0	134,0	52,0	37,5	22,0	52,5	32,2	24,0	192,0	124,0-138,0	M5	4,5	12,0		1	G2.5	1,90		
	8	E93045600870	70,0	44,0	44,0	37,5	26,0	—	32,2	24,0	102,0	34,0-44,0	M6x1	4,5	**	12,0		1	G2.5	0,85	
	8	E930456008130	130,0	104,0	52,0	37,5	26,0	52,5	32,2	24,0	162,0	94,0-104,0	M6	4,5	12,0		1	G2.5	1,55		
	10	E930456001070	70,0	44,0	44,0	42,5	31,0	—	35,2	27,0	102,0	29,0-39,0	M8x1	4,5	**	13,5		1	G2.5	0,85	
	10	E9304560010130	130,0	104,0	52,0	42,5	31,0	52,5	35,2	27,0	162,0	89,0-99,0	M8x1	4,5	13,5		1	G2.5	1,60		
	10	E9304560010160	160,0	134,0	52,0	42,5	31,0	52,5	35,2	27,0	192,0	119,0-129,0	M8x1	4,5	13,5		1	G2.5	1,95		
	12	E930456001270	70,0	44,0	44,0	46,0	34,0	—	35,2	27,0	102,0	24,0-36,0	M10x1	4,5	**	13,5		1	G2.5	0,85	
	12	E9304560012130	130,0	104,0	52,0	47,5	34,0	52,5	35,2	27,0	162,0	84,0-96,0	M10x1	4,5	13,5		1	G2.5	1,60		
	12	E9304560012160	160,0	134,0	52,0	47,5	34,0	52,5	35,2	27,0	192,0	114,0-126,0	M10x1	4,5	13,5		1	G2.5	1,95		
	16	E930456001675	75,0	49,0	49,0	50,5	39,0	—	42,1	33,0	107,0	26,0-36,0	M12x1	4,5	**	17,0		1	G2.5	1,00	
	16	E9304560016130	130,0	104,0	58,0	50,5	39,0	52,5	42,1	33,0	162,0	81,0-91,0	M12x1	4,5	17,0		1	G2.5	1,70		
	20	E930456002075	75,0	49,0	49,0	50,5	41,0	—	53,1	44,0	107,0	24,0-34,0	M16x1	4,5	**	21,5		1	G2.5	1,19	
	20	E9304560020130	130,0	104,0	58,0	52,5	41,0	52,5	53,1	44,0	162,0	79,0-89,0	M16x1	4,5	21,5		1	G2.5	2,12		
25	E930456002585	85,0	59,0	59,0	58,5	47,0	52,5	57,1	48,0	117,0	28,0-38,0	M16x1	4,5	**	25,0	***	1	G2.5	1,41		
32	E930456003285	85,0	59,0	59,0	61,0	51,0	52,5	57,1	48,0	117,0	24,0-34,0	M16x1	4,5	**	25,0	***	1	G2.5	1,25		

* If LPR = 70, 75 or 85: Extra-short holders requiring a dedicated Easyshrink® cooling contact bush type "5600 extra short", see page(s) 339

** Holder without thread for a stop screw, *** Holder without threaded holes for balancing screw

Accessories

For DCBN-DCBX	Balancing screws
6	90ZQ01
8	90ZQ01
10	90ZQ01
12	90ZQ01
16	90ZQ01
20-32	90ZQ01

Spare Parts

For DCBN-DCBX	Sealing plugs	Stop screw
6	90AI03	19BDR05165
8	90AI03	19BDR06165
10	90AI03	19BDR08165
12	90AI03	19BDR10165
16	90AI03	19BDR12165
20-32	90AI04	19BDR16165

Please check availability in current price and stock-list

For HSK sealing plugs, coolant tubes and tube spanners, see page(s) 294

EPB 5600 – Shrinkfit holders, reinforced

HSK-A/ ISO12164-1-HSK-A



- Reinforced design with wider front and tapered body
- Run-out maximum: 3 μm at 3 x ØDCBN-DCBX and 3 μm direct
- With coolant supply channels towards the tool (plugged)
- Delivered with one stop screw

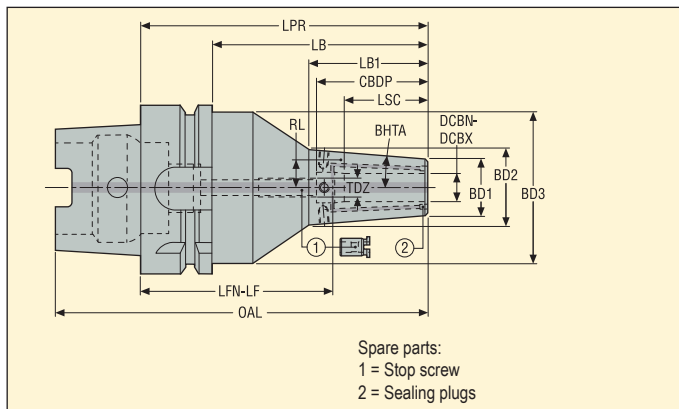

Machine side	Workpiece side	DCBN-DCBX mm	Designation	Dimensions in mm										TDZ	BHTA°	RL mm	RFID hole	Balancing	KG
				LPR	LB	LB1	CBDP	LSC	BD3	BD2	BD1	OAL	LFN-LF						
HSK-A100	6	E9306560006160	160,0	131,0	52,0	37,5	22,0	87,5	32,2	24,0	210,0	124,0-138,0	M5	4,5	12,0	1	G2,5	4,45	
	8	E9306560008160	160,0	131,0	52,0	37,5	26,0	87,5	32,2	24,0	210,0	124,0-134,0	M6	4,5	12,0	1	G2,5	4,45	
	10	E930656001090	90,0	61,0	61,0	42,5	31,0	—	35,2	27,0	140,0	49,0-59,0	M8x1	4,5	13,5	1	G2,5	2,35	
	10	E9306560010160	160,0	131,0	52,0	42,5	31,0	87,5	35,2	27,0	210,0	119,0-129,0	M8x1	4,5	13,5	1	G2,5	4,55	
	12	E930656001295	95,0	66,0	66,0	47,5	34,0	—	35,2	27,0	145,0	49,0-61,0	M10x1	4,5	13,5	1	G2,5	2,40	
	12	E9306560012160	160,0	131,0	58,0	47,5	34,0	87,5	35,2	27,0	210,0	114,0-126,0	M10x1	4,5	13,5	1	G2,5	4,50	
	16	E9306560016100	100,0	71,0	71,0	50,5	39,0	—	42,1	33,0	150,0	51,0-61,0	M12x1	4,5	17,0	1	G2,5	2,55	
	16	E9306560016160	160,0	131,0	58,0	50,5	39,0	87,5	53,1	33,0	210,0	111,0-121,0	M12x1	4,5	17,0	1	G2,5	4,65	
	16	E9306560016200	200,0	171,0	58,0	50,5	39,0	87,5	42,1	33,0	250,0	151,0-161,0	M12x1	4,5	17,0	1	G2,5	5,70	
	20	E9306560020105	105,0	76,0	76,0	52,5	41,0	—	53,1	44,0	155,0	54,0-64,0	M16x1	4,5	21,5	1	G2,5	3,01	
	20	E9306560020160	160,0	131,0	131,0	52,5	41,0	87,5	53,1	44,0	210,0	109,0-119,0	M16x1	4,5	21,5	1	G2,5	5,12	
	20	E9306560020200	200,0	171,0	171,0	52,5	41,0	87,5	53,1	44,0	250,0	149,0-159,0	M16x1	4,5	21,5	1	G2,5	6,32	
	25	E9306560025115	115,0	86,0	86,0	58,5	47,0	87,5	57,1	48,0	165,0	58,0-68,0	M16x1	4,5	25,0	1	G2,5	3,93	
	25	E9306560025160	160,0	131,0	161,0	58,5	47,0	87,5	57,1	48,0	210,0	103,0-113,0	M16x1	4,5	25,0	1	G2,5	5,37	
	25	E9306560025200	200,0	171,0	58,0	58,5	47,0	87,5	57,1	48,0	250,0	143,0-153,0	M16x1	4,5	25,0	1	G2,5	6,67	
	32	E9306560032115	115,0	86,0	86,0	62,5	51,0	87,5	57,1	48,0	165,0	54,0-64,0	M16x1	4,5	25,0	1	G2,5	3,75	
32	E9306560032160	160,0	131,0	58,0	62,5	51,0	87,5	57,1	48,0	210,0	99,0-109,0	M16x1	4,5	25,0	1	G2,5	5,20		

Accessories

For DCBN-DCBX	Balancing screws
6	90ZQ01
8	90ZQ01
10	90ZQ01
12	90ZQ01
16	90ZQ01
20-32	90ZQ01

Spare Parts

For DCBN-DCBX	Sealing plugs	Stop screw
6	90AI03	19BDR05165
8	90AI03	19BDR06165
10	90AI03	19BDR08165
12	90AI03	19BDR10165
16	90AI03	19BDR12165
20-32	90AI04	19BDR16165

Please check availability in current price and stock-list

For HSK sealing plugs, coolant tubes and tube spanners, see page(s) 294

EPB 5600P Safe-Lock™ – Shrinkfit holders, reinforced and with tool pull-out protection

HSK-A/ ISO12164-1-HSK-A

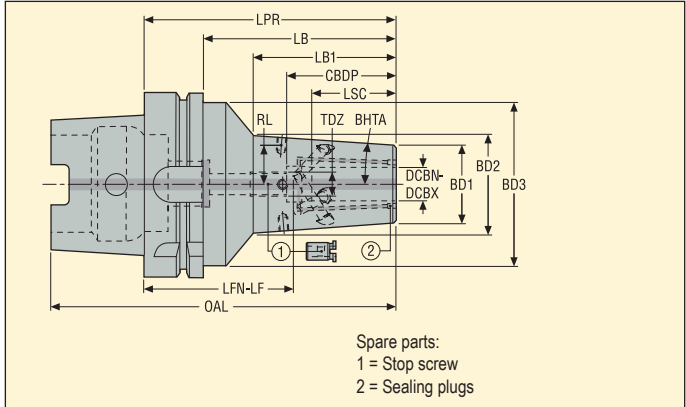

- With Safe-Lock™ tool pull-out protection system
- Reinforced design of EPB 5600
- Run-out maximum: 3 μm at 3 x ∅DCBN-DCBX and 3 μm direct
- With coolant supply channels towards the tool (plugged)
- Delivered with one stop screw fitted

Machine side	Workpiece side	DCBN-DCBX mm	Designation	Dimensions in mm										TDZ	BHTA°	**	RL mm	***	RFID hole	Balancing	KG
				LPR*	LB	LB1	CBDP	LSC	BD3	BD2	BD1	OAL	LFN-LF								
HSK-A63	12	E930456001270P	70,0	44,0	–	46,0	34,0	–	33,9	27,0	102,0	–	–	4,5	**	13,5	1	G2.5	0,85		
	16	E930456001675P	75,0	49,0	–	50,5	39,0	–	40,8	33,0	107,0	–	–	4,5	**	17,0	1	G2.5	1,00		
	20	E930456002075P	75,0	49,0	–	50,5	41,0	–	51,7	44,0	107,0	–	–	4,5	**	21,5	1	G2.5	1,19		
	25	E930456002585P	85,0	59,0	–	58,5	47,0	–	56,5	48,0	117,0	–	–	4,5	**	–	***	1	G2.5	1,41	
HSK-A100	12	E930656001295P	95,0	66,0	66,0	47,5	34,0	–	37,4	27,0	145,0	49,0-57,5	M10x1	4,5	13,5	1	G2.5	2,40			
	16	E9306560016100P	100,0	71,0	–	50,5	39,0	–	44,2	33,0	150,0	51,0-59,0	M12x1	4,5	17,0	1	G2.5	2,60			
	20	E9306560020105P	105,0	76,0	–	52,5	41,0	–	56,0	44,0	155,0	54,0-62,0	M16x1	4,5	21,5	1	G2.5	3,10			
	25	E9306560025115P	115,0	86,0	–	58,5	47,0	87,5	57,1	48,0	165,0	58,0-66,0	M16x1	4,5	25,0	1	G2.5	3,90			
	32	E9306560032115P	115,0	86,0	–	62,5	51,0	87,5	57,2	48,0	165,0	54,0-64,0	M16x1	4,5	25,0	1	G2.5	3,70			

* If LPR = 70, 75 or 85: Extra-short holders requiring a dedicated Easyshrink® cooling contact bush type "5600 extra short", see page(s) 339

** Holder without thread for a stop screw, *** Holder without threaded holes for balancing screw

Accessories

For DCBN-DCBX	Balancing screws
12-16	90ZQ01
20-32	90ZQ01

Spare Parts

For DCBN-DCBX	Sealing plugs	Stop screw
12-16	90AI03	–
20-32	90AI04	19BDR16165

Please check availability in current price and stock-list

(-) For DCBN-DCBX 12 and 16 mm, stop screw not removable/replaceable by the user, please request a repair process

For HSK sealing plugs, coolant tubes and tube spanners, see page(s) 294

EPB 5801 – Shrinkfit holders, Mould and Die type

HSK-A/ ISO12164-1-HSK-A



- Run-out maximum: 3 μm at 3 x ØDCBN-DCBX and 3 μm direct

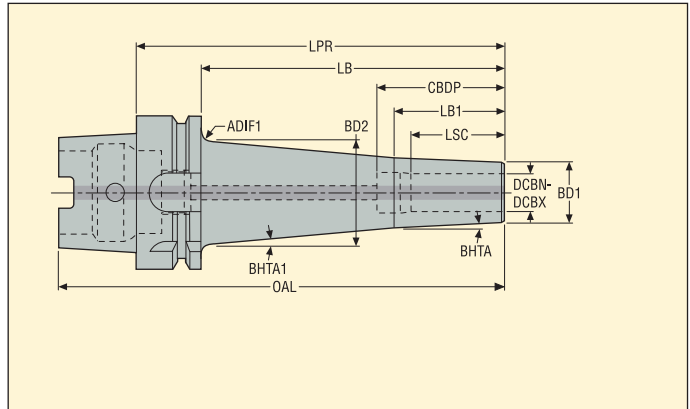

Machine side	Workpiece side	DCBN-DCBX mm	Designation	Dimensions in mm							BHTA°	BHTA1°	ADIF1	RFID hole	Balancing	KG
				LPR	LB	CBDP	LB1	LSC	BD1	BD2						
HSK-A40	3	E930258010370	70,0	50,0	–	50,0	13,0	9,0	15,99	90,0	3,0	5,0	7	0	G2.5	0,23
	3	E9302580103100	100,0	80,0	–	25,0	13,0	9,0	22,00	120,0	3,0	5,0	6	0	G2.5	0,29
	4	E930258010470	70,0	50,0	–	25,0	15,0	10,0	16,99	90,0	3,0	5,0	7	0	G2.5	0,24
	6	E930258010670	70,0	50,0	40,0	50,0	26,0	12,0	18,50	90,0	3,0	5,0	7	0	G2.5	0,29
HSK-A63	3	E9304580103100	100,0	74,0	–	25,0	13,0	9,0	21,00	132,0	3,0	5,0	7	1	G2.5	0,71
	3	E9304580103140	140,0	114,0	–	25,0	13,0	9,0	28,00	172,0	3,0	5,0	7	1	G2.5	0,84
	4	E9304580104100	100,0	74,0	–	25,0	15,0	10,0	22,00	132,0	3,0	5,0	7	1	G2.5	0,72
	4	E9304580104140	140,0	114,0	–	25,0	15,0	10,0	29,00	172,0	3,0	5,0	7	1	G2.5	0,86
	5	E9304580105100	100,0	74,0	–	25,0	18,0	11,0	23,00	132,0	3,0	5,0	7	1	G2.5	0,73
	5	E9304580105140	140,0	114,0	–	25,0	18,0	11,0	30,00	172,0	3,0	5,0	7	1	G2.5	0,89
	6	E9304580106100	100,0	74,0	40,0	32,0	26,0	12,0	23,00	132,0	3,0	5,0	7	1	G2.5	0,74
	6	E9304580106140	140,0	114,0	40,0	32,0	26,0	12,0	30,00	172,0	3,0	5,0	7	1	G2.5	0,91
	8	E9304580108100	100,0	74,0	44,0	36,0	30,0	16,0	27,00	132,0	3,0	5,0	7	1	G2.5	0,80
	8	E9304580108140	140,0	114,0	44,0	36,0	30,0	16,0	34,00	172,0	3,0	5,0	7	1	G2.5	1,11
	10	E9304580110120	120,0	94,0	45,0	38,0	32,0	18,0	32,00	152,0	3,0	5,0	7	1	G2.5	0,94
	10	E9304580110160	160,0	134,0	45,0	38,0	32,0	18,0	39,00	192,0	3,0	5,0	7	1	G2.5	1,25
	12	E9304580112130	130,0	104,0	46,0	40,0	34,0	20,0	36,00	162,0	3,0	5,0	7	1	G2.5	1,05
	12	E9304580112170	170,0	144,0	46,0	40,0	34,0	20,0	43,00	202,0	3,0	5,0	5	1	G2.5	1,41
14	E9304580114180	180,0	154,0	48,0	40,0	34,0	22,0	47,00	112,0	3,0	5,0	3	1	G2.5	1,62	
16	E9304580116150	150,0	124,0	52,0	45,0	38,0	24,0	43,00	182,0	3,0	5,0	5	1	G2.5	1,35	
HSK-A100	6	E9306580106160	160,0	131,0	40,0	131,0	26,0	12,0	33,00	210,0	3,0	5,0	7	1	G2.5	2,29
	8	E9306580108160	160,0	131,0	44,0	36,0	30,0	16,0	37,00	210,0	3,0	5,0	7	1	G2.5	2,42
	10	E9306580110180	180,0	151,0	45,0	38,0	32,0	18,0	42,00	230,0	3,0	5,0	7	1	G2.5	2,68
	12	E9306580112180	180,0	151,0	46,0	40,0	34,0	20,0	44,00	230,0	3,0	5,0	4.5	1	G2.5	2,76
	14	E9306580114180	180,0	151,0	48,0	151,0	34,0	22,0	46,00	230,0	3,0	5,0	7	1	G2.5	2,90
	16	E9306580116200	200,0	171,0	52,0	45,0	38,0	24,0	51,00	250,0	3,0	5,0	7	1	G2.5	3,24

Please check availability in current price and stock-list

For Shrinkfit extensions, see page(s) 221

For HSK sealing plugs, coolant tubes and tube spanners, see page(s) 294

EPB 5672 – High precision collet chucks

HSK-A/ ISO12164-1-HSK-A



- Run-out 3 µm maximum at 3 x ØDCBN-DCBX
- High transmittable torque
- High RPM suitable

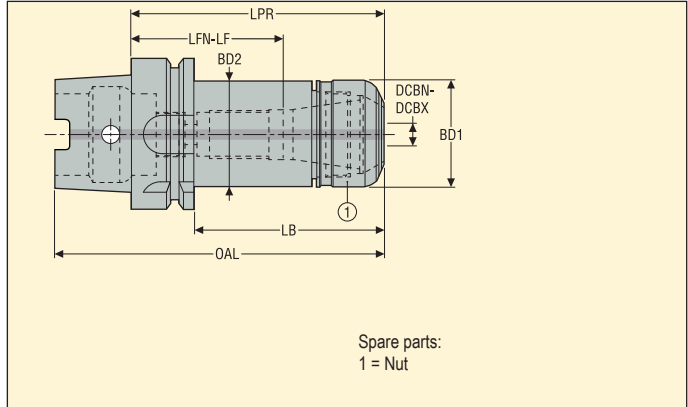

Machine side	Workpiece side	Capacity DCBN-DCBX mm	Designation	Chuck & Collet Size	Dimensions in mm					**	RFID hole	Balancing	KG	
					LPR	BD1	BD2	OAL	LB					LFN-LF*
HSK-A40		0,5-10,0	E930256721660	HP 16	60,0	30,0	30,0	80,0	40,0	29,0-30,0	**	0	G2.5	0,36
HSK-A63		0,5-7,0	E9304567211100	HP 11	100,0	16,0	16,0	132,0	74,0	64,0-82,0		1	G2.5	0,8
		0,5-10,0	E930456721660	HP 16	60,0	30,0	30,0	92,0	34,0	29,0-30,0	**	1	G2.5	0,77
		0,5-10,0	E9304567216100	HP 16	100,0	30,0	30,0	132,0	74,0	69,0-70,0		1	G2.5	0,96
		0,5-10,0	E9304567216130	HP 16	130,0	30,0	30,0	162,0	104,0	99,0-100,0		1	G2.5	1,11
		0,5-10,0	E9304567216160	HP 16	160,0	30,0	30,0	192,0	134,0	129,0-130,0		1	G2.5	1,26
		1,0-16,0	E9304567225100	HP 25	100,0	40,0	40,0	132,0	74,0	44,0-62,0		1	G2.5	1,16
		1,0-16,0	E9304567225130	HP 25	130,0	40,0	40,0	162,0	104,0	74,0-92,0		1	G2.5	1,42
		1,0-16,0	E9304567225160	HP 25	160,0	40,0	40,0	192,0	134,0	104,0-122,0		1	G2.5	1,69
		2,0-20,0	E9304567232100	HP 32	100,0	50,0	50,0	132,0	74,0	44,0-48,0		1	G2.5	1,42
		2,0-20,0	E9304567232130	HP 32	130,0	50,0	50,0	162,0	104,0	74,0-78,0		1	G2.5	1,84
	2,0-20,0	E9304567232160	HP 32	160,0	50,0	50,0	192,0	134,0	104,0-108,0		1	G2.5	2,27	
HSK-A100		1,0-16,0	E9306567225160	HP 25	160,0	40,0	40,0	210,0	131,0	104,0-122,0		1	G2.5	2,99
		2,0-20,0	E9306567232100	HP 32	100,0	50,0	50,0	150,0	71,0	44,0-48,0		1	G2.5	2,74
		2,0-20,0	E9306567232160	HP 32	160,0	50,0	50,0	210,0	131,0	104,0-108,0		1	G2.5	3,55

For ER HP collets type 5672, see page(s) 309-313

* LFN-LF setting length onto stop screw when possible, or total available setting length for chucks without thread for stop screw, ** Chuck without thread for stop screw

Accessories***

Spare Parts

For size	Socket	Spanner	Stop screw	Torque key	Nut
HP 11	03ER016	03BR016	19B5870812P1	03DYD010100	08B567211
HP 16	03ER030	03BR030	19B58711	03DYD010100	08B567216
HP 25	03ER040	03BR040	19B58718	03DYD020200	08B567225
HP 32	03ER050	03BR050	19B58722	03DYD020200	08B567232

Please check availability in current price and stock-list

** When using a stop screw, its tapered contact onto the tool shank can increase the tool run-out defect, For tightening torques, see page(s) 41

For HSK sealing plugs, coolant tubes and tube spanners, see page(s) 294

EPB 5834 – Hydraulic chucks - DIN 69882-7

HSK-A/ ISO12164-1-HSK-A



- Run-out 3 μm maximum at 3 x ØDCBN-DCBX

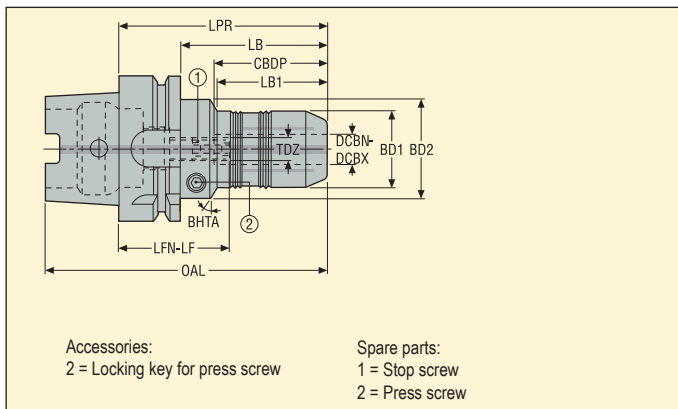

Machine side	Workpiece side	Designation	Dimensions in mm									TDZ	*	BHTA*	RFID hole	Balancing	KG
			LPR	LB	CBDP	LB1	BD2	BD1	OAL	LFN-LF							
HSK-A63	DCBN-DCBX mm																
	6	E930458340670	70,0	44,0	38,0	23,0	50,0	26,0	102,0	32,0-42,0	M5	*	30,0	1	G6.3	0,97	
	8	E930458340870	70,0	44,0	38,0	24,0	50,0	28,0	102,0	32,0-42,0	M5	*	30,0	1	G6.3	0,97	
	10	E930458341080	80,0	54,0	42,0	34,0	50,0	30,0	112,0	38,0-48,0	M8	*	30,0	1	G6.3	1,04	
	12	E930458341285	85,0	59,0	47,0	40,0	50,0	32,0	117,0	38,0-48,0	M10	*	30,0	1	G6.3	1,07	
	14	E930458341485	85,0	59,0	47,0	40,0	50,0	34,0	117,0	38,0-48,0	M10	*	30,0	1	G6.3	1,09	
	16	E930458341690	90,0	64,0	50,0	46,0	50,0	38,0	122,0	40,0-50,0	M10	*	30,0	1	G6.3	1,18	
	18	E930458341890	90,0	64,0	50,0	48,0	50,0	40,0	122,0	40,0-50,0	M10	*	30,0	1	G6.3	1,19	
	20	E930458342090	90,0	64,0	52,0	47,0	50,0	42,0	122,0	38,0-48,0	M10	*	30,0	1	G6.3	1,22	
	25	E9304583425120	120,0	94,0	58,0	78,0	53,0	58,0	152,0	62,0-72,0	M10	*	60,0	1	G6.3	2,19	
32	E9304583432125	125,0	125,0	63,0	-	53,0	64,0	157,0	64,0-74,0	M10	*	90,0	1	G6.3	2,46		
HSK-A100	12	E930658341295	95,0	66,0	47,0	40,0	50,0	32,0	145,0	48,0-58,0	M10	*	30,0	1	G6.3	2,50	
	16	E930658341695	95,0	66,0	50,0	46,0	50,0	38,0	145,0	45,0-55,0	M10	*	30,0	1	G6.3	2,53	
	20	E9306583420105	105,0	76,0	52,0	47,0	50,0	42,0	155,0	53,0-63,0	M10	*	30,0	1	G6.3	2,83	
	25	E9306583425110	110,0	81,0	58,0	50,0	70,0	58,0	160,0	52,0-62,0	M10	*	30,0	1	G6.3	3,58	
	32	E9306583432110	110,0	81,0	63,0	60,0	70,0	64,0	160,0	47,0-57,0	M10	*	30,0	1	G6.3	3,60	

For reduction sleeves and control gauges, see page(s) 307-308

* Conform to DIN 69882-7

Accessories

For Taper/ DCBN-DCBX	Locking key
HSK-A63/ 6-8	H04-4
HSK-A63/ 10	H04-4
HSK-A63/ 12	H04-4
HSK-A63/ 14-20	H04-4
HSK-A63/ 25-32	H04-4
HSK-A100/ 12	H04-4
HSK-A100/ 16-32	H04-4

Spare Parts

Press screw	Stop screw
950AF0810008	19LS0512A
950AF0810008	19LS0820T
950AF0810008	19LS1016A
950AF1010010	19LS1016A
950AF1010010	19LS1020A
950AF0810008	19LS1020A
950AF1010010	19LS1020A

Please check availability in current price and stock-list

For HSK sealing plugs, coolant tubes and tube spanners, see page(s) 294

EPB 5831 – Hydraulic chucks, slim

HSK-A/ ISO12164-1-HSK-A



- Run-out 5 µm maximum at 3 x ØDCBN-DCBX

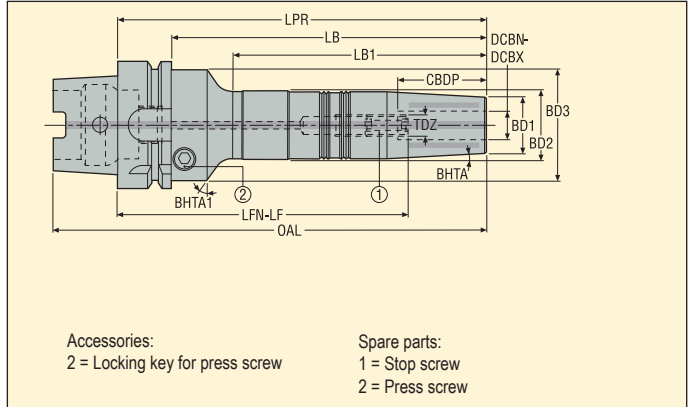

Machine side	Workpiece side	DCBN-DCBX mm	Designation	Dimensions in mm										TDZ	BHTA°	BHTA1°	RFID hole	Balancing	KG
				LPR	LB	LB1	CDBP	BD3	BD2	BD1	OAL	LFN-LF							
HSK-A63	6	E9304583106150	150,0	150,0	94,3	37,0	53,0	26,0	21,0	182,0	123,0-113,0	M5	3,0	30,0	1	G6.3	1,40		
	6	E9304583106200	200,0	200,0	144,3	37,0	53,0	26,5	21,0	232,0	173,0-163,0	M5	3,0	30,0	1	G6.3	1,50		
	8	E9304583108150	150,0	150,0	94,3	37,0	53,0	28,0	23,0	182,0	123,0-113,0	M6	3,0	30,0	1	G6.3	1,40		
	8	E9304583108200	200,0	174,0	144,3	37,0	53,0	28,5	23,0	232,0	173,0-163,0	M6	3,0	30,0	1	G6.3	1,60		
	10	E9304583110150	150,0	124,0	94,3	42,0	53,0	30,0	25,0	182,0	118,0-108,0	M8	3,0	30,0	1	G6.3	1,50		
	10	E9304583110200	200,0	200,0	144,3	42,0	53,0	30,5	25,0	232,0	168,0-158,0	M8	3,0	30,0	1	G6.3	1,70		
	12	E9304583112150	150,0	150,0	94,3	47,0	53,0	32,0	27,0	182,0	113,0-103,0	M10	3,0	30,0	1	G6.3	1,60		
	12	E9304583112200	200,0	174,0	141,3	47,0	53,0	32,5	27,0	232,0	163,0-153,0	M10	3,0	30,0	1	G6.3	1,80		
HSK-A100	6	E9306583106150	150,0	121,0	91,3	37,0	53,0	26,0	21,0	200,0	123,0-113,0	M5	3,0	30,0	1	G6.3	2,70		
	6	E9306583106200	200,0	171,0	141,3	37,0	53,0	26,5	21,0	250,0	173,0-163,0	M5	3,0	30,0	1	G6.3	2,90		
	8	E9306583108150	150,0	121,0	91,3	37,0	53,0	28,0	23,0	200,0	123,0-113,0	M6	3,0	30,0	1	G6.3	2,70		
	8	E9306583108200	200,0	171,0	141,3	37,0	53,0	28,5	23,0	250,0	173,0-163,0	M6	3,0	30,0	1	G6.3	3,00		
	10	E9306583110150	150,0	121,0	91,3	42,0	53,0	30,0	25,0	200,0	118,0-108,0	M8	3,0	30,0	1	G6.3	2,80		
	10	E9306583110200	200,0	171,0	141,3	42,0	53,0	30,5	25,0	250,0	168,0-158,0	M8	3,0	30,0	1	G6.3	3,00		
	12	E9306583112150	150,0	121,0	91,3	47,0	53,0	32,0	27,0	200,0	113,0-103,0	M10	3,0	30,0	1	G6.3	2,90		
	12	E9306583112200	200,0	171,0	141,3	47,0	53,0	32,5	27,0	250,0	163,0-153,0	M10	3,0	30,0	1	G6.3	3,20		

For reduction sleeves and control gauges, see page(s) 307-308

Accessories

For DCBN-DCBX	Locking key
6	H04-4
8	H04-4
10	H04-4
12	H04-4

Spare Parts

For DCBN-DCBX	Press screw	Stop screw
6	950AF1010010	19LS0516A
8	950AF1010010	19LS0620A
10	950AF1010010	19LS0820A
12	950AF1010010	19LS1020A

Please check availability in current price and stock-list

For HSK sealing plugs, coolant tubes and tube spanners, see page(s) 294

EPB 5675 – ER collet chucks – ISO 15488

HSK-A/ ISO12164-1-HSK-A



- Run-out 10 µm maximum at 3 x ØDCBN-DCBX

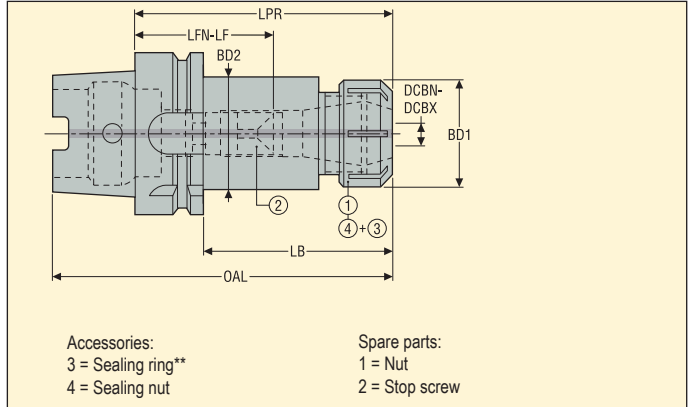

Machine side	Workpiece side	Capacity DCBN-DCBX mm	Designation	Chuck & Collet Size	Dimensions in mm					*	RFID hole	Balancing	KG
					LPR	BD2	BD1	OAL	LB				
HSK-A40	0,5-10,0	E930256751660	ER 16	60,0	32,0	32,0	80,0	40,0	26,0-30,0		0	G2.5	0,35
	1,0-16,0	E930256752570	ER 25	70,0	34,0	42,0	90,0	50,0	–		0	G2.5	0,44
HSK-A63	0,5-10,0	E9304567516100	ER 16	100,0	32,0	32,0	132,0	74,0	52,0-68,0		1	G2.5	0,99
	0,5-10,0	E9304567516160	ER 16	160,0	32,0	32,0	192,0	134,0	112,0-128,0	*	1	G2.5	1,35
	1,0-16,0	E9304567525100	ER 25	100,0	41,7	42,0	132,0	–	44,0-62,0	*	1	G2.5	1,21
	1,0-16,0	E9304567525160	ER 25	160,0	41,7	42,0	192,0	–	91,0-122,0		1	G2.5	1,82
	2,0-20,0	E9304567532100	ER 32	100,0	50,0	50,0	132,0	74,0	45,0-60,0	*	1	G2.5	1,4
	2,0-20,0	E9304567532160	ER 32	160,0	50,0	50,0	192,0	134,0	92,0-120,0		1	G2.5	2,28
	3,0-26,0	E9304567540120	ER 40	120,0	53,0	63,0	152,0	94,0	53,0-75,0	*	1	G2.5	1,81
HSK-A100	1,0-16,0	E9306567525100	ER 25	100,0	41,7	42,0	150,0	71,0	43,0-62,0		1	G2.5	2,54
	1,0-16,0	E9306567525160	ER 25	160,0	41,7	42,0	210,0	131,0	103,0-122,0		1	G2.5	3,14
	2,0-20,0	E9306567532100	ER 32	100,0	50,0	50,0	150,0	71,0	53,0-60,0	*	1	G2.5	2,73
	2,0-20,0	E9306567532160	ER 32	160,0	41,7	50,0	210,0	131,0	103,0-120,0		1	G2.5	3,57
	3,0-26,0	E9306567540120	ER 40	120,0	63,0	63,0	170,0	91,0	58,0-75,0	*	1	G2.5	3,56

For ER extensions and ER collets, see page(s) 222, 314-315

* Conform to DIN 69882-2

Accessories**

For size	Seal nut	Socket	Spanner	Spanner 1	Torque key
ER 16	08B587516IC	03ER032	03B587516	03BR032	03DYD010100
ER 25	08B587525IC	03ER042	03B587525	03BR042	03DYD020200
ER 32	08B587532IC	03ER050	03B587532	03BR050	03DYD020200
ER 40	08B587540IC	03ER063	03B587540	03BR063	03DYD020200

Spare Parts

Nut	Stop screw
08B587516X	19B58711
08B587525X	19B58718
08B587532X	19B58722
08B587540X	19B58730

Please check availability in current price and stock-list

** For ER sealing rings, see page(s) 320

For HSK sealing plugs, coolant tubes and tube spanners, see page(s) 294

EPB 5085 – Adjustable drill chucks

HSK-A/ ISO12164-1-HSK-A



- Run-out 40 µm maximum at 2,5 x ØDCBN-DCBX

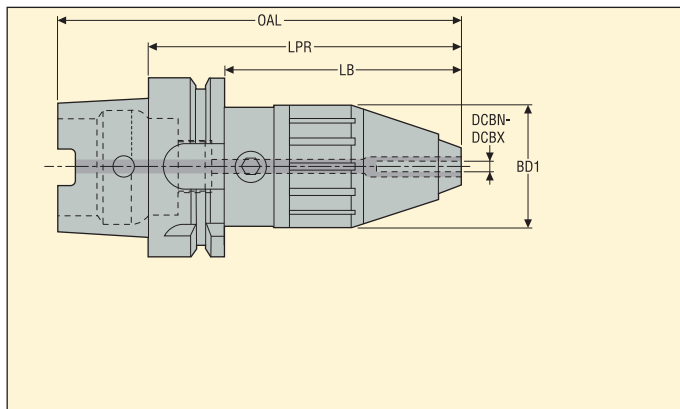

Machine side	Workpiece side	Capacity DCBN-DCBX mm	Designation	Dimensions in mm				RFID hole	Balancing	 KG
				OAL	LPR	LB	BD1			
Taper										
HSK-A63		1,0-13,0	E9304508513	142,0	110,0	84,0	43,0	1	PB	2,00
HSK-A100		2,5-16,0	E9306508516	184,0	134,0	105,0	56,0	1	PB	3,26

Accessories

For	Key
E9304508513	H06-4
E9306508516	H06-4

Please check availability in current price and stock-list
 For HSK sealing plugs, coolant tubes and tube spanners, see page(s) 294

EPB 5867 – Tapping chucks for synchronized tapping, with micro-compensation

HSK-A/ ISO12164-1-HSK-A

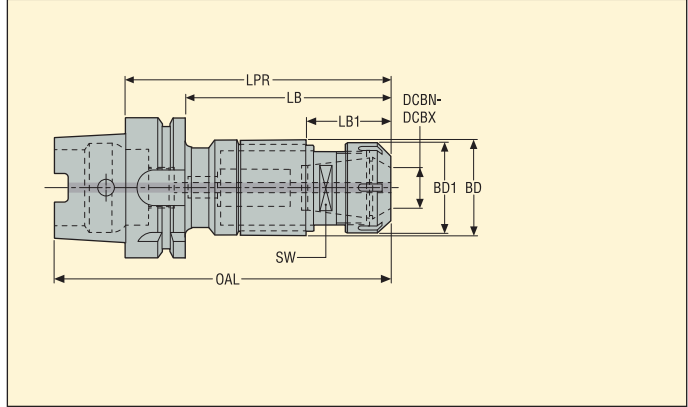

- Inbuilt axial micro flexure ($\pm 0,5$ mm) prevents from tap stress
- Tap fitting based on ER tapping collets with square drive
- Maximum coolant pressure 80 bar

Machine side	Workpiece side		Designation	Dimensions in mm							RFID hole	Balancing	KG	
	Taper	Size		Tapping range	LPR	LB2	LB1	BD	BD1	OAL				SW
HSK-A63		ER 20	M4-M12	E9304586720108	108,1	82,2	40,3	35,0	33,7	140,0	22,0	1	PB	1,10
		ER 25	M8-M20	E9304586725128	127,5	101,5	42,1	44,0	42,0	159,4	28,0	1	PB	1,50
		ER 40	M16-M33	E9304586740160	159,9	133,9	52,0	62,0	62,7	191,8	39,6	1	PB	2,90
HSK-A100		ER 20	M4-M12	E9306586720115	114,6	85,7	40,3	35,0	33,7	164,5	22,0	1	PB	4,20
		ER 25	M8-M20	E9306586725134	134,0	105,0	42,1	44,0	42,0	183,9	28,0	1	PB	2,50
		ER 40	M16-M33	E9306586740163	163,4	134,4	52,0	62,0	62,7	213,3	39,6	1	PB	2,90

For ER tapping collets with square drive, see page(s) 316

Accessories

For Taper/ size	Locking key	Socket	Spanner	Spanner 1	Torque key	Nut
HSK-A63/ ER 20	5680092-04	-	03B587520UM	-	-	5533051-02
HSK-A63/ ER 25	5680092-05	03ER042	03B587525	03BR042	03DYD020200	5533051-03
HSK-A63/ ER 40	5680092-06	03ER063	03B587540	03BR063	03DYD020200	5533051-05
HSK-A100/ ER 20	5680092-04	-	03B587520UM	-	-	5533051-02
HSK-A100/ ER 25	5680092-05	03ER042	03E9306	03BR042	03DYD020200	5533051-03
HSK-A100/ ER 40	5680092-06	03ER063	03B587540	03BR063	03DYD020200	5533051-05

Please check availability in current price and stock-list

For EPB 5867 sealing rings, see page(s) 320

For HSK sealing plugs, coolant tubes and tube spanners, see page(s) 294

EPB 586 – Control bars

HSK-A/ ISO12164-1-HSK-A

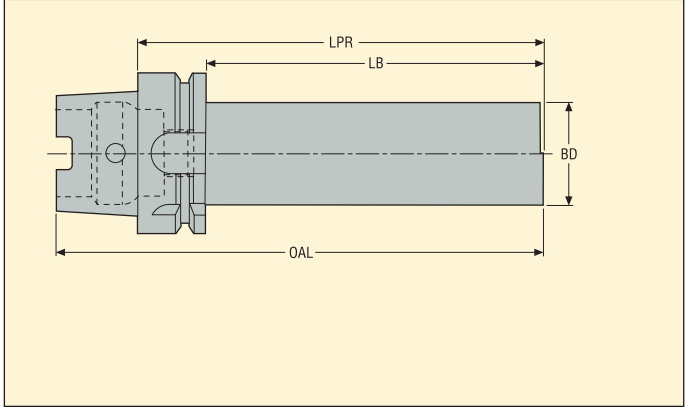

- With protective case and measurement report

Machine side	Designation	Dimensions in mm				RFID hole	Balancing	
		LPR	LB	BD	OAL			
HSK-A63	E930458640250	250,0	224,0	40,0	250,0	1	-	2,90
HSK-A100	E930658650320	320,0	291,0	50,0	320,0	1	-	6,40

Please check availability in current price and stock-list
 For HSK sealing plugs, coolant tubes and tube spanners, see page(s) 294

EPB K820-K821 – Steadyline® vibration damping Combimaster arbors

HSK-A

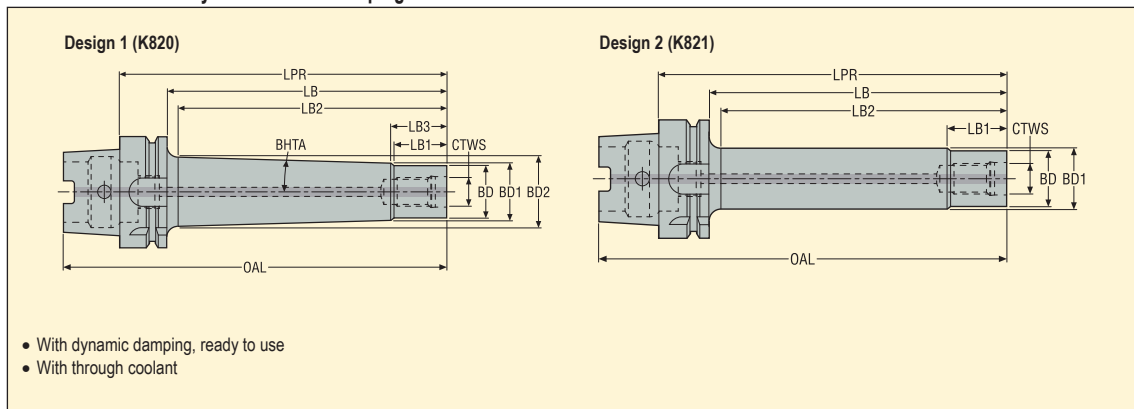

Machine side	Workpiece side	Designation	Dimensions in mm									BHTA°	Design	Max. RPM	RFID hole	Balancing	KG
			LPR	LB	LB2	LB1	BD	BD2	BD1	OAL							
HSK-A63	M10	E9304K82010185	185,0	159,0	154,2	20,0	18,5	36,6	24,0	217,0	2,8	1	12000	1	PB	1,51	
	M12	E9304K82012185	185,0	159,0	154,2	20,0	23,0	42,0	29,5	217,0	2,8	1	12000	1	PB	1,90	
	M16	E9304K82016185	185,0	159,0	154,2	20,0	30,0	59,5	37,0	217,0	2,8	1	10000	1	PB	2,59	
	M16	E9304K82016235	235,0	209,0	190,6	20,0	30,0	53,0	37,0	267,0	2,8	1	8000	1	PB	3,50	
	M16	E9304K82116160	160,0	134,0	129,0	22,0	30,0	30,5	30,5	192,0	–	2	10000	1	PB	1,40	
	M20	E9304K82020185	185,0	159,0	140,2	24,7	36,5	55,7	45,0	217,0	2,7	1	10000	1	PB	3,30	
	M20	E9304K82020235	235,0	209,0	186,4	24,7	36,5	60,1	45,0	267,0	2,7	1	8000	1	PB	4,30	
HSK-A100	M12	E9306K82012235	235,0	206,0	201,2	20,0	23,0	46,6	29,5	285,0	2,8	1	8000	1	PB	4,00	
	M16	E9306K82016235	235,0	206,0	201,2	20,0	30,0	54,0	37,0	285,0	2,8	1	8000	1	PB	4,78	
	M16	E9306K82016285	285,0	256,0	251,2	20,0	30,0	58,8	37,0	335,0	2,8	1	6000	1	PB	5,86	
	M16	E9306K82116185	185,0	156,0	151,0	22,0	30,0	30,5	30,5	235,0	–	2	8000	1	PB	2,91	
	M20	E9306K82020235	235,0	206,0	201,2	24,7	36,5	61,6	45,0	285,0	2,7	1	8000	1	PB	5,70	
	M20	E9306K82020285	285,0	256,0	251,2	24,7	36,5	66,4	45,0	335,0	2,7	1	6000	1	PB	7,20	

Please check availability in current price and stock-list
 For HSK sealing plugs, coolant tubes and tube spanners, see page(s) 294

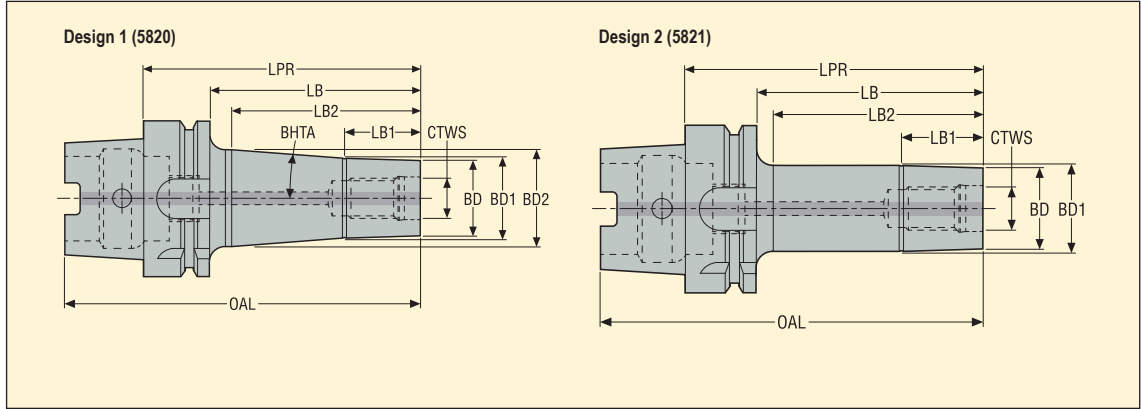

Machine side	Workpiece side	Designation	Dimensions in mm									BHTA°	Design	RFID hole	Balancing	KG
			LPR	LB	LB2	LB1	BD	BD2	BD1	OAL						
HSK-A63	Combimaster CTWS	M6 E930458200660	60,0	34,0	25,0	10,0	11,0	14,5	11,7	92,0	5,3	1	1	G6.3	0,70	
		M8 E930458200860	60,0	34,0	25,0	10,0	13,5	18,5	15,7	92,0	5,3	1	1	G6.3	0,70	
		M8 E930458200885	85,0	59,0	50,0	15,0	13,5	20,0	15,7	117,0	3,5	1	1	G6.3	0,80	
		M10 E930458201060	60,0	34,0	25,0	10,0	18,5	23,0	19,7	92,0	6,3	1	1	G6.3	0,80	
		M10 E930458201085	85,0	59,0	50,0	15,0	18,5	24,5	19,7	117,0	3,9	1	1	G6.3	0,80	
		M10 E9304582010135	135,0	109,0	100,0	20,0	18,5	27,5	19,7	167,0	2,8	1	1	G6.3	1,00	
		M10 E930458211060	60,0	34,0	25,0	10,0	18,5	18,5	18,5	92,0	-	2	1	G6.3	0,70	
		M12 E930458201260	60,0	34,0	25,0	10,0	23,0	28,5	24,7	92,0	7,2	1	1	G6.3	0,80	
		M12 E930458201285	85,0	59,0	50,0	20,0	23,0	30,0	24,7	117,0	5,0	1	1	G6.3	0,90	
		M12 E9304582012110	110,0	84,0	75,0	25,0	23,0	31,5	24,7	142,0	3,9	1	1	G6.3	1,00	
		M12 E9304582012135	135,0	109,0	100,0	30,0	23,0	33,0	24,7	167,0	3,4	1	1	G6.3	1,20	
		M12 E930458211260	60,0	34,0	25,0	10,0	23,0	23,5	23,5	92,0	-	2	1	G6.3	0,80	
		M12 E930458211285	85,0	59,0	50,0	20,0	23,0	23,5	23,5	117,0	-	2	1	G6.3	0,80	
		M16 E930458201660	60,0	34,0	25,0	10,0	30,0	35,5	31,7	92,0	6,9	1	1	G6.3	0,90	
		M16 E930458201685	85,0	59,0	50,0	20,0	30,0	37,0	31,7	117,0	5,0	1	1	G6.3	1,10	
		M16 E9304582016110	110,0	84,0	75,0	25,0	30,0	38,5	31,7	142,0	3,9	1	1	G6.3	1,20	
		M16 E9304582016135	135,0	109,0	100,0	30,0	30,0	40,0	31,7	167,0	3,4	1	1	G6.3	1,40	
		M16 E9304582016185	185,0	159,0	150,0	35,0	30,0	50,0	31,7	217,0	4,5	1	1	G6.3	2,10	
		M16 E930458211685	85,0	59,0	50,0	20,0	30,0	30,5	30,5	117,0	-	2	1	G6.3	1,00	
		M16 E9304582116110	110,0	84,0	77,0	25,0	30,0	30,5	30,5	142,0	-	2	1	G6.3	1,10	
M16 E9304582116135	135,0	109,0	100,0	30,0	30,0	30,5	30,5	167,0	-	2	1	G6.3	1,20			
M20 E930458202065	65,0	39,0	30,0	10,0	36,5	44,5	37,5	97,0	6,4	1	1	G6.3	1,00			
M20 E9304582020110	110,0	84,0	75,0	25,0	36,5	44,5	37,5	142,0	6,5	1	1	G6.3	1,40			
M20 E9304582120110	110,0	84,0	75,0	25,0	36,5	37,0	37,0	142,0	-	2	1	G6.3	1,20			
HSK-A100	Combimaster CTWS	M10 E930658201085	85,0	56,0	50,0	15,0	18,5	27,0	19,7	135,0	7,6	1	1	G6.3	2,20	
		M12 E930658201285	85,0	56,0	50,0	20,0	23,0	35,0	24,7	135,0	9,7	1	1	G6.3	2,30	
		M12 E9306582012110	110,0	81,0	75,0	25,0	23,0	38,0	24,7	160,0	7,6	1	1	G6.3	2,40	
		M12 E9306582012135	135,0	106,0	100,0	30,0	23,0	41,0	24,7	185,0	6,6	1	1	G6.3	2,60	
		M12 E9306582012185	185,0	156,0	150,0	30,0	23,0	42,5	24,7	235,0	4,2	1	1	G6.3	2,90	
		M16 E930658201685	85,0	56,0	50,0	30,0	30,0	42,5	31,7	135,0	10,2	1	1	G6.3	2,40	
		M16 E9306582016135	135,0	106,0	100,0	30,0	30,0	49,0	31,7	185,0	7,0	1	1	G6.3	2,90	
		M16 E9306582016185	185,0	156,0	150,0	35,0	30,0	50,0	31,7	235,0	4,5	1	1	G6.3	3,30	
		M20 E930658202075	75,0	46,0	40,0	20,0	36,5	47,5	37,5	125,0	14,1	1	1	G6.3	2,40	
		M20 E9306582020135	135,0	106,0	100,0	30,0	36,5	54,5	37,5	185,0	6,9	1	1	G6.3	3,10	
		M20 E9306582120110	110,0	81,0	75,0	25,0	36,5	37,0	37,0	160,0	-	2	1	G6.3	2,60	

Please check availability in current price and stock-list
 For HSK sealing plugs, coolant tubes and tube spanners, see page(s) 294

EPB 401 – Graflex® arbors

HSK-A

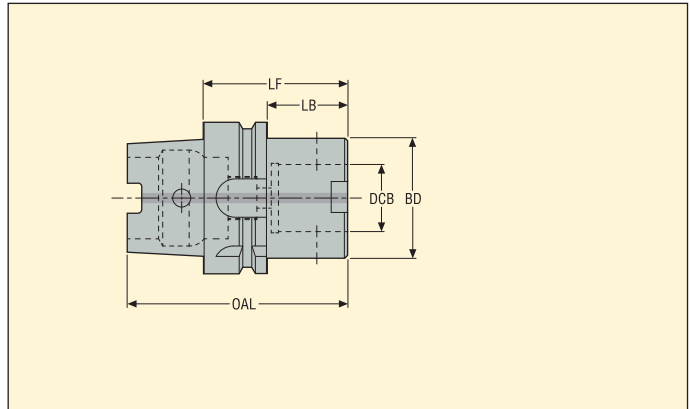

Machine side	Workpiece side Graflex		Designation	Dimensions in mm				RFID hole	Balancing	KG
	Taper	Size		DCB mm	LF	LB	BD			
HSK-A50	G5	28	EM93034012870	70,0	44,0	50,0	95,0	0	PB	0,79
HSK-A63	G2	14	EM93044011445	45,0	19,0	25,0	77,0	1	G6.3	0,69
	G3	18	EM93044011850	50,0	24,0	32,0	82,0	1	G6.3	0,73
	G4	22	EM93044012255	55,0	29,0	40,0	87,0	1	G6.3	0,83
	G5	28	EM93044012860	60,0	34,0	50,0	92,0	1	PB	0,98
	G5	28	EM930440128100	100,0	74,0	50,0	132,0	1	PB	1,58
	G5	28	EM930440128140	140,0	114,0	50,0	172,0	1	PB	2,18
	G6	36	EM93044013670	70,0	44,0	63,0	102,0	1	PB	1,21
	G6	36	EM930440136120	120,0	94,0	63,0	152,0	1	PB	2,38
HSK-A100	G3	18	EM93064011855	55,0	26,0	32,0	105,0	1	G6.3	2,10
	G4	22	EM93064012260	60,0	31,0	40,0	110,0	1	G6.3	2,19
	G5	28	EM93064012865	65,0	36,0	50,0	115,0	1	PB	2,37
	G5	28	EM930640128110	110,0	81,0	50,0	160,0	1	PB	3,02
	G5	28	EM930640128150	150,0	121,0	50,0	200,0	1	PB	3,70
	G6	36	EM93064013675	75,0	46,0	63,0	125,0	1	PB	2,60
	G6	36	EM930640136120	120,0	91,0	63,0	170,0	1	PB	3,82
	G6	36	EM930640136160	160,0	131,0	63,0	210,0	1	PB	4,72
	G7	46	EM93064014685	85,0	56,0	90,0	135,0	1	PB	3,99
	G7	46	EM930640146160	160,0	131,0	90,0	210,0	1	PB	7,67

Accessories

For size	Locking key
G2	03H025
G3	03H03
G4	03H04
G5	03H05
G6	03H06
G7	03H10

Spare Parts

For size	Assembly screw
G2	90F2
G3	90F3
G4	90F4
G5	90F5
G6	90F6
G7	90F7

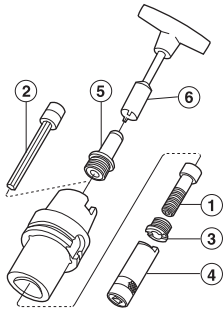

Please check availability in current price and stock-list
 For HSK sealing plugs, coolant tubes and tube spanners, see page(s) 294



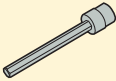

Accessories:
 2 = Extension key
 4 = Spanner
 6 = Key for coolant tube

Spare parts:
 1 = Centre screw
 3 = Retaining nut
 5 = Coolant tube*

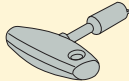
Accessories

For	Extension Key	Key	Spanner
			
C3-390.410-63075C	5680015-05	5680094-04	5680065-13
C3-390.410-100080A	5680015-05	5680094-06	5680065-13
C4-390.410-63080C	5680015-05	5680094-04	5680065-10
C4-390.410-100090A	5680015-05	5680094-06	5680065-10
C5-390.410-63090C	5680015-01	5680094-04	5680065-11
C5-390.410-100100A	5680015-01	5680094-06	5680065-11
C6-390.410-100110A	5680015-02	5680094-06	5680065-12
C8-390.410-100120A	5680015-02	5680094-06	5680065-12

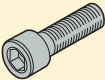
Spare Parts*

For	Centre screw	Coolant tube	Retaining nut
			
C3-390.410-63075C	5512063-10	5692020-04	5512091-04
C3-390.410-100080A	5512063-10	5692020-06	5512091-04
C4-390.410-63080C	5512063-07	5692020-04	5512091-03
C4-390.410-100090A	5512063-07	5692020-06	5512091-03
C5-390.410-63090C	5512063-08	5692020-04	5512091-01
C5-390.410-100100A	5512063-08	5692020-06	5512091-01
C6-390.410-100110A	5512063-09	5692020-06	5512091-02
C8-390.410-100120A	5512063-09	5692020-06	5512091-02

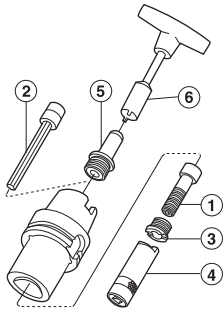

* A specific coolant tube is delivered together with each Seco-Capto™ HSK basic holder



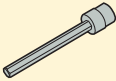

Accessories:
 2 = Extension key
 4 = Retaining nut spacer
 6 = Key for coolant tube

Spare parts:
 1 = Centre screw
 3 = Retaining nut
 5 = Coolant tube*

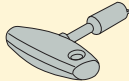
Accessories

For	Extension key	Key	Spanner
			
C4-390.411-63080	5680015-05	5680094-04	5680065-10
C4-390.411-100090	5680015-05	5680094-06	5680065-10
C5-390.411-63090	5680015-01	5680094-04	5680065-11
C5-390.411-100100	5680015-01	5680094-06	5680065-11
C6-390.411-100110	5680015-02	5680094-06	5680065-12
C8-390.411-100120	5680015-02	5680094-06	5680065-12

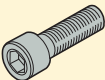
Spare Parts*

For	Centre screw	Coolant tube	Retaining nut
			
C4-390.411-63080	5512063-07	5692020-04	5512091-03
C4-390.411-100090	5512063-07	5692020-06	5512091-03
C5-390.411-63090	5512063-08	5692020-04	5512091-01
C5-390.411-100100	5512063-08	5692020-06	5512091-01
C6-390.411-100110	5512063-09	5692020-06	5512091-02
C8-390.411-100120	5512063-09	5692020-06	5512091-02

* A specific coolant tube is delivered together with each Seco-Capto™ HSK basic holder

EPB 5603 – Shrinkfit holders, DIN type

HSK-E



- Run-out maximum: 3 µm at 3 x ØDCBN-DCBX and 3 µm direct
- Delivered with one stop screw

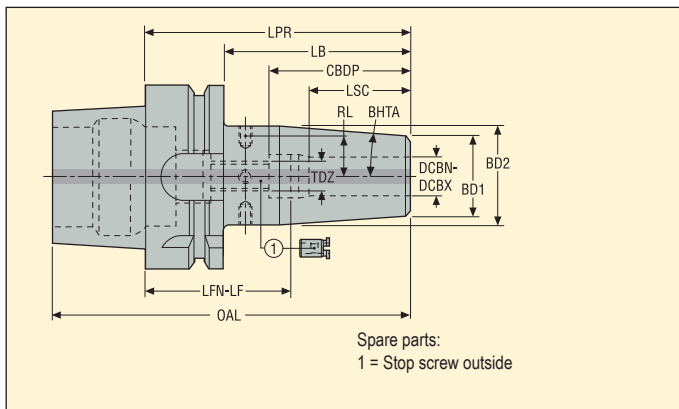

Machine side	Workpiece side	Designation	Dimensions in mm								TDZ	BHTA°	RL mm	**	RFID hole	Balancing	KG
			LPR	LB	CBDP	LSC	BD2	BD1	OAL	LFN-LF							
HSK-E40	3	E934256030350	50,0	30,0	31,0	13,0	20,0	15,0	70,0	20,5-37,0	M5x0.8	4,5	10,5	**	0	G2.5	0,30
	4	E934256030450	50,0	30,0	31,0	15,0	20,0	15,0	70,0	20,5-35,0	M5x0.8	4,5	10,5	**	0	G2.5	0,30
	6	E934256030650	50,0	30,0	31,0	22,0	27,0	21,0	70,0	20,5-28,0	M5x0.8	4,5	10,5	**	0	G2.5	0,30
	6	E934256030670	70,0	50,0	37,5	22,0	27,0	21,0	90,0	34,0-44,0	M5x0.8	4,5	10,5		0	G2.5	0,40
	8	E934256030870	70,0	50,0	37,5	26,0	27,0	21,0	90,0	34,0-44,0	M6x1	4,5	10,5		0	G2.5	0,36
	10	E934256031055	55,0	35,0	36,0	31,0	32,0	24,0	75,0	20,5-24,0	M8x1	4,5	13,0	**	0	G2.5	0,40
	12	E934256031260	60,0	40,0	41,0	34,0	32,0	24,0	80,0	20,5-26,0	M10x1	4,5	13,0	**	0	G2.5	0,40
	16	E934256031665	65,0	45,0	46,0	39,0	34,0	27,0	85,0	20,5-26,0	M12x1	4,5	14,0	**	0	G2.5	0,40

** Extra-short holder, without thread for a stop screw nor threaded holes for balancing screws and requiring a dedicated Easyshrink® cooling contact bush type '5603 extra-short', see page(s) 339. For Shrinkfit extensions, see page(s) 221

Accessories

For	Balancing screws
E934256030670	90ZQ01
E934256030870	90ZQ01

Spare Parts

For	Stop screw
E934256030670	19BDR05165
E934256030870	19BDR06165

Please check availability in current price and stock-list

* For HSK sealing plugs, coolant tubes and tube spanners, see page(s) 294

EPB 5603 – Shrinkfit holders, DIN type

HSK-E

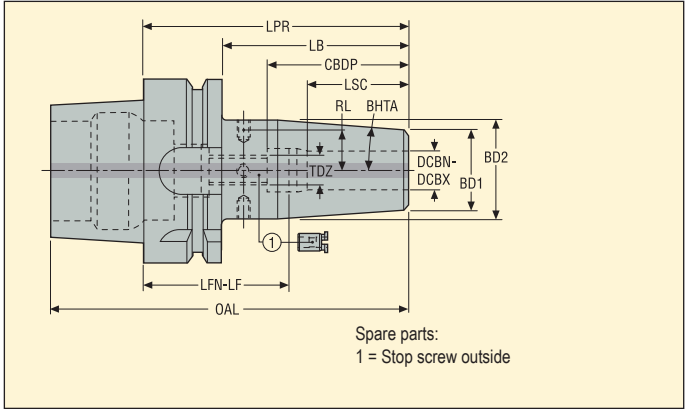

- Run-out maximum: 3 µm at 3 x ØDCBN-DCBX and 3 µm direct
- Delivered with one stop screw

Machine side	Workpiece side	Designation	Dimensions in mm								TDZ	BHTA°	RL mm	**	RFID hole	Balancing	KG
			LPR	LB	CBDP	LSC	BD2	BD1	OAL	LFN-LF							
HSK-E50	3	E934356030355	55,0	29,0	31,0	13,0	20,0	15,0	80,0	25,5-42,0	M5x0.8	4,5	10,5	**	0	G2.5	0,50
	4	E934356030455	55,0	29,0	31,0	15,0	20,0	15,0	80,0	25,5-40,0	M5x0.8	4,5	10,5	**	0	G2.5	0,45
	6	E934356030655	55,0	29,0	32,0	22,0	27,0	21,0	80,0	24,5-33,0	M5x0.8	4,5	10,5	**	0	G2.5	0,50
	8	E934356030855	55,0	29,0	32,0	22,0	27,0	21,0	80,0	24,5-33,0	M6x1	4,5	10,5	**	0	G2.5	0,50
	10	E934356031060	60,0	34,0	37,0	31,0	32,0	24,0	85,0	24,5-29,0	M8x1	4,5	13,0	**	0	G2.5	0,60
	12	E934356031265	65,0	39,0	42,0	34,0	32,0	24,0	90,0	24,5-31,0	M10x1	4,5	13,0	**	0	G2.5	0,60
	12	E934356031290	90,0	64,0	47,5	34,0	32,0	24,0	115,0	44,0-56,0	M10x1	4,5	13,0	**	0	G2.5	0,70
	16	E934356031670	70,0	44,0	47,0	39,0	34,0	27,0	95,0	24,5-31,0	M12x1	4,5	14,0	**	0	G2.5	0,60

** Extra-short holder, without thread for a stop screw nor threaded holes for balancing screws and requiring a dedicated Easyshrink® cooling contact bush type '5603 extra-short', see page(s) 339. For Shrinkfit extensions, see page(s) 221

Accessories

For	Balancing screws
E934356031290	90ZQ01

Spare Parts

For	Stop screw
E934356031290	19BDR10165

Please check availability in current price and stock-list
 * For HSK sealing plugs, coolant tubes and tube spanners, see page(s) 294

EPB 5672 – High precision collet chucks

HSK-E



- Run-out 3 µm maximum at 3 x ∅DCBN-DCBX
- High transmittable torque
- High RPM suitable

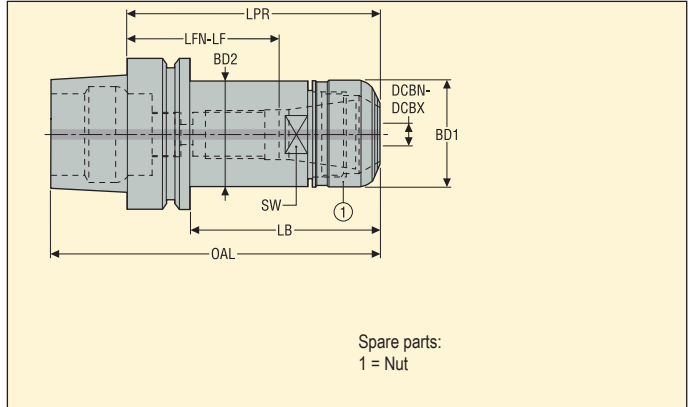

Machine side	Workpiece side	Designation	Chuck & Collet Size	Dimensions in mm								**	RFID hole	Balancing	KG
				LPR	BD2	BD1	OAL	LB	LFN-LF	SW***					
HSK-E25	0,5-10,0	E934056721655R	HP 16R	55,0	24,0	24,0	68,0	45,0	24,0-25,0	21,0	**	0	G2.5	0,14	
HSK-E32	0,5-7,0	E934156721150	HP 11	50,0	16,0	16,0	66,0	30,0	14,0-32,0	13,0	**	0	G2.5	0,2	
	0,5-10,0	E934156721660R	HP 16R	60,0	24,0	24,0	76,0	40,0	29,0-30,0	21,0	**	0	G2.5	0,24	
HSK-E40	0,5-7,0	E934256721150	HP 11	50,0	16,0	16,0	70,0	30,0	14,0-32,0	13,0	**	0	G2.5	0,3	
	0,5-10,0	E934256721660	HP 16	60,0	30,0	30,0	80,0	40,0	29,0-30,0	27,0	**	0	G2.5	0,36	
	0,5-10,0	E9342567216120	HP 16	120,0	30,0	30,0	140,0	100,0	89,0-90,0	27,0	**	0	G2.5	0,67	
	1,0-16,0	E934256722570	HP 25	70,0	40,0	40,0	90,0	50,0	14,0-32,0	36,0	**	0	G2.5	0,47	
HSK-E50	0,5-10,0	E934356721660	HP 16	60,0	30,0	30,0	85,0	34,0	29,0-30,0	27,0	**	0	G2.5	0,54	
	0,5-10,0	E9343567216120	HP 16	120,0	30,0	30,0	145,0	94,0	89,0-90,0	27,0	**	0	G2.5	0,83	
	1,0-16,0	E934356722570	HP 25	70,0	40,0	40,0	95,0	44,0	14,0-32,0	36,0	**	0	G2.5	0,67	

For ER HP collets type 5672, see page(s) 309-313. For chuck size HP 16R use the collet size ER HP 16, * A1 when using a stop screw

** Chuck without thread for stop screw, *** Flats for preventing the chuck from rotation during collet nut tightening, as HSK-E tapers are without driving slots

Accessories****

Spare Parts

For size	Socket	Spanner	Stop screw	Torque key	Nut
HP 11	03ER016	03BR016	19B5870812P1	03DYD010100	08B567211
HP 16	03ER030	03BR030	19B58711	03DYD010100	08B567216
HP 16R	03ER024	03BR024	19B58711	03DYD010100	08B567216R
HP 25	03ER040	03BR040	19B58718	03DYD020200	08B567225

Please check availability in current price and stock-list

**** When using a stop screw, its tapered contact onto the tool shank can increase the tool run-out defect, For tightening torques, see page(s) 41

For HSK sealing plugs, coolant tubes and tube spanners, see page(s) 294

EPB 5675 – ER collet chucks – ISO 15488

HSK-E



- Run-out 10 µm maximum at 3 x ØDCBN-DCBX

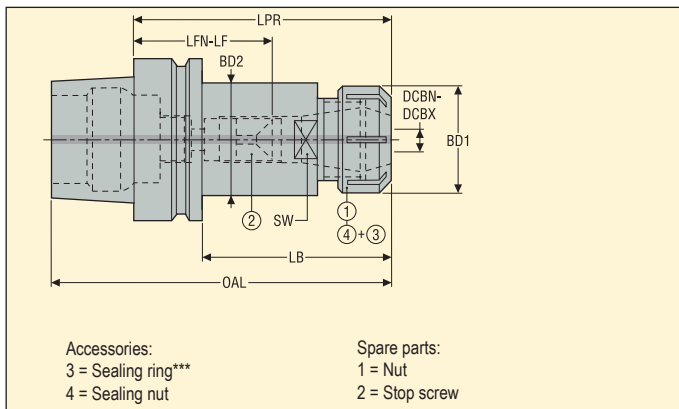

Machine side	Workpiece side	Designation	Chuck & Collet Size	Dimensions in mm							RFID hole	Balancing	KG
				LPR	BD2	BD1	OAL	LB	LFN-LF	SW**			
HSK-E32	0,5-10,0	E934156751660	ER 16	60,0	26,0	32,0	76,0	40,0	24,0-30,0	22,0	0	G2.5	0,25
	0,5-10,0	E934256751660	ER 16	60,0	32,0	32,0	80,0	40,0	26,0-30,0	27,0	0	G2.5	0,36
HSK-E40	1,0-16,0	E934256752570	ER 25	70,0	34,0	42,0	90,0	50,0	-	30,0	0	G2.5	0,45
	0,5-10,0	E9343567516100	ER 16	100,0	32,0	32,0	125,0	74,0	53,0-68,0	21,0	0	G2.5	0,76
HSK-E50	1,0-16,0	E9343567525100	ER 25	100,0	42,0	42,0	125,0	74,0	44,0-62,0	38,0	0	G2.5	0,97
	2,0-20,0	E9343567532100	ER 32	100,0	42,0	50,0	125,0	74,0	45,0-60,0	38,0	0	G2.5	0,98

For ER extensions and ER collets, see page(s) 222, 314-315

** Flats for preventing the chuck from rotation during collet nut tightening, as HSK-E tapers are without driving slots

Accessories***

For size	Seal nut	Socket	Spanner	Spanner 1	Torque key
ER 16	08B587516IC	03ER032	03B587516	03BR032	03DYD010100
ER 25	08B587525IC	03ER042	03B587525	03BR042	03DYD020200
ER 32	08B587532IC	03ER050	03B587532	03BR050	03DYD020200

Spare Parts

Nut	Stop screw
08B587516X	19B58711
08B587525X	19B58718
08B587532X	19B58722

Please check availability in current price and stock-list

* For HSK sealing plugs, coolant tubes and tube spanners, see page(s) 294

*** For ER sealing rings, see page(s) 320

EPB 5555/5556 – Steadyline®, vibration damping shell mill holders

DIN 69871-ADB



- With dynamic damping, ready to use
- Direct run-out 5 µm maximum
- With coolant supply channels through the spigot

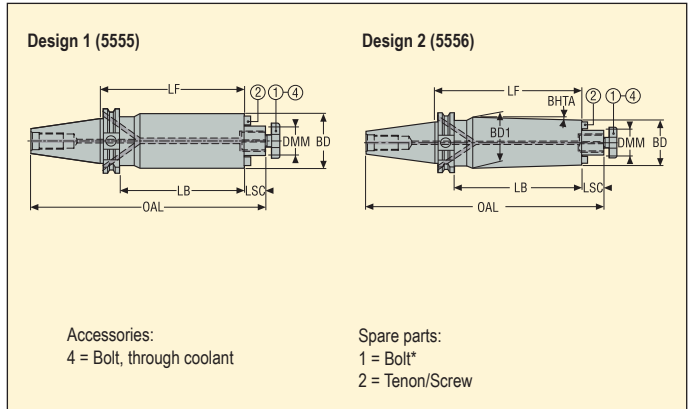

Machine side	Workpiece side	Designation	Dimensions in mm					Design	BHTA*	RFID hole	Balancing	KG	
			LF	BD	BD1	OAL	LB						LSC
DIN40 ADB	16	E3469555516160	160,0	38,0	38,0	245,4	141,0	17,0	1	–	1	PB	2,12
	22	E3469555522210	210,0	48,0	48,0	297,4	191,0	19,0	1	–	1	PB	3,74
	22	E3469555622260	260,0	48,0	63,2	347,4	241,0	19,0	2	1,9	1	PB	5,56
DIN50 ADB	22	E3471555522210	210,0	48,0	48,0	330,7	191,0	19,0	1	–	1	PB	5,36
	22	E3471555622260	260,0	48,0	66,0	380,7	241,0	19,0	2	2,0	1	PB	7,52
	27	E3471555527260	260,0	60,0	60,0	382,7	241,0	21,0	1	–	1	PB	8,52
	27	E3471555627320	320,0	60,0	79,5	442,7	301,0	21,0	2	1,7	1	PB	12,26
	32	E3471555532330	330,0	78,0	78,0	455,7	311,0	24,0	1	–	1	PB	14,96
	40	E3471555540350	350,0	89,0	89,0	475,7	331,0	27,0	1	–	1	PB	20,40

DMM 40, includes 4 threaded holes on the bearing face according to DIN 6357

Accessories

For Taper/ DMM	Bolt, through coolant	Spanner
DIN40/ 16	5801608L	5811608
DIN40/ 22	5802210L	5812210
DIN50/ 22	5802210L	5812210
DIN50/ 27	5802712L	5812712
DIN50/ 32	5803216L	5813216
DIN50/ 40	5804020L	5814020

Spare Parts*

For Taper/ DMM	Bolt	Plug	Screw	Tenon
DIN40/ 16	5801608	950A0406	950D0312	16C2080810A
DIN40/ 22	5802210	950A0406	950D0416	16C2101111
DIN50/ 22	5802210	950A0606	950D0416	16C2101111
DIN50/ 27	5802712	950A0606	950D0516	16C2121214A
DIN50/ 32	5803216	950A0606	950D0516	16C2141421A
DIN50/ 40	5804020	950A0606	950D0616	16C2161621A

Please check availability in current price and stock-list

* These centre bolts are similar to the original delivered ones: check if lengths are suitable for the milling cutters used, therefore see in the Operating instructions sheet delivered with the holders or in page(s) 30

EPB 5525/5524 – Shell mill holders, with through coolant channels

DIN 69871-ADB



- Direct run-out 5 µm maximum
- With coolant supply channels through the spigot

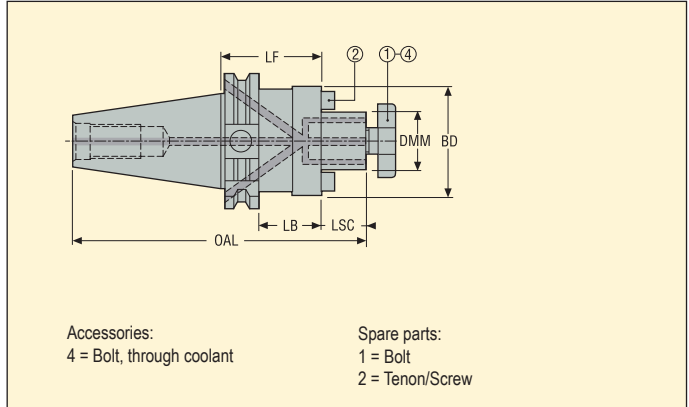

Machine side	Workpiece side	Designation	Dimensions in mm					*	RFID hole	Balancing	KG
			LF	BD	OAL	LB	LSC				
Taper	DMM mm										
DIN40 ADB	16	E346955251635	35,0	38,0	120,4	16,0	17,0		1	PB	0,94
	16	E3469552516100	100,0	38,0	185,4	81,0	17,0		1	PB	1,46
	22	E346955252235	35,0	48,0	122,4	16,0	19,0		1	PB	1,05
	22	E3469552522100	100,0	48,0	187,4	81,0	19,0		1	PB	1,90
	27	E346955252745	45,0	60,0	134,4	26,0	21,0	*	1	PB	1,30
	27	E3469552527100	100,0	60,0	189,4	81,0	21,0		1	PB	3,55
	32	E346955253250	50,0	78,0	142,4	–	24,0		1	PB	1,74
	40	E346955254050	50,0	89,0	145,4	–	27,0		1	PB	1,98
	27	E346955242735	35,0	48,0	124,4	16,0	21,0	*	1	PB	1,10

DMM 40, includes 4 threaded holes on the bearing face according to DIN 6357

* Diameter BD on type 5524 is smaller than on type 5525

Accessories

For DMM	Bolt, through coolant	Spanner
16	5801608L	5811608
22	5802210L	5812210
27/5524	5802712L	5812712
27100/5525	5802712L	5812712
2745/5525	5802712L	5812712
32	5803216L	5813216
40	5804020L	5814020

Spare Parts

For DMM	Bolt	Plug	Screw	Tenon
16	5801608	950A0406	950D0312	16C10810164
22	5802210	950A0406	951D0416	16C11012206
27/5524	5802712	950A0406	951D0512	16C127
27100/5525	5802712	950A0406	951D0516	16C11214243
2745/5525	5802712	950A0406	951D0512	16C127
32	5803216	950A0406	951D0516	16C2141421
40	5804020	950A0406	951D0616	16C2161621

Please check availability in current price and stock-list

EPB 5525/5524 – Shell mill holders, with through coolant channels

DIN 69871-ADB



- Direct run-out 5 µm maximum
- With coolant supply channels through the spigot

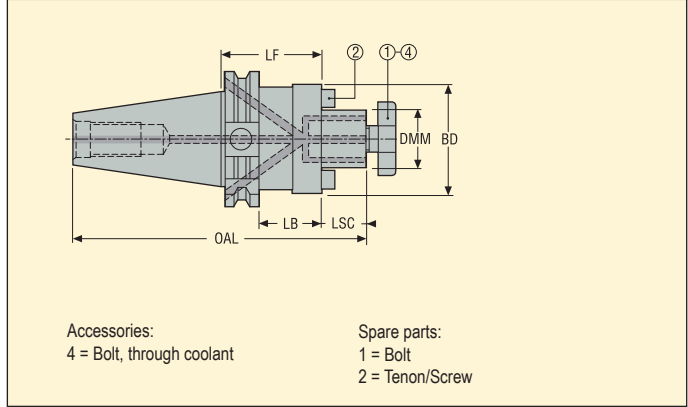

Machine side	Workpiece side	Designation	Dimensions in mm					RFID hole	Balancing	KG
			LF	BD	OAL	LB	LSC			
Taper	DMM mm									
DIN50 ADB	16	E3471552516100	100,0	38,0	218,7	81,0	17,0	1	PB	3,80
	22	E347155252235	35,0	48,0	155,7	16,0	19,0	1	PB	3,00
	22	E3471552522100	100,0	48,0	220,7	81,0	19,0	1	PB	4,75
	22	E347155252160	160,0	48,0	280,7	141,0	19,0	1	PB	5,15
	27	E347155252740	40,0	60,0	162,7	21,0	21,0	1	PB	3,20
	27	E3471552527100	100,0	60,0	222,7	81,0	21,0	1	PB	5,10
	27	E3471552527160	160,0	60,0	282,7	141,0	21,0	1	PB	6,10
	32	E347155253250	50,0	78,0	175,7	31,0	24,0	1	PB	4,00
	32	E3471552532100	100,0	78,0	225,7	81,0	24,0	1	PB	6,40
	32	E3471552532160	160,0	78,0	285,7	141,0	24,0	1	PB	8,40
	40	E347155254050	50,0	89,0	178,7	31,0	27,0	1	PB	4,10
	40	E3471552540100	100,0	89,0	228,7	81,0	27,0	1	PB	6,60
	40	E3471552540160	160,0	89,0	288,7	141,0	27,0	1	PB	8,70

DMM 40, includes 4 threaded holes on the bearing face according to DIN 6357

Accessories

For DMM	Bolt, through coolant	Spanner
16	5801608L	5811608
22	5802210L	5812210
27	5802712L	5812712
32	5803216L	5813216
40	5804020L	5814020

Spare Parts

For DMM	Bolt	Plug	Screw	Tenon
16	5801608	950A0606	950D0312	16C10810164
22	5802210	950A0606	950D0416	16C11012206
27	5802712	950A0606	951D0512	16C11214243
32	5803216	950A0606	951D0516	16C2141421
40	5804020	950A0606	951D0616	16C2161621

Please check availability in current price and stock-list

EPB 552 – Shell mill holders, small face – ISO 3937

DIN 69871-AD



- Direct run-out 5 µm maximum
- Small workpiece side diameter BD according to ISO 3937, suitable for Seco disc mill cutters Type B

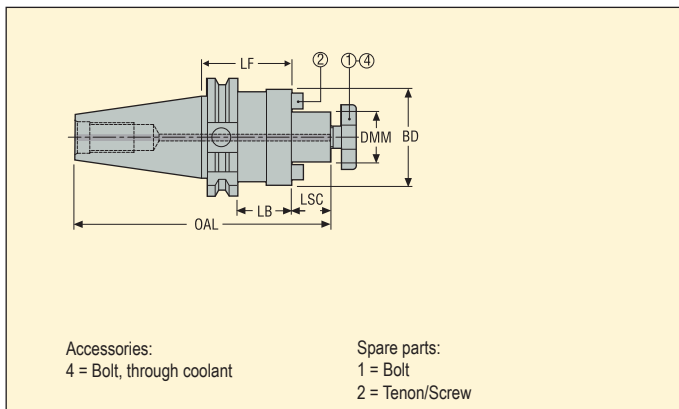

Machine side	Workpiece side	Designation	Dimensions in mm					RFID hole	Balancing	KG
			LF	BD	OAL	LB	LSC			
DIN40 AD	16	E44695521644	44,0	32,0	129,4	25,0	17,0	1	PB	0,95
	22	E44695522244	44,0	40,0	131,4	25,0	19,0	1	PB	1,09
	27	E44695522744	44,0	48,0	133,4	25,0	21,0	1	PB	1,24
	32	E44695523260	60,0	58,0	152,4	41,0	24,0	1	PB	1,72
DIN50 AD	22	E44715522244	44,0	40,0	164,7	25,0	19,0	1	PB	2,99
	27	E44715522744	44,0	48,0	166,7	25,0	21,0	1	PB	3,02
	32	E44715523244	44,0	58,0	169,7	25,0	24,0	1	PB	3,24
	40	E44715524044	44,0	70,0	172,7	25,0	27,0	1	PB	3,60

Accessories

Spare Parts

For DMM	Bolt, through coolant	Spanner	For DMM	Bolt	Screw	Tenon
16	5801608L	5811608	16	5801608	950D0308	16C116
22	5802210L	5812210	22	5802210	951D0410	16C122
27	5802712L	5812712	27	5802712	951D0512	16C127
32	5803216L	5813216	32	5803216	951D0514	16C132
40	5804020L	5814020	40	5804020	951D0616	16C140

Please check availability in current price and stock-list

EPB 5657 – Disc mill holders

DIN 69871-AD



- With adjustable slide rod
- Best suitable for Seco disc mill cutters Type A

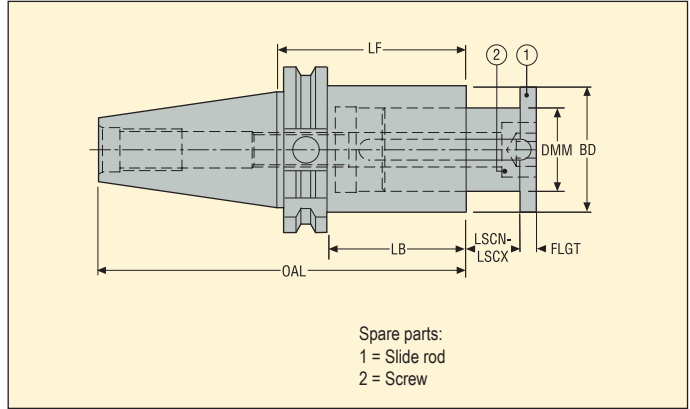

Machine side	Workpiece side	Designation	Dimensions in mm						RFID hole	Balancing	KG
			LF	BD	OAL	LB	LSCN-LSCX	FLGT			
DIN40 AD	22	E446956572265	65,0	35,0	133,4	45,9	0,0-12,0	4,0	1	PB	1,16
	27	E446956572765	65,0	42,0	133,4	45,9	0,0-15,0	5,0	1	PB	1,33
	32	E446956573290	90,0	48,0	158,4	70,9	0,0-24,0	6,0	1	PB	1,85
DIN50 AD	40	E4471565740100	100,0	58,0	201,7	80,9	0,0-30,0	7,0	1	PB	4,38
	50	E4471565750160	160,0	72,0	261,7	140,9	0,0-32,0	8,0	1	PB	7,06

Spare Parts

For DMM	Screw	Slide rod
22	19C565722	565722
27	19C565727	565727
32	950D1690	565732
40	19C565740	565740
50	19C565750	565750

Please check availability in current price and stock-list



- Direct run-out 3 µm maximum
- Weldon ØDCBN-DCBX 16, 20, 25, 32 and 40 with ground face (Seco-Weldon compatible)

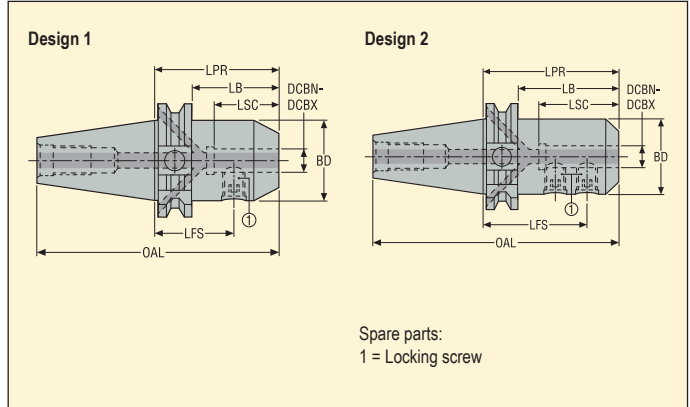

Machine side	Workpiece side	Designation	Dimensions in mm						Design	RFID hole	Balancing	KG
			LPR	LB	LSC	BD	OAL	LFS				
DIN50 ADB	6	E34715840663	63,0	43,9	27,0	25,0	164,75	45,5	1	1	PB	2,62
	6	E347158406120	120,0	101,0	27,0	25,0	221,7	102,5	1	1	PB	2,82
	8	E34715840863	63,0	43,9	30,0	28,0	164,75	45,5	1	1	PB	2,66
	8	E347158408120	120,0	100,9	30,0	28,0	221,75	102,5	1	1	PB	2,89
	10	E34715841063	63,0	43,9	36,0	35,0	164,75	43,5	1	1	PB	2,73
	10	E347158410120	120,0	100,9	36,0	35,0	221,75	100,5	1	1	PB	2,98
	12	E34715841263	63,0	43,9	43,0	42,0	164,75	41,0	1	1	PB	2,86
	12	E347158412120	120,0	120,0	43,0	42,0	221,7	98,0	1	1	PB	3,32
	14	E34715841463	63,0	43,9	43,0	44,0	164,75	41,0	1	1	PB	3,05
	16	E34715841663	63,0	43,9	46,0	48,0	164,75	39,5	1	1	PB	3,10
	16	E347158416120	120,0	100,9	46,0	48,0	221,75	96,5	1	1	PB	3,60
	18	E34715841863	63,0	43,9	46,0	50,0	164,75	39,5	1	1	PB	3,15
	20	E34715842063	63,0	43,9	48,0	52,0	164,75	38,5	1	1	PB	3,03
	20	E347158420120	120,0	100,9	48,0	52,0	221,75	95,5	1	1	PB	4,05
	25	E34715842580	80,0	61,0	54,0	65,0	181,7	56,5	2	1	PB	3,66
	25	E347158425120	120,0	100,9	54,0	65,0	221,75	96,5	2	1	PB	4,68
	32	E347158432100	100,0	81,0	58,0	72,0	201,7	76,5	2	1	PB	4,46
	40	E347158440120	120,0	101,0	68,0	80,0	221,7	90,5	2	1	PB	5,70
50	E347158450130	130,0	110,9	78,0	100,0	231,7	95,5	2	1	PB	7,19	

Spare Parts

For DCBN-DCBX	Locking screw	Plug
6	951C0610	950A0606
8	951C0810	950A0606
10	951C1012	950A0606
12-14	951C1216	950A0606
16-18	951C1416	950A0606
20	951C1616	950A0606
25	951C1820	950A0606
32-40	951C2020	950A0606
50	951C2425	950A0606

Please check availability in current price and stock-list

EPB 5603 – Shrinkfit holders, DIN type

DIN 69871-ADB



- Run-out maximum: 3 µm at 3 x ØDCBN-DCBX and 3 µm direct
- Delivered with one stop screw

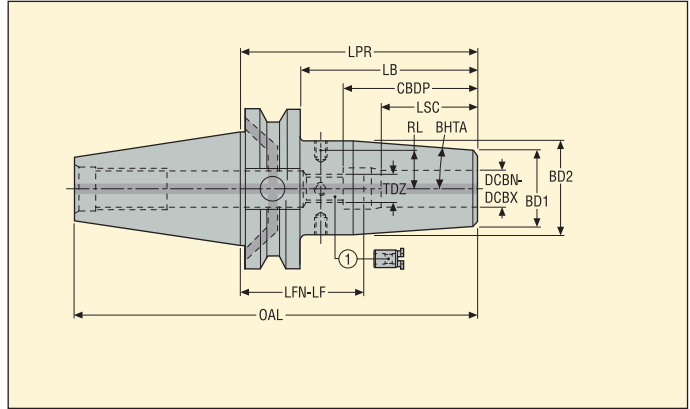

Machine side	Workpiece side	Designation	Dimensions in mm								TDZ	BHTA°	RL mm	RFID hole	Balancing	KG
			LPR	LB	CBDP	LSC	BD2	BD1	OAL	LFN-LF						
DIN40 ADB	6	E346956030680	80,0	60,9	37,5	22,0	27,0	21,0	148,4	44,0-58,0	M5x0.8	4,5	10,5	1	G2.5	1,01
	6	E3469560306120	120,0	100,9	37,5	22,0	27,0	21,0	188,4	84,0-98,0	M5x0.8	4,5	10,5	1	G2.5	1,18
	6	E3469560306160	160,0	140,9	37,5	22,0	27,0	21,0	228,4	124,0-138,0	M5x0.8	4,5	10,5	1	G2.5	1,40
	8	E346956030880	80,0	60,9	37,5	26,0	27,0	21,0	148,4	44,0-54,0	M6x1	4,5	10,5	1	G2.5	1,00
	8	E3469560308120	120,0	100,9	37,5	26,0	27,0	21,0	188,4	84,0-94,0	M6x1	4,5	10,5	1	G2.5	1,20
	8	E3469560308160	160,0	140,9	37,5	26,0	27,0	21,0	228,4	124,0-134,0	M6x1	4,5	10,5	1	G2.5	1,32
	10	E346956031080	80,0	60,9	42,5	31,0	32,0	24,0	148,4	39,0-49,0	M8x1	4,5	13,0	1	G2.5	1,06
	10	E3469560310120	120,0	100,9	42,5	31,0	32,0	24,0	188,4	79,0-89,0	M8x1	4,5	13,0	1	G2.5	1,30
	10	E3469560310160	160,0	140,9	42,5	31,0	32,0	24,0	228,4	119,0-129,0	M8x1	4,5	13,0	1	G2.5	1,52
	12	E346956031280	80,0	60,9	47,5	34,0	32,0	24,0	148,4	34,0-46,0	M10x1	4,5	13,0	1	G2.5	1,04
	12	E3469560312120	120,0	100,9	47,5	34,0	32,0	24,0	188,4	74,0-86,0	M10x1	4,5	13,0	1	G2.5	1,27
	12	E3469560312160	160,0	140,9	47,5	34,0	32,0	24,0	228,4	114,0-126,0	M10x1	4,5	13,0	1	G2.5	1,50
	14	E346956031480	80,0	60,9	47,5	34,0	34,0	27,0	148,4	34,0-46,0	M10x1	4,5	14,0	1	G2.5	1,09
	14	E3469560314120	120,0	100,9	47,5	34,0	34,0	27,0	188,4	74,0-86,0	M10x1	4,5	14,0	1	G2.5	1,35
	16	E346956031680	80,0	60,9	50,5	39,0	34,0	27,0	148,4	31,0-41,0	M12x1	4,5	14,0	1	G2.5	1,06
	16	E3469560316120	120,0	100,9	50,5	39,0	34,0	27,0	188,4	71,0-81,0	M12x1	4,5	14,0	1	G2.5	1,40
	16	E3469560316160	160,0	140,9	50,5	39,0	34,0	27,0	228,4	111,0-121,0	M12x1	4,5	14,0	1	G2.5	1,60
	18	E346956031880	80,0	60,9	50,5	39,0	42,0	33,0	148,4	31,0-41,0	M12x1	4,5	18,0	1	G2.5	1,30
20	E346956032080	80,0	60,9	52,5	41,0	42,0	33,0	148,4	29,0-39,0	M16x1	4,5	18,0	1	G2.5	1,15	
20	E3469560320120	120,0	100,9	52,5	41,0	42,0	33,0	188,4	69,0-79,0	M16x1	4,5	18,0	1	G2.5	1,60	
25	E3469560325100	100,0	80,9	58,5	47,0	53,0	44,0	168,4	43,0-53,0	M16x1	4,5	23,5	1	G2.5	1,70	

For Shrinkfit extensions, see page(s) 221

Accessories

For DCBN-DCBX	Balancing screws
6	90ZQ01
8	90ZQ01
10	90ZQ01
12-14	90ZQ01
16-18	90ZQ01
20-25	90ZQ01

Spare Parts

For DCBN-DCBX	Plug	Stop screw
6	950A0406	19BDR05165
8	950A0406	19BDR06165
10	950A0406	19BDR08165
12-14	950A0406	19BDR10165
16-18	950A0406	19BDR12165
20-25	950A0406	19BDR16165

Please check availability in current price and stock-list

EPB 5603 – Shrinkfit holders, DIN type

DIN 69871-ADB



- Run-out maximum: 3 µm at 3 x ØDCBN-DCBX and 3 µm direct
- Delivered with one stop screw

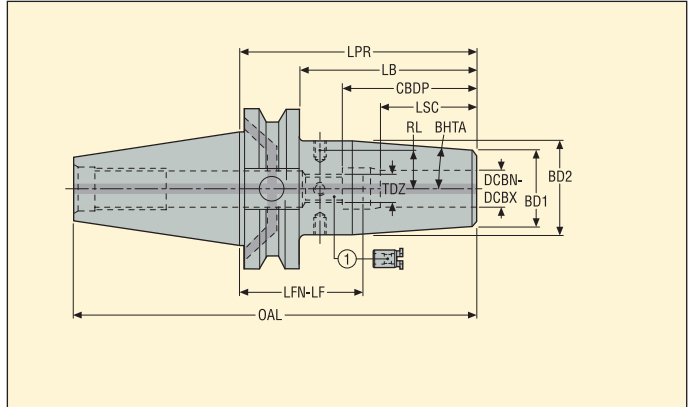

Machine side	Workpiece side	Designation	Dimensions in mm								TDZ	BHTA°	RL mm	RFID hole	Balancing	KG
			LPR	LB	CBDP	LSC	BD2	BD1	OAL	LFN-LF						
DIN50 ADB	6	E347156030680	80,0	60,9	37,5	22,0	27,0	21,0	181,8	44,0-58,0	M5x0,8	4,5	10,5	1	G2.5	2,79
	6	E3471560306160	160,0	140,9	37,5	22,0	27,0	21,0	261,8	124,0-138,0	M5x0,8	4,5	10,5	1	G2.5	3,05
	8	E347156030880	80,0	60,9	37,5	26,0	27,0	21,0	181,8	44,0-54,0	M6x1	4,5	10,5	1	G2.5	2,77
	8	E3471560308160	160,0	140,9	37,5	26,0	27,0	21,0	261,8	124,0-134,0	M6x1	4,5	10,5	1	G2.5	3,04
	10	E347156031080	80,0	60,9	42,5	31,0	32,0	24,0	181,8	39,0-49,0	M8x1	4,5	13,0	1	G2.5	2,83
	10	E3471560310160	160,0	140,9	42,5	31,0	32,0	24,0	261,8	119,0-129,0	M8x1	4,5	13,0	1	G2.5	3,27
	12	E347156031280	80,0	60,9	47,5	34,0	32,0	24,0	181,8	34,0-46,0	M10x1	4,5	13,0	1	G2.5	2,81
	12	E3471560312160	160,0	140,9	47,5	34,0	32,0	24,0	261,8	114,0-126,0	M10x1	4,5	13,0	1	G2.5	3,25
	14	E347156031480	80,0	60,9	47,5	34,0	34,0	27,0	181,8	34,0-46,0	M10x1	4,5	14,0	1	G2.5	2,86
	16	E347156031680	80,0	60,9	50,5	39,0	34,0	27,0	181,8	31,0-41,0	M12x1	4,5	14,0	1	G2.5	2,83
	16	E3471560316160	160,0	140,9	50,5	39,0	34,0	27,0	261,8	111,0-121,0	M12x1	4,5	14,0	1	G2.5	3,40
	18	E347156031880	80,0	60,9	50,5	39,0	42,0	33,0	181,8	31,0-41,0	M12x1	4,5	18,0	1	G2.5	3,00
	20	E347156032080	80,0	60,9	52,5	41,0	42,0	33,0	181,8	29,0-39,0	M16x1	4,5	18,0	1	G2.5	2,92
	20	E3471560320160	160,0	140,9	52,5	41,0	42,0	33,0	261,8	109,0-119,0	M16x1	4,5	18,0	1	G2.5	3,70
	25	E347156032590	90,0	70,9	58,5	47,0	53,0	44,0	191,8	33,0-43,0	M16x1	4,5	23,5	1	G2.5	3,35
	25	E3471560325160	160,0	140,9	58,5	47,0	53,0	44,0	261,8	103,0-113,0	M16x1	4,5	23,5	1	G2.5	4,47
	32	E347156033290	90,0	70,9	62,5	51,0	53,0	44,0	191,8	29,0-39,0	M16x1	4,5	23,5	1	G2.5	3,18

For Shrinkfit extensions, see page(s) 221

Accessories

For DCBN-DCBX	Balancing screws
6	90ZQ01
8	90ZQ01
10	90ZQ01
12-14	90ZQ01
16-18	90ZQ01
20-32	90ZQ01

Spare Parts

For DCBN-DCBX	Plug	Stop screw
6	950A0606	19BDR05165
8	950A0606	19BDR06165
10	950A0606	19BDR08165
12-14	950A0606	19BDR10165
16-18	950A0606	19BDR12165
20-32	950A0606	19BDR16165

Please check availability in current price and stock-list

EPB 5600 – Shrinkfit holders, reinforced

DIN 69871-ADB



- Reinforced design with wider front and tapered body
- Run-out maximum: 3 µm at 3 x ØDCBN-DCBX and 3 µm direct
- With coolant supply channels towards the tool (plugged)
- Delivered with one stop screw

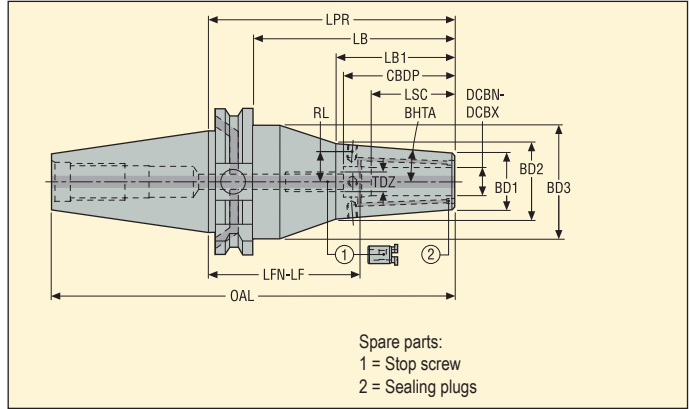

Machine side	Workpiece side	Designation	Dimensions in mm										TDZ	BHTA°	**	RL mm	RFID hole	Balancing	KG
			LPR*	LB	LB1	CBDP	LSC	BD3	BD2	BD1	OAL	LFN-LF							
DIN40 ADB	10	E346956001065	65,0	45,9	46,0	42,5	31,0	-	35,2	27,0	133,4	24,0-34,0	M8x1	4,5		13,5	1	G2.5	1,05
	10	E3469560010130	130,0	110,9	52,0	42,5	31,0	49,5	35,2	27,0	198,4	89,0-99,0	M8x1	4,5		13,5	1	G2.5	1,80
	12	E346956001265	65,0	45,9	46,0	47,5	34,0	-	35,2	27,0	133,4	19,0-31,0	M10x1	4,5		13,5	1	G2.5	1,05
	12	E3469560012130	130,0	110,9	52,0	47,5	34,0	49,5	35,2	27,0	198,4	84,0-96,0	M10x1	4,5		13,5	1	G2.5	1,75
	16	E346956001665	65,0	45,9	46,0	50,5	39,0	-	42,1	33,0	133,4	16,0-26,0	M12x1	4,5		17,0	1	G2.5	1,10
	16	E3469560016130	130,0	110,9	58,0	50,5	39,0	49,5	42,1	33,0	198,4	81,0-91,0	M12x1	4,5		17,0	1	G2.5	1,90
	20	E346956002065	65,0	45,9	46,0	52,5	41,0	49,5	53,1	44,0	133,4	14,0-24,0	M16x1	4,5	**	21,5	1	G2.5	1,27
	20	E3469560020130	130,0	110,9	111,0	52,5	41,0	49,5	53,1	44,0	198,4	79,0-89,0	M16x1	4,5		21,5	1	G2.5	2,36

* E346956001665, E346956002065, E346956002575: Extra-short holders requiring a dedicated Easyshrink® cooling contact bush type "5600 extra short", see page(s) 339, ** Holder without threaded holes for balancing screw

Accessories

For DCBN-DCBX	Balancing screws
10	90ZQ01
12	90ZQ01
16	90ZQ01
20-25	90ZQ01

Spare Parts

For DCBN-DCBX	Plug	Sealing plugs	Stop screw
10	950A0406	90AI03	19BDR08165
12	950A0406	90AI03	19BDR10165
16	950A0406	90AI03	19BDR12165
20-25	950A0406	90AI04	19BDR16165

Please check availability in current price and stock-list

EPB 5600P Safe-Lock™ – Shrinkfit holders, reinforced and with tool pull-out protection

DIN 69871-ADB



- With Safe-Lock™ tool pull-out protection system
- Reinforced design of EPB 5600
- Run-out maximum: 3 μm at 3 x ØDCBN-DCBX and 3 μm direct
- With coolant supply channels towards the tool (plugged)
- Delivered with one stop screw fitted

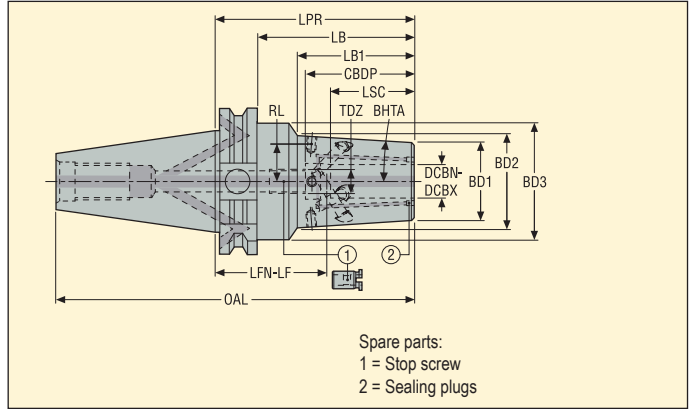

Machine side	Workpiece side	Designation	Dimensions in mm										TDZ	BHTA°	**	RL mm	RFID hole	Balancing	KG
			LPR*	LB	LB1	CBDP	LSC	BD3	BD2	BD1	OAL	LFN-LF							
DIN40 ADB	12	E346956001265P	65,0	45,9	–	47,5	34,0	–	34,3	27,0	133,4	19,0-27,5	M10x1	4,5		13,5	1	G2.5	1,10
	16	E346956001665P	65,0	45,9	–	50,5	39,0	–	40,3	33,0	133,4	16,0-24,0	M12x1	4,5		17,0	1	G2.5	1,10
	20	E346956002065P	65,0	45,9	–	52,5	41,0	49,5	–	44,0	133,4	14,0-22,0	M16x1	4,5	**	–	1	G2.5	1,30
	25	E346956002575P	75,0	55,9	40,0	58,5	47,0	49,5	57,1	48,0	143,4	18,0-26,0	M16x1	4,5	**	–	1	G2.5	1,50
DIN50 ADB	12	E347156001280P	80,0	60,9	–	47,5	34,0	–	36,6	27,0	181,8	34,0-42,5	M10x1	4,5		13,5	1	G2.5	3,00
	16	E347156001680P	80,0	60,9	–	50,5	39,0	–	42,6	33,0	181,8	31,0-39,0	M12x1	4,5		17,0	1	G2.5	3,10
	20	E347156002080P	80,0	60,9	–	52,5	41,0	–	53,6	44,0	181,8	29,0-39,0	M16x1	4,5		21,5	1	G2.5	3,40
	25	E347156002590P	90,0	70,9	–	58,5	47,0	–	61,2	48,0	191,8	33,0-41,0	M16x1	4,5		25,0	1	G2.5	3,70
	32	E347156003290P	90,0	70,9	–	62,5	51,0	–	61,2	48,0	191,8	29,0-39,0	M16x1	4,5		25,0	1	G2.5	3,50

* E346956001665P, E346956002065P, E346956002575P and E347156002080P: Extra-short holders requiring a dedicated Easyshrink® cooling contact bush type "5600 extra short", see page(s) 339, ** Holder without threaded holes for balancing screw

Accessories

For Taper/ DCBN-DCBX	Balancing screws
DIN40/ 12-16	90ZQ01
DIN40/ 20-32	90ZQ01
DIN50/ 12-16	90ZQ01
DIN50/ 20-32	90ZQ01

Spare Parts

For Taper/ DCBN-DCBX	Plug	Sealing plugs	Stop screw
DIN40/ 12-16	950A0406	90AI03	–
DIN40/ 20-32	950A0406	90AI04	19BDR16165
DIN50/ 12-16	950A0606	90AI03	–
DIN50/ 20-32	950A0606	90AI04	19BDR16165

Please check availability in current price and stock-list

(-) For DCBN-DCBX 12 and 16 mm, stop screw not removable/replaceable by the user, please request a repair process

EPB 5801 – Shrinkfit holders, Mould and Die type

DIN/ CAT (Combined)

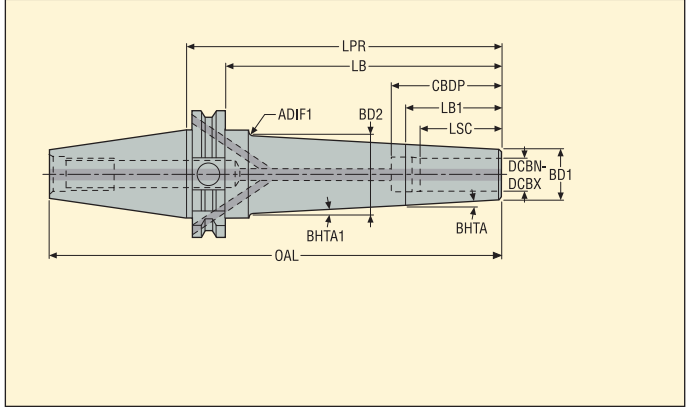

- Run-out maximum: 3 µm at 3 x ØDCBN-DCBX and 3 µm direct

Machine side	Workpiece side	Designation	Dimensions in mm										RFID hole	Balancing	KG	
			LPR	LB	CBDP	LB1	LSC	BD1	BD2	OAL	BHTA°	BHTA1°				ADIF1
Taper	DCBN-DCBX mm															
DIN40 ADB/ CAT40	3	E347658010380	80,0	61,0	–	25,0	13,0	9,0	15,00	148,4	3,0	5,0	7	1	G2.5	1,00
	3	E3476580103140	140,0	120,0	–	25,0	13,0	9,0	26,00	208,4	3,0	5,0	7	1	G2.5	1,12
	4	E347658010480	80,0	61,0	–	25,0	15,0	10,0	16,00	148,4	3,0	5,0	7	1	G2.5	1,00
	4	E3476580104140	140,0	120,0	–	25,0	15,0	10,0	27,00	208,4	3,0	5,0	7	1	G2.5	1,13
	6	E347658010680	80,0	61,0	40,0	61,0	26,0	12,0	17,00	148,4	3,0	3,0	7	1	G2.5	1,02
	6	E3476580106140	140,0	120,0	40,0	32,0	26,0	12,0	30,00	208,4	3,0	5,0	7	1	G2.5	1,17
	8	E347658010880	80,0	61,0	44,0	61,0	30,0	16,0	21,00	148,4	3,0	3,0	7	1	G2.5	1,04
	8	E3476580108140	140,0	120,0	44,0	36,0	30,0	16,0	32,00	208,4	3,0	5,0	6	1	G2.5	1,23
	10	E347658011080	80,0	61,0	45,0	61,0	32,0	18,0	23,00	148,4	3,0	3,0	7	1	G2.5	1,05
	10	E3476580110160	160,0	140,0	45,0	38,0	32,0	18,0	38,00	228,4	3,0	5,0	2,5	1	G2.5	1,44
	12	E347658011280	80,0	61,0	46,0	61,0	34,0	20,0	25,00	148,4	3,0	3,0	7	1	G2.5	1,06

Spare Parts

For Taper	Plug
DIN40	950A0406

Please check availability in current price and stock-list
For Shrinkfit extensions, see page(s) 221

EPB 5672 – High precision collet chucks

DIN 69871-ADB

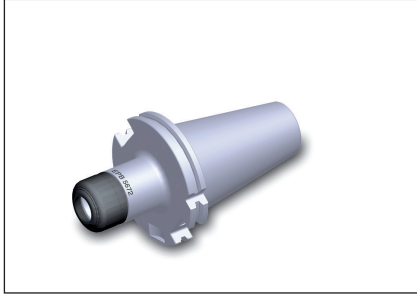

- Run-out 3 µm maximum at 3 x ØDCBN-DCBX
- High transmittable torque
- High RPM suitable

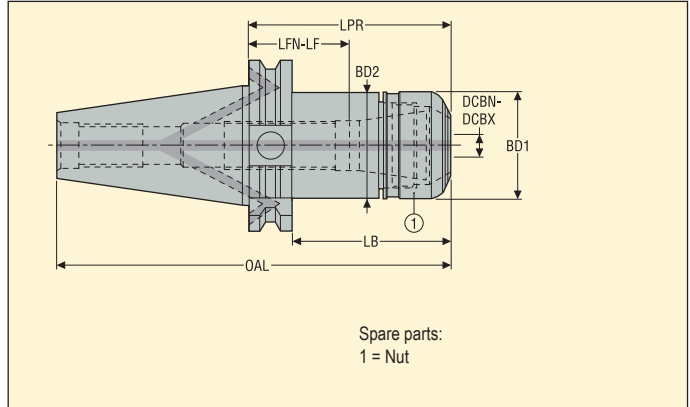

Machine side	Workpiece side	Capacity DCBN-DCBX mm	Designation	Chuck & Collet Size	Dimensions in mm					RFID hole	Balancing	KG
					LPR	BD1	BD2	OAL	LB			
DIN40 ADB	0,5-10,0	E346956721670	HP 16	70,0	30,0	30,0	138,4	50,9	39,0-40,0	1	G2.5	1,0
	0,5-10,0	E3469567216130	HP 16	130,0	30,0	30,0	198,4	110,9	99,0-100,0	1	G2.5	1,28
	1,0-16,0	E346956722570	HP 25	70,0	40,0	40,0	138,4	50,9	14,0-32,0	1	G2.5	1,1
	1,0-16,0	E3469567225160	HP 25	160,0	40,0	40,0	228,4	140,9	104,0-122,0	1	G2.5	1,86
	2,0-20,0	E346956723270	HP 32	70,0	50,0	50,0	138,4	50,9	14,0-18,0	1	G2.5	1,24
DIN50 ADB	1,0-16,0	E347156722580	HP 25	80,0	40,0	40,0	181,75	60,9	24,0-42,0	1	G2.5	2,96
	2,0-20,0	E347156723280	HP 32	80,0	50,0	50,0	181,75	60,9	24,0-28,0	1	G2.5	3,15

For ER HP collets type 5672, see page(s) 309-313

* LFN-LF setting length onto stop screw when possible, or total available setting length for chucks without thread for stop screw

Accessories**

For Taper/size	Socket	Spanner	Stop screw	Torque key
DIN40/ HP16	03ER030	03BR030	19B58711	03DYD010100
DIN40/ HP25	03ER040	03BR040	19B58718	03DYD020200
DIN40/ HP32	03ER050	03BR050	19B58722	03DYD020200
DIN50/ HP25	03ER040	03BR040	19B58718	03DYD020200
DIN50/ HP32	03ER050	03BR050	19B58722	03DYD020200

Spare Parts

For Taper/size	Nut	Plug
DIN40/ HP16	08B567216	950A0406
DIN40/ HP25	08B567225	950A0406
DIN40/ HP32	08B567232	950A0406
DIN50/ HP25	08B567225	950A0606
DIN50/ HP32	08B567232	950A0606

Please check availability in current price and stock-list

** When using a stop screw, its tapered contact onto the tool shank can increase the tool run-out defect

For tightening torques, see page(s) 41

EPB 5834 – Hydraulic chucks

DIN 69871-ADB



- Run-out 3 µm maximum at 3 x ∅DCBN-DCBX

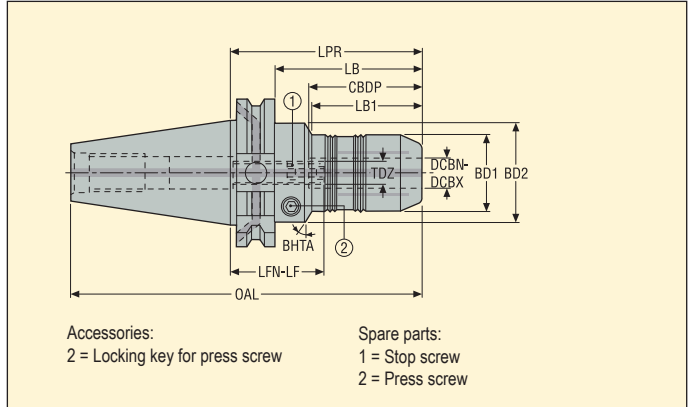

Machine side	Workpiece side	Designation	Dimensions in mm									TDZ	BHTA°	RFID hole	Balancing	KG
			LPR	LB	CBDP	LB1	BD2	BD1	OAL	LFN-LF						
DIN40 ADB	6	E346958340680	80,0	61,0	38,0	23,0	50,0	26,0	148,4	42,0-52,0	M5	30,0	1	G6.3	1,36	
	8	E346958340880	80,0	61,0	38,0	24,0	50,0	28,0	148,4	42,0-52,0	M5	30,0	1	G6.3	1,36	
	10	E346958341080	80,0	61,0	42,0	34,0	50,0	30,0	148,4	38,0-48,0	M8	30,0	1	G6.3	1,27	
	12	E346958341280	80,0	61,0	47,0	40,0	50,0	32,0	148,4	33,0-43,0	M10	30,0	1	G6.3	1,32	
	14	E346958341480	80,0	61,0	47,0	40,0	50,0	34,0	148,4	33,0-43,0	M10	30,0	1	G6.3	1,30	
	16	E346958341680	80,0	61,0	50,0	46,0	50,0	38,0	148,4	30,0-40,0	M10	30,0	1	G6.3	1,40	
	20	E346958342080	80,0	61,0	52,0	47,0	50,0	42,0	148,4	28,0-38,0	M10	30,0	1	G6.3	1,40	
	25	E346958342595	95,0	75,9	58,0	60,0	50,0	58,0	163,4	37,0-47,0	M10	60,0	1	G6.3	1,93	
DIN50 ADB	12	E347158341280	80,0	61,0	47,0	40,0	50,0	32,0	181,7	33,0-43,0	M10	30,0	1	G6.3	5,00	
	20	E347158342080	80,0	61,0	52,0	47,0	50,0	42,0	181,7	28,0-38,0	M10	30,0	1	G6.3	5,40	
	25	E347158342595	95,0	75,9	58,0	50,0	70,0	58,0	196,7	37,0-47,0	M10	30,0	1	G6.3	3,98	
	32	E347158343290	90,0	71,0	63,0	50,0	70,0	64,0	191,7	27,0-37,0	M10	30,0	1	G6.3	5,70	

For reduction sleeves and control gauges, see page(s) 307-308

Accessories

Spare Parts

For Taper/ DCBN-DCBX	Locking key	For Taper/ DCBN-DCBX	Plug	Press screw	Stop screw
DIN40/ 6-8	H04-4	DIN40/ 6-8	950A0406	950AF0810008	19LS0520A
DIN40/ 10	H04-4	DIN40/ 10	950A0406	950AF0810008	19LS0820A
DIN40/ 12	H04-4	DIN40/ 12	950A0406	950AF0810008	19LS1020A
DIN40/ 14-25	H04-4	DIN40/ 14-25	950A0406	950AF1010010	19LS1020A
DIN50/ 12	H04-4	DIN50/ 12	950A0606	950AF0810008	19LS1020A
DIN50/ 20-32	H04-4	DIN50/ 20-32	950A0606	950AF1010010	19LS1020A

Please check availability in current price and stock-list

EPB 5835 – Hydraulic chucks, strong

DIN 69871-ADB



- Run-out 4 µm maximum at 3 x ØDCBN-DCBX

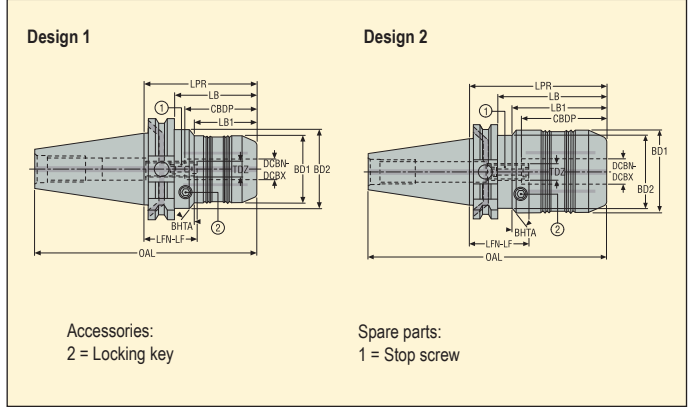

Machine side	Workpiece side	Designation	Dimensions in mm								TDZ	Design	BHTA°	RFID hole	Balancing	KG
			LPR	LB	CBDP	LB1	BD2	BD1	OAL	LFN-LF						
DIN40 ADB	12	E346958351275	75,0	56,0	47,0	–	–	48,0	143,4	28,0-38,0	M10	1	–	1	PB	1,49
	16	E346958351680	80,0	60,9	50,0	45,0	61,5	55,0	148,4	30,0-40,0	M10	1	30,0	1	PB	1,80
	20	E346958352080	80,0	61,0	52,0	45,0	49,5	62,5	148,4	28,0-38,0	M10	2	0,0	1	PB	1,98
DIN50 ADB	20	E347158352080	80,0	61,0	52,0	–	–	62,5	181,7	28,0-38,0	M10	1	–	1	PB	4,00
	25	E347158352580	80,0	60,9	58,0	–	–	71,0	141,8	22,0-32,0	M10	1	–	1	PB	4,10
	32	E347158353280	80,0	61,0	63,0	–	–	80,0	181,7	17,0-27,0	M10	1	–	1	PB	4,53

For reduction sleeves and control gauges, see page(s) 307-308

Accessories

For Taper	Locking key
DIN40	03HXL06
DIN50	03HXL06

Spare Parts

For Taper	Plug	Stop screw
DIN40	950A0406	19LS1016A
DIN50	950A0606	19LS1016A

Please check availability in current price and stock-list



- Run-out 10 µm maximum at 3 x ØDCBN-DCBX

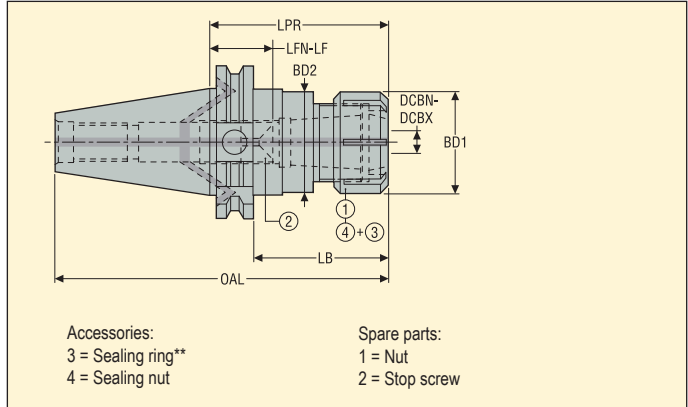

Machine side	Workpiece side	Capacity DCBN-DCBX mm	Designation	Chuck & Collet Size	Dimensions in mm					*	RFID hole	Balancing	KG
					LPR	BD2	BD1	OAL	LB				
DIN40 ADB	0,5-10,0	E346956751670	ER 16	70,0	32,0	32,0	138,4	51,0	22,0-38,0		1	G2.5	0,99
	0,5-10,0	E3469567516120	ER 16	120,0	32,0	32,0	188,4	101,0	72,0-88,0		1	G2.5	1,29
	1,0-16,0	E346956752570	ER 25	70,0	42,0	42,0	138,4	51,0	11,0-32,0		1	G2.5	1,1
	1,0-16,0	E3469567525120	ER 25	120,0	42,0	42,0	188,4	101,0	51,0-82,0		1	G2.5	1,61
	2,0-20,0	E346956753270	ER 32	70,0	50,0	50,0	138,4	51,0	12,0-30,0		1	G2.5	1,17
	2,0-20,0	E3469567532120	ER 32	120,0	50,0	50,0	188,4	101,0	52,0-80,0		1	G2.5	1,86
	3,0-26,0	E446956754070	ER 40*	70,0	50,0	63,0	138,4	51,0	0,0-25,0	*	1	G2.5	1,2
DIN50 ADB	0,5-10,0	E3471567516120	ER 16	120,0	32,0	32,0	221,7	101,0	72,0-88,0		1	G2.5	2,97
	1,0-16,0	E347156752590	ER 25	90,0	42,0	42,0	191,7	71,0	21,0-52,0		1	G2.5	3,02
	2,0-20,0	E347156753290	ER 32	90,0	50,0	50,0	191,7	71,0	22,0-50,0		1	G2.5	3,2
	2,0-20,0	E3471567532150	ER 32	150,0	50,0	50,0	251,7	131,0	82,0-110,0		1	G2.5	3,98
	3,0-26,0	E3471567540100	ER 40	100,0	63,0	63,0	201,7	81,0	28,0-55,0		1	G2.5	3,76

For ER extensions and ER collets, see page(s) 222, 314-315

* Chuck ER40/A70 is type AD (E4469) without flange coolant through, instead type ADB (E3469)

Accessories**

For Taper/size	Seal nut	Socket	Spanner	Spanner 1	Torque key
DIN40/ ER16	08B587516IC	03ER032	03B587516	03BR032	03DYD010100
DIN40/ ER25	08B587525IC	03ER042	03B587525	03BR042	03DYD020200
DIN40/ ER32	08B587532IC	03ER050	03B587532	03BR050	03DYD020200
DIN40/ ER40*	08B587540IC	03ER063	03B587540	03BR063	03DYD020200
DIN50/ ER16	08B587516IC	03ER032	03B587516	03BR032	03DYD010100
DIN50/ ER25	08B587525IC	03ER042	03B587525	03BR042	03DYD020200
DIN50/ ER32	08B587532IC	03ER050	03B587532	03BR050	03DYD020200
DIN50/ ER40	08B587540IC	03ER063	03B587540	03BR063	03DYD020200

Spare Parts

Nut	Plug	Stop screw
08B587516X	950A0406	19B58711
08B587525X	950A0406	19B58718
08B587532X	950A0406	19B58722
08B587540X	-	19B58730
08B587516X	950A0606	19B58711
08B587525X	950A0606	19B58718
08B587532X	950A0606	19B58722
08B587540X	950A0606	19B58730

Please check availability in current price and stock-list

** For ER sealing rings, see page(s) 320

EPB 5873 – OZ collet chucks – DIN 6388

DIN 69871-ADB



- Run-out 15 µm maximum at 3 x ØDCBN-DCBX

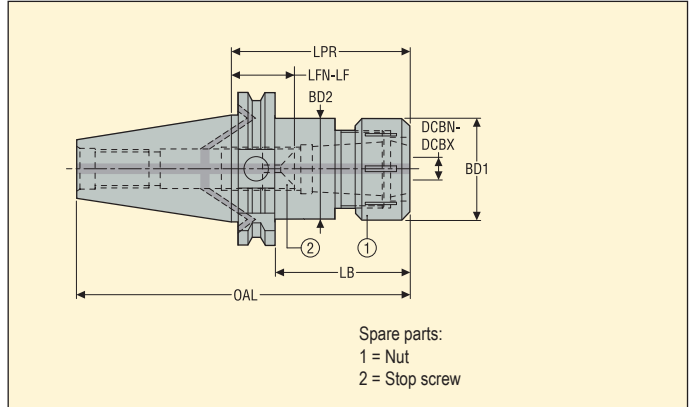

Machine side	Workpiece side	Capacity DCBN-DCBX mm	Designation	Chuck & Collet Size	Dimensions in mm					RFID hole	Balancing	KG
					LPR	BD1	BD2	OAL	LB			
DIN40 ADB	4,0-32,0	E346958733290	OZ 32	90,0	72,0	50,0	158,4	71,0	15,0-25,0	1	PB	1,72
DIN50 ADB	4,0-32,0	E347158733273	OZ 32	73,0	72,0	72,0	174,7	54,0	0,0-8,0	1	PB	3,28

For OZ collets, see page(s) 323

Accessories

For	Key
E346958733290	03B587332
E347158733273	03B587332

Spare Parts

For	Nut	Plug	Stop screw
E346958733290	08B587332	950A0406	19B58727
E347158733273	08B587332	950A0606	19B58735

Please check availability in current price and stock-list

EPB 5023 – Greenstock blanks

DIN 69871-ADB

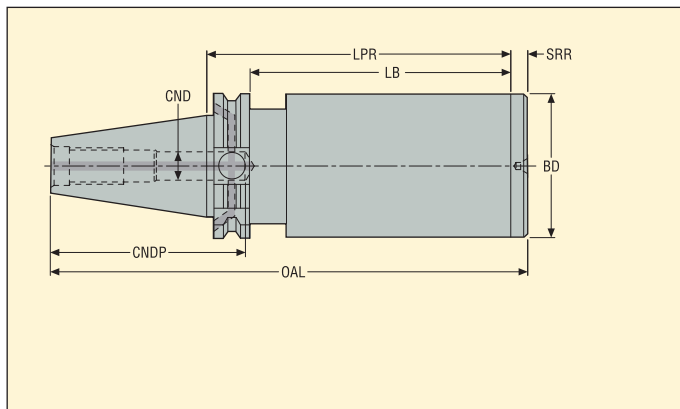

Machine side	Designation	Dimensions in mm							RFID hole	Balancing	
		LPR	LB	SRR	BD	CND	OAL	CNDP			
DIN40 ADB	E3469502363250	250,0	231,0	8,0	63,0	10,0	326,4	85,0	1	PB	6,48
DIN50 ADB	E3471502363315	315,0	296,0	8,0	63,0	21,0	424,7	61,5	1	PB	10,04
	E3471502395315	315,0	296,0	8,0	95,0	21,0	424,7	61,5	1	PB	19,00

Spare Parts

For Taper	Plug
DIN40	950A0406
DIN50	950A0606

Please check availability in current price and stock-list

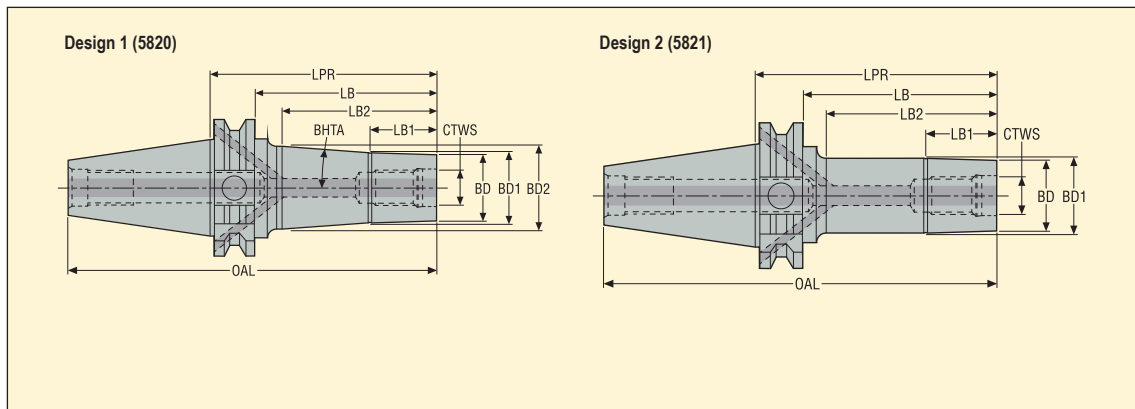

Machine side	Workpiece side	Designation	Dimensions in mm									BHTA°	Design	RFID hole	Balancing	KG
			LPR	LB	LB2	LB1	BD	BD2	BD1	OAL						
DIN40 ADB/ CAT40	M6	E347658200660	60,0	41,0	25,0	10,0	11,0	14,5	11,7	128,4	5,3	1	1	G6.3	1,00	
	M8	E347658200860	60,0	41,0	25,0	10,0	13,5	18,5	15,7	128,4	5,3	1	1	G6.3	1,00	
	M10	E347658201040	40,0	21,0	5,0	5,0	18,5	19,7	19,7	108,4	6,8	1	1	G6.3	1,00	
	M10	E347658201060	60,0	41,0	25,0	10,0	18,5	23,0	19,7	128,4	6,3	1	1	G6.3	1,00	
	M10	E347658201085	85,0	66,0	50,0	15,0	18,5	24,5	19,7	153,4	3,9	1	1	G6.3	1,10	
	M10	E3476582010135	135,0	116,0	100,0	20,0	18,5	27,5	19,7	203,4	2,8	1	1	G6.3	1,30	
	M10	E347658211060	60,0	41,0	25,0	10,0	18,5	–	18,5	128,4	–	2	1	G6.3	1,00	
	M12	E347658201240	40,0	21,0	5,0	5,0	23,0	24,7	24,7	108,4	9,6	1	1	G6.3	1,00	
	M12	E347658201260	60,0	41,0	25,0	10,0	23,0	28,5	24,7	128,4	7,2	1	1	G6.3	1,10	
	M12	E347658201285	85,0	66,0	50,0	20,0	23,0	30,0	24,7	153,4	5,0	1	1	G6.3	1,20	
	M12	E3476582012110	110,0	91,0	75,0	25,0	23,0	31,5	24,7	178,4	3,9	1	1	G6.3	1,30	
	M12	E3476582012185	185,0	166,0	150,0	30,0	23,0	42,5	24,7	253,4	4,2	1	1	G6.3	1,80	
	M12	E347658211260	60,0	41,0	25,0	10,0	23,0	–	23,5	128,4	–	2	1	G6.3	1,10	
	M12	E347658211285	85,0	66,0	50,0	20,0	23,0	–	23,5	153,4	–	2	1	G6.3	1,10	
	M16	E347658201640	40,0	21,0	5,0	5,0	30,0	31,7	31,7	108,4	9,6	1	1	G6.3	1,00	
	M16	E347658201660	60,0	41,0	25,0	10,0	30,0	35,5	31,7	128,4	7,2	1	1	G6.3	1,10	
	M16	E347658201685	85,0	66,0	50,0	20,0	30,0	37,0	31,7	153,4	5,0	1	1	G6.3	1,30	
	M16	E3476582016110	110,0	91,0	75,0	25,0	30,0	38,5	31,7	178,4	3,9	1	1	G6.3	1,50	
	M16	E3476582016135	135,0	116,0	100,0	30,0	30,0	40,5	31,7	203,4	3,6	1	1	G6.3	1,60	
	M16	E3476582016185	185,0	166,0	150,0	35,0	30,0	43,5	31,7	253,4	2,9	1	1	G6.3	2,10	
M16	E347658211685	85,0	66,0	50,0	20,0	30,0	–	30,5	153,4	–	2	1	G6.3	1,20		
M16	E3476582116110	110,0	91,0	75,0	25,0	30,0	–	30,5	178,4	–	2	1	G6.3	1,30		
M16	E3476582116135	135,0	116,0	100,0	30,0	30,0	–	30,5	203,4	–	2	1	G6.3	1,50		

Spare Parts

For Taper	Plug
DIN40	950A0406

Please check availability in current price and stock-list

EPB 401 – Graflex® arbors

DIN

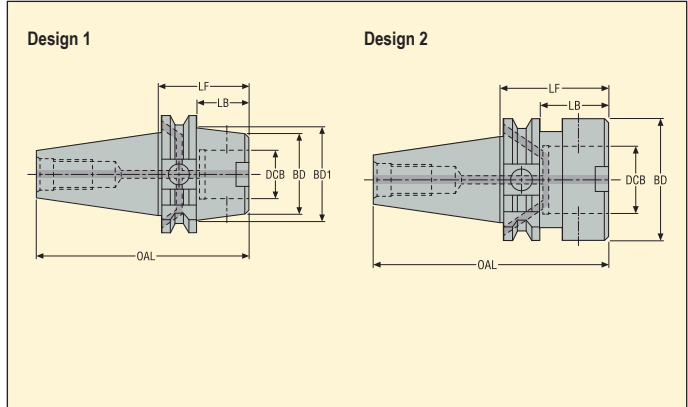

Machine side	Workpiece side Graflex		Designation	Dimensions in mm					Design	RFID hole	Balancing	
	Size	DCB mm		LF	LB	BD1	BD	OAL				
DIN40 ADB	G1	11	EM34694011190	90,0	70,9	20,0	20,0	158,4	2	1	G6.3	0,94
	G2	14	EM34694011435	35,0	15,9	25,0	25,0	103,4	2	1	G6.3	0,83
	G2	14	EM34694011490	90,0	70,9	25,0	25,0	158,4	2	1	G6.3	1,02
	G3	18	EM34694011835	35,0	15,9	50,0	32,0	103,4	1	1	G6.3	0,91
	G3	18	EM346940118100	100,0	80,9	32,0	32,0	168,4	2	1	G6.3	1,22
	G4	22	EM34694012235	35,0	15,9	50,0	40,0	103,4	1	1	G6.3	0,92
	G4	22	EM346940122100	100,0	80,9	40,0	40,0	168,4	2	1	G6.3	1,44
	G5	28	EM34694012840	40,0	20,9	50,0	50,0	108,4	2	1	PB	0,93
	G5	28	EM34694012880	80,0	60,9	50,0	50,0	148,4	2	1	PB	1,50
	G5	28	EM346940128120	120,0	100,9	50,0	50,0	188,4	2	1	PB	2,08
	G6	36	EM34694013660	60,0	40,9	63,0	63,0	128,4	2	1	PB	1,24
	G6	36	EM346940136120	120,0	100,9	63,0	63,0	188,4	2	1	PB	2,65

Accessories

For size	Locking key
G1	03H02
G2	03H025
G3	03H03
G4	03H04
G5	03H05
G6	03H06

Spare Parts

For size	Assembly screw	Plug
G1	90F1	950A0406
G2	90F2	950A0406
G3	90F3	950A0406
G4	90F4	950A0406
G5	90F5	950A0406
G6	90F6	950A0406

Please check availability in current price and stock-list

EPB 401 – Graflex® arbors

DIN

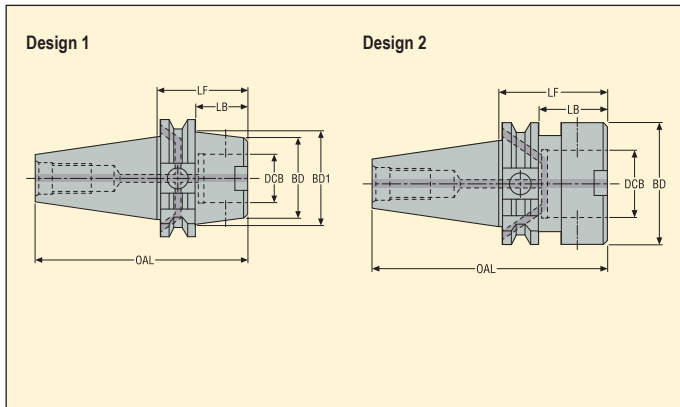

Machine side	Workpiece side Graflex		Designation	Dimensions in mm					Design	RFID hole	Balancing	KG
	Taper	Size		DCB mm	LF	LB	BD1	BD				
DIN50 ADB	G2	14	EM347140114100	100,0	80,9	25,0	25,0	201,7	2	1	G6.3	2,80
	G3	18	EM34714011835	35,0	15,9	32,0	32,0	136,7	2	1	G6.3	2,67
	G3	18	EM347140118110	110,0	90,9	32,0	32,0	211,7	2	1	G6.3	3,00
	G4	22	EM34714012235	35,0	15,9	80,0	40,0	136,7	1	1	G6.3	2,88
	G4	22	EM347140122120	120,0	100,9	40,0	40,0	221,7	2	1	G6.3	3,36
	G5	28	EM34714012840	40,0	20,9	50,0	50,0	141,7	2	1	PB	2,75
	G5	28	EM347140128100	100,0	80,9	50,0	50,0	201,7	2	1	PB	3,56
	G5	28	EM347140128140	140,0	120,9	50,0	50,0	241,7	2	1	PB	4,08
	G6	36	EM34714013645	45,0	25,9	63,0	63,0	146,7	2	1	PB	2,88
	G6	36	EM347140136100	100,0	80,9	63,0	63,0	201,7	2	1	PB	4,08
	G6	36	EM347140136140	140,0	120,9	63,0	63,0	241,7	2	1	PB	4,99
	G7	46	EM34714014650	50,0	30,9	90,0	90,0	151,7	2	1	PB	3,23
	G7	46	EM347140146120	120,0	100,9	90,0	90,0	221,7	2	1	PB	6,48
	G7	46	EM347140146200	200,0	180,9	90,0	90,0	301,7	2	1	PB	10,40

Accessories

For size	Locking key
G2	03H025
G3	03H03
G4	03H04
G5	03H05
G6	03H06
G7	03H10

Spare Parts

For size	Assembly screw	Plug
G2	90F2	950A0606
G3	90F3	950A0606
G4	90F4	950A0606
G5	90F5	950A0606
G6	90F6	950A0606
G7	90F7	950A0606

Please check availability in current price and stock-list

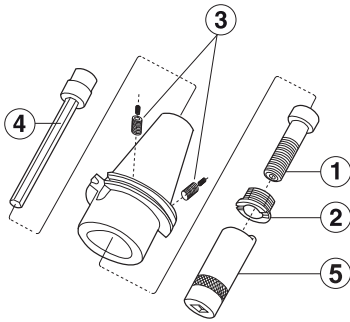



Accessories:
 3 = Spanner
 4 = Extension key

Spare parts:
 1 = Centre screw
 2 = Retaining nut
 3 = Plugs (dowels)

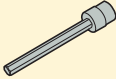
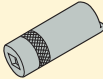
Accessories

For	Extension key	Spanner
		
C3-400	5680015-05	5680065-13
C3-500	5680015-05	5680065-13
C4-400	5680015-05	5680065-10
C4-500	5680015-05	5680065-10
C5-400	5680015-01	5680065-11
C5-500	5680015-01	5680065-11
C6-400	5680015-01	5680065-12
C6-500	5680015-02	5680065-12
C8	5680015-02	5680065-12

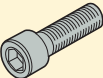
Spare Parts

For	Centre screw	Plug	Retaining nut
			
C3-400	5512063-10	564301701	5512091-04
C3-500	5512063-10	564301702	5512091-04
C4-400	5512063-07	564301701	5512091-03
C4-500	5512063-07	564301702	5512091-03
C5-400	5512063-08	564301701	5512091-01
C5-500	5512063-08	564301702	5512091-01
C6-400	5512063-13	564301701	5512091-02
C6-500	5512063-09	564301702	5512091-02
C8	5512063-09	564301702	5512091-02



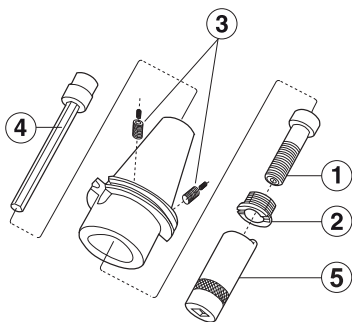



Accessories:
 4 = Extension key
 5 = Spanner

Spare parts:
 1 = Centre screw
 2 = Retaining nut
 3 = Plugs (dowels)

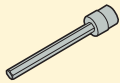
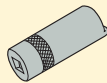
Accessories

For Taper/ size	Extension key	Spanner
		
BT TF40/ C5	5680015-01	5680065-11
BT TF40/ C6	5680015-01	5680065-12
BT TF50/ C4	5680015-05	5680065-10
BT TF50/ C5	5680015-01	5680065-11
BT TF50/ C6-C8	5680015-02	5680065-12

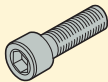
Spare Parts

For Taper/ size	Centre screw	Plug	Retaining nut
			
BT TF40/ C5	5512063-08	564301701	5512091-01
BT TF40/ C6	5512063-13	564301701	5512091-02
BT TF50/ C4	5512063-07	564301702	5512091-03
BT TF50/ C5	5512063-08	564301702	5512091-01
BT TF50/ C6-C8	5512063-09	564301702	5512091-02

EPB 5555/5556 – Steadyline®, vibration damping shell mill holders

BT JIS B 6339-ADB



- With dynamic damping, ready to use
- Direct run-out 5 µm maximum
- With coolant supply channels through the spigot

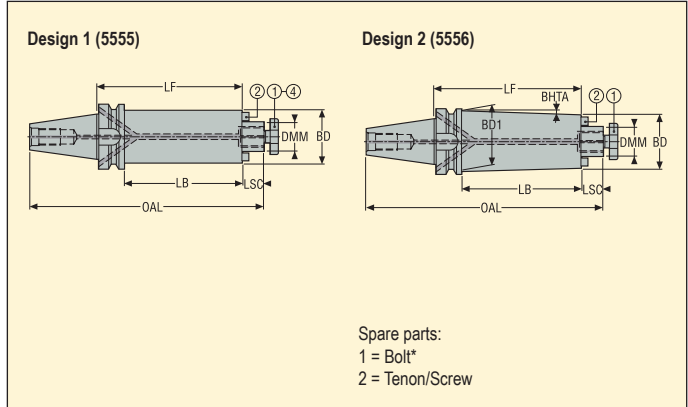

Machine side	Workpiece side	Designation	Dimensions in mm					Design	BHTA*	RFID hole	Balancing	KG	
			LF	BD	BD1	OAL	LB						LSC
BT40 ADB	16	E3414555516160	160,0	38,0	38,0	242,4	133,0	17,0	1	–	1	PB	2,23
	22	E3414555522210	210,0	48,0	48,0	294,4	183,0	19,0	1	–	1	PB	3,78
	22	E3414555622260	260,0	48,0	60,0	344,4	233,0	19,0	2	1,3	1	PB	5,40
	27	E3414555527260	260,0	60,0	60,0	346,4	233,0	21,0	1	–	1	PB	6,86
BT50 ADB	22	E3416555522210	210,0	48,0	48,0	330,8	172,0	19,0	1	–	1	PB	6,08
	22	E3416555622260	260,0	48,0	64,0	380,8	222,0	19,0	2	1,9	1	PB	7,90
	27	E3416555527260	260,0	60,0	60,0	382,8	222,0	21,0	1	–	1	PB	9,06
	27	E3416555627320	320,0	60,0	80,0	442,8	282,0	21,0	2	1,9	1	PB	12,64
	32	E3416555532330	330,0	78,0	78,0	455,8	292,0	24,0	1	–	1	PB	15,34
	40	E3416555540350	350,0	89,0	89,0	475,8	312,0	27,0	1	–	1	PB	20,70

DMM 40, includes 4 threaded holes on the bearing face according to DIN 6357

Accessories

For Taper/ DMM	Bolt, through coolant	Spanner
BT40/ 16	5801608L	5811608
BT40/ 22	5802210L	5812210
BT40/ 27	5802712L	5812712
BT50/ 22	5802210L	5812210
BT50/ 27	5802712L	5812712
BT50/ 32	5803216L	5813216
BT50/ 40	5804020L	5814020

Spare Parts*

For Taper/ DMM	Bolt	Plug	Screw	Tenon
BT40/ 16	5801608	950A0406	950D0312	16C2080810A
BT40/ 22	5802210	950A0406	950D0416	16C2101111
BT40/ 27	5802712	950A0406	950D0516	16C2121214A
BT50/ 22	5802210	950A0606	950D0416	16C2101111
BT50/ 27	5802712	950A0606	950D0516	16C2121214A
BT50/ 32	5803216	950A0606	950D0516	16C2141421A
BT50/ 40	5804020	950A0606	950D0616	16C2161621A

Please check availability in current price and stock-list

* These centre bolts are similar to the original delivered ones: check if lengths are suitable for the milling cutters used, therefore see in the Operating instructions sheet delivered with the holders or in page(s) 30

EPB 5525/5524 – Shell mill holders, with through coolant channels

BT JIS B 6339-ADB



- Direct run-out 5 µm maximum
- With coolant supply channels through the spigot

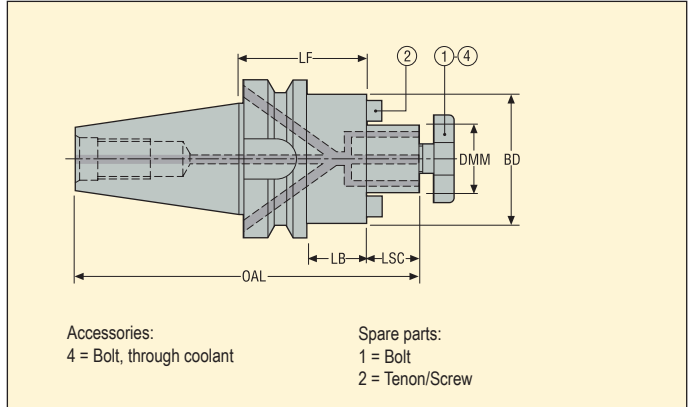

Machine side	Workpiece side	Designation	Dimensions in mm					*	RFID hole	Balancing	KG	
			LF	BD	OAL	LB	LSC					
BT50 ADB	16	E3416552516100	100,0	38,0	218,8	62,0	17,0		1	PB	4,00	
	22	E3416552522100	100,0	48,0	220,8	62,0	19,0		1	PB	4,28	
	22	E3416552522160	160,0	48,0	280,8	122,0	19,0		1	PB	5,34	
	22	E341655252255	55,0	48,0	175,8	17,0	19,0		1	PB	3,78	
	27	E341655252755	55,0	60,0	177,8	17,0	21,0	*	1	PB	3,93	
	27	E3416552527100	100,0	60,0	222,8	62,0	21,0		1	PB	4,80	
	27	E3416552527160	160,0	60,0	282,8	122,0	21,0		1	PB	6,30	
	32	E3416552532100	100,0	78,0	225,8	62,0	24,0		1	PB	5,88	
	32	E3416552532160	160,0	78,0	285,8	122,0	24,0		1	PB	8,02	
	32	E341655253255	55,0	78,0	180,8	17,0	24,0		1	PB	4,26	
	40	E3416552540100	100,0	89,0	228,8	62,0	27,0		1	PB	6,58	
	40	E3416552540160	160,0	89,0	288,8	122,0	27,0		1	PB	9,42	
	40	E341655254055	55,0	89,0	183,8	17,0	27,0		1	PB	4,50	
		27	E341655242755	55,0	48,0	177,8	28,0	21,0	*	1	PB	3,78

DMM 40, includes 4 threaded holes on the bearing face according to DIN 6357

* Diameter BD on type 5524 is smaller than on type 5525

Accessories

For DMM	Bolt, through coolant	Spanner
16	5801608L	5811608
22	5802210L	5812210
27/ 5524	5802712L	5812712
27/ 5525	5802712L	5812712
32	5803216L	5813216
40	5804020L	5814020

Spare Parts

For DMM	Bolt	Plug	Screw	Tenon
16	5801608	950A0606	950D0312	16C10810164
22	5802210	950A0606	950D0416	16C11012206
27/ 5524	5802712	950A0606	951D0512	16C127
27/ 5525	5802712	950A0606	951D0512	16C11214243
32	5803216	950A0606	951D0516	16C2141421
40	5804020	950A0606	951D0616	16C2161621

Please check availability in current price and stock-list

EPB 552 – Shell mill holders, small face – ISO 3937

BT JIS B 6339-AD



- Direct run-out 5 µm maximum
- Small workpiece side diameter BD according to ISO 3937, suitable for Seco disc mill cutters Type B

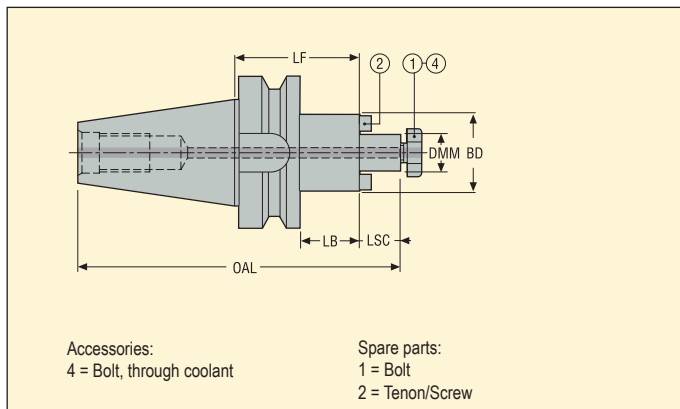

Machine side	Workpiece side	Designation	Dimensions in mm					RFID hole	Balancing	KG
			LF	BD	OAL	LB	LSC			
BT30 AD	16	E40405521640	40,0	32,0	105,4	18,0	17,0	0	PB	0,52
	22	E40405522240	40,0	40,0	107,4	18,0	19,0	0	PB	0,62
	27	E40405522740	40,0	48,0	109,4	18,0	21,0	0	PB	0,74
BT40 AD	16	E40415521652	52,0	32,0	134,4	25,0	17,0	1	PB	1,12
	22	E40415522252	52,0	40,0	136,4	25,0	19,0	1	PB	1,25
	27	E40415522752	52,0	48,0	138,4	25,0	21,0	1	PB	1,40
	32	E40415523252	52,0	58,0	141,4	25,0	24,0	1	PB	1,60
	40	E40415524060	60,0	70,0	152,4	33,0	27,0	1	PB	2,28
BT50 AD	22	E57665522263	63,0	40,0	183,8	25,0	19,0	1	PB	3,80
	27	E57665522763	63,0	48,0	185,8	25,0	21,0	1	PB	3,96
	32	E57665523263	63,0	58,0	188,8	25,0	24,0	1	PB	4,20
	40	E57665524063	63,0	70,0	191,8	25,0	27,0	1	PB	4,56

Accessories

For DMM	Bolt, through coolant	Spanner
16	5801608L	5811608
22	5802210L	5812210
27	5802712L	5812712
32	5803216L	5813216
40	5804020L	5814020

Spare Parts

For DMM	Bolt	Screw	Tenon
16	5801608	950D0308	16C116
22	5802210	951D0410	16C122
27	5802712	951D0512	16C127
32	5803216	951D0514	16C132
40	5804020	951D0616	16C140

Please check availability in current price and stock-list



- Direct run-out 3 µm maximum
- Weldon ØDCBN-DCBX 16, 20, 25, 32 and 40 with ground face (Seco-Weldon compatible)

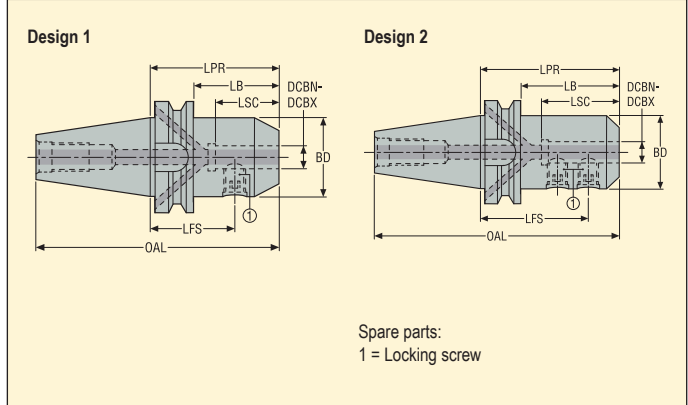

Machine side	Workpiece side	Designation	Dimensions in mm						Design	RFID hole	Balancing	KG
			LPR	LB	LSC	BD	OAL	LFS				
BT40 ADB	6	E34145840650	50,0	23,0	27,0	25,0	115,4	32,5	1	1	PB	1,00
	6	E341458406120	120,0	93,0	27,0	25,0	185,4	102,5	1	1	PB	1,30
	8	E34145840850	50,0	23,0	30,0	28,0	115,4	32,5	1	1	PB	1,05
	10	E34145841063	63,0	36,0	36,0	35,0	128,4	43,5	1	1	PB	1,20
	12	E34145841263	63,0	36,0	43,0	42,0	128,4	41,0	1	1	PB	1,30
	12	E341458412120	120,0	93,0	43,0	42,0	185,4	98,0	1	1	PB	1,85
	14	E34145841463	63,0	36,0	43,0	44,0	128,4	41,0	1	1	PB	1,30
	16	E34145841663	63,0	36,0	46,0	48,0	128,4	39,5	1	1	PB	1,35
	16	E341458416120	120,0	93,0	46,0	48,0	185,4	96,5	1	1	PB	2,15
	18	E34145841863	63,0	36,0	46,0	50,0	128,4	39,5	1	1	PB	1,40
	20	E34145842063	63,0	36,0	48,0	52,0	128,4	38,5	1	1	PB	1,35
	20	E341458420120	120,0	93,0	48,0	52,0	185,4	95,5	1	1	PB	2,30
	25	E34145842590	90,0	55,0	54,0	63,0	155,4	66,5	2	1	PB	2,20
	32	E341458432100	100,0	73,0	58,0	72,0	165,4	76,5	2	1	PB	2,70

Spare Parts

For DCBN-DCBX	Locking screw	Plug
6	951C0610	950A0406
8	951C0810	950A0406
10	951C1012	950A0406
12-14	951C1216	950A0406
16-18	951C1416	950A0406
20	951C1616	950A0406
25	951C1820	950A0406
32	951C2020	950A0406

Please check availability in current price and stock-list

EPB 584 – Side lock holders, Weldon – DIN 1835 Form B/ DIN 6535 Form HB

BT JIS B 6339-ADB



- Direct run-out 3 μm maximum
- Weldon ØDCBN-DCBX 16, 20, 25, 32 and 40 with ground face (Seco-Weldon compatible)

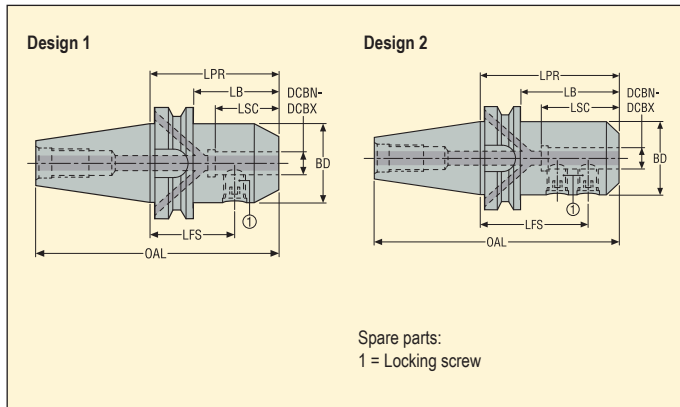

Machine side	Workpiece side	Designation	Dimensions in mm						Design	RFID hole	Balancing	KG
			LPR	LB	LSC	BD	OAL	LFS				
BT50 ADB	DCBN-DCBX mm											
	12	E34165841280	80,0	42,0	43,0	42,0	181,8	58,0	1	1	PB	4,00
	14	E34165841480	80,0	42,0	43,0	44,0	181,8	58,0	1	1	PB	4,00
	16	E34165841680	80,0	42,0	46,0	48,0	181,8	56,5	1	1	PB	4,10
	16	E341658416120	120,0	82,0	46,0	48,0	221,8	96,5	1	1	PB	4,60
	18	E34165841880	80,0	42,0	46,0	50,0	181,8	56,5	1	1	PB	3,94
	20	E34165842080	80,0	42,0	48,0	52,0	181,8	55,5	1	1	PB	3,98
	20	E341658420120	120,0	82,0	48,0	52,0	221,8	95,5	1	1	PB	4,75
	25	E341658425100	100,0	62,0	54,0	65,0	201,8	76,5	2	1	PB	4,90
	25	E341658425120	120,0	82,0	54,0	65,0	221,8	96,5	2	1	PB	5,12
	32	E341658432105	105,0	67,0	58,0	72,0	206,8	81,5	2	1	PB	5,25
	40	E341658440120	120,0	82,0	68,0	80,0	221,8	90,5	2	1	PB	6,00
	50	E341658450130	130,0	80,0	78,0	100,0	231,8	95,5	2	1	PB	7,65

Spare Parts

For DCBN-DCBX	Locking screw	Plug
12-14	951C1216	950A0606
16-18	951C1416	950A0606
20	951C1616	950A0606
25	951C1820	950A0606
32-40	951C2020	950A0606
50	951C2425	950A0606

Please check availability in current price and stock-list

EPB 5603 – Shrinkfit holders, DIN type

BT JIS B 6339-ADB



- Run-out maximum: 3 µm at 3 x ØDCBN-DCBX and 3 µm direct
- Delivered with one stop screw

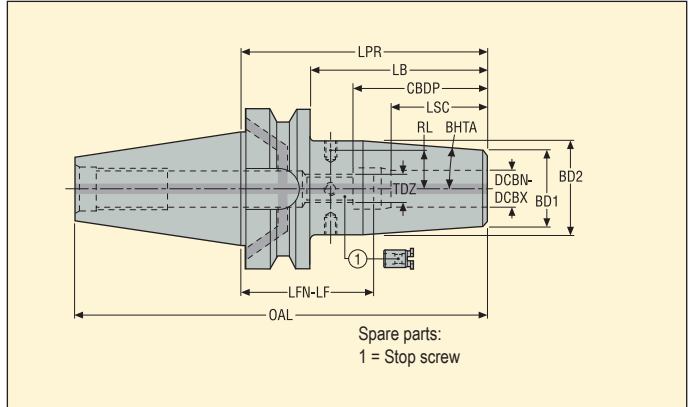

Machine side	Workpiece side	Designation	Dimensions in mm								TDZ	BHTA°	RL mm	RFID hole	Balancing	KG
			LPR	LB	CBDP	LSC	BD2	BD1	OAL	LFN-LF						
BT40 ADB	6	E341456030690	90,0	63,0	37,5	22,0	27,0	21,0	155,4	54,0-68,0	M5x0.8	4,5	10,5	1	G2.5	1,18
	6	E3414560306120	120,0	93,0	37,5	22,0	27,0	21,0	185,4	84,0-94,0	M5x0.8	4,5	10,5	1	G2.5	1,31
	6	E3414560306160	160,0	133,0	37,5	22,0	27,0	21,0	225,4	124,0-138,0	M5x0.8	4,5	10,5	1	G2.5	1,45
	8	E341456030890	90,0	63,0	37,5	26,0	27,0	21,0	155,4	54,0-64,0	M6x1	4,5	10,5	1	G2.5	1,18
	8	E3414560308120	120,0	93,0	37,5	26,0	27,0	21,0	185,4	84,0-94,0	M6x1	4,5	10,5	1	G2.5	1,30
	8	E3414560308160	160,0	133,0	37,5	26,0	27,0	21,0	225,4	124,0-134,0	M6x1	4,5	10,5	1	G2.5	1,44
	10	E341456031090	90,0	63,0	42,5	31,0	32,0	24,0	155,4	49,0-59,0	M8x1	4,5	13,0	1	G2.5	1,23
	10	E3414560310120	120,0	93,0	42,5	31,0	32,0	24,0	185,4	79,0-89,0	M8x1	4,5	13,0	1	G2.5	1,50
	10	E3414560310160	160,0	133,0	42,5	31,0	32,0	24,0	225,4	119,0-129,0	M8x1	4,5	13,0	1	G2.5	1,70

For Shrinkfit extensions, see page(s) 221

Accessories

For DCBN-DCBX	Balancing screws
6	90ZQ01
8	90ZQ01
10	90ZQ01

Spare Parts

For DCBN-DCBX	Plug	Stop screw
6	950A0406	19BDR05165
8	950A0406	19BDR06165
10	950A0406	19BDR08165

Please check availability in current price and stock-list

EPB 5603 – Shrinkfit holders, DIN type

BT JIS B 6339-ADB



- Run-out maximum: 3 μm at 3 x ØDCBN-DCBX and 3 μm direct
- Delivered with one stop screw

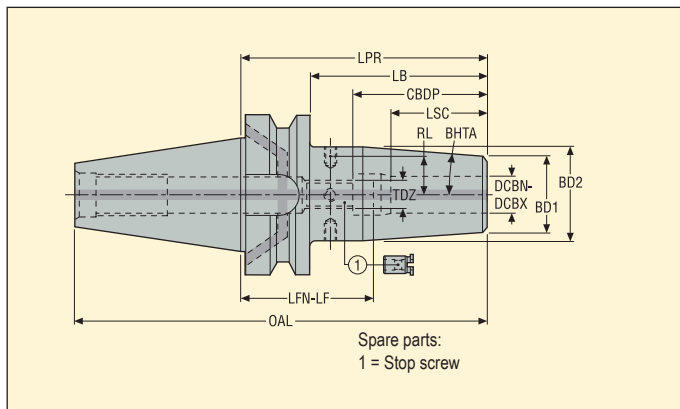

Machine side	Workpiece side	Designation	Dimensions in mm								TDZ	BHTA°	RL mm	RFID hole	Balancing	KG
			LPR	LB	CBDP	LSC	BD2	BD1	OAL	LFN-LF						
BT40 ADB	12	E341456031290	90,0	63,0	47,5	34,0	32,0	24,0	155,4	44,0-56,0	M10x1	4,5	13,0	1	G2.5	1,21
	12	E3414560312120	120,0	93,0	47,5	34,0	32,0	24,0	185,4	74,0-86,0	M10x1	4,5	13,0	1	G2.5	1,39
	12	E3414560312160	160,0	133,0	47,5	34,0	32,0	24,0	225,4	114,0-126,0	M10x1	4,5	13,0	1	G2.5	1,70
	14	E341456031490	90,0	63,0	47,5	34,0	34,0	27,0	155,4	44,0-56,0	M10x1	4,5	14,0	1	G2.5	1,35
	14	E3414560314120	120,0	93,0	47,5	34,0	34,0	27,0	185,4	74,0-86,0	M10x1	4,5	14,0	1	G2.5	1,50
	16	E341456031690	90,0	63,0	50,5	39,0	34,0	27,0	155,4	41,0-51,0	M12x1	4,5	14,0	1	G2.5	1,24
	16	E3414560316120	120,0	93,0	50,5	39,0	34,0	27,0	185,4	71,0-81,0	M12x1	4,5	14,0	1	G2.5	1,50
	16	E3414560316160	160,0	133,0	50,5	39,0	34,0	27,0	225,4	111,0-121,0	M12x1	4,5	14,0	1	G2.5	1,70
	18	E341456031890	90,0	63,0	50,5	39,0	42,0	33,0	155,4	41,0-51,0	M12x1	4,5	18,0	1	G2.5	1,40
	20	E341456032090	90,0	63,0	52,5	41,0	42,0	33,0	155,4	39,0-49,0	M16x1	4,5	18,0	1	G2.5	1,34
	20	E3414560320120	120,0	93,0	52,5	41,0	42,0	33,0	185,4	69,0-79,0	M16x1	4,5	18,0	1	G2.5	1,70
	25	E3414560325100	100,0	73,0	58,5	47,0	53,0	44,0	165,4	43,0-53,0	M16x1	4,5	23,5	1	G2.5	1,78

For Shrinkfit extensions, see page(s) 221

Accessories

For DCBN-DCBX	Balancing screws
12-14	90ZQ01
16-18	90ZQ01
20-25	90ZQ01

Spare Parts

For DCBN-DCBX	Plug	Stop screw
12-14	950A0406	19BDR10165
16-18	950A0406	19BDR12165
20-25	950A0406	19BDR16165

Please check availability in current price and stock-list

EPB 5603 – Shrinkfit holders, DIN type

BT JIS B 6339-ADB



- Run-out maximum: 3 μm at 3 x ØDCBN-DCBX and 3 μm direct
- Delivered with one stop screw

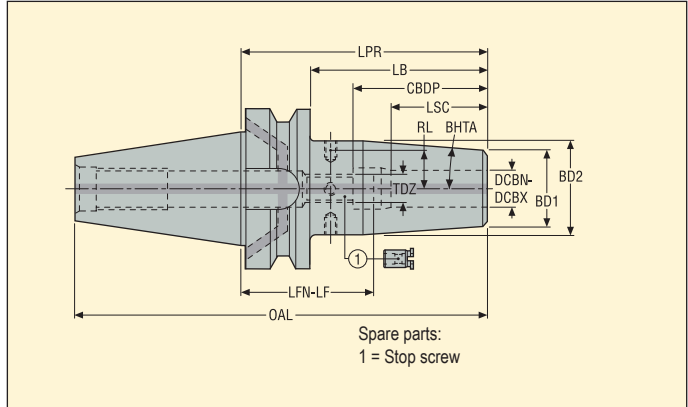

Machine side	Workpiece side	Designation	Dimensions in mm								TDZ	BHTA°	RL mm	RFID hole	Balancing	KG
			LPR	LB	CBDP	LSC	BD2	BD1	OAL	LFN-LF						
BT50 ADB	6	E3416560306100	100,0	62,0	37,5	22,0	27,0	21,0	201,8	64,0-78,0	M5x0,8	4,5	10,5	1	G2.5	3,76
	6	E3416560306160	160,0	122,0	37,5	22,0	27,0	21,0	261,8	124,0-138,0	M5x0,8	4,5	10,5	1	G2.5	3,98
	8	E3416560308100	100,0	62,0	37,5	26,0	27,0	21,0	201,8	64,0-74,0	M6x1	4,5	10,5	1	G2.5	3,80
	8	E3416560308160	160,0	122,0	37,5	26,0	27,0	21,0	261,8	124,0-134,0	M6x1	4,5	10,5	1	G2.5	4,00
	10	E3416560310100	100,0	62,0	42,5	31,0	32,0	24,0	201,8	59,0-69,0	M8x1	4,5	13,0	1	G2.5	3,81
	10	E3416560310160	160,0	122,0	42,5	31,0	32,0	24,0	261,8	119,0-129,0	M8x1	4,5	13,0	1	G2.5	4,15
	12	E3416560312100	100,0	62,0	47,5	34,0	32,0	24,0	201,8	54,0-66,0	M10x1	4,5	13,0	1	G2.5	3,80
	12	E3416560312160	160,0	122,0	47,5	34,0	32,0	24,0	261,8	114,0-126,0	M10x1	4,5	13,0	1	G2.5	4,14
	14	E3416560314100	100,0	62,0	47,5	34,0	34,0	27,0	201,8	54,0-66,0	M10x1	4,5	14,0	1	G2.5	3,85
	16	E3416560316100	100,0	62,0	50,5	39,0	34,0	27,0	201,8	51,0-61,0	M12x1	4,5	14,0	1	G2.5	3,82
	16	E3416560316160	160,0	122,0	50,5	39,0	34,0	27,0	261,8	111,0-121,0	M12x1	4,5	14,0	1	G2.5	4,20
	18	E3416560318100	100,0	62,0	50,5	39,0	42,0	33,0	201,8	51,0-61,0	M12x1	4,5	18,0	1	G2.5	3,95
	20	E3416560320100	100,0	62,0	52,5	41,0	42,0	33,0	201,8	49,0-59,0	M16x1	4,5	18,0	1	G2.5	3,90
	20	E3416560320160	160,0	122,0	52,5	41,0	42,0	33,0	261,8	109,0-119,0	M16x1	4,5	18,0	1	G2.5	4,49
	25	E3416560325110	110,0	72,0	58,5	47,0	53,0	44,0	211,8	53,0-63,0	M16x1	4,5	23,5	1	G2.5	4,35
	25	E3416560325160	160,0	122,0	58,5	47,0	53,0	44,0	261,8	103,0-113,0	M16x1	4,5	23,5	1	G2.5	5,20
32	E3416560332110	110,0	72,0	62,5	51,0	53,0	44,0	211,8	49,0-59,0	M16x1	4,5	23,5	1	G2.5	4,20	

For Shrinkfit extensions, see page(s) 221

Accessories

For DCBN-DCBX	Balancing screws
6	90ZQ01
8	90ZQ01
10	90ZQ01
12-14	90ZQ01
16-18	90ZQ01
20-32	90ZQ01

Spare Parts

For DCBN-DCBX	Plug	Stop screw
6	950A0606	19BDR05165
8	950A0606	19BDR06165
10	950A0606	19BDR08165
12-14	950A0606	19BDR10165
16-18	950A0606	19BDR12165
20-32	950A0606	19BDR16165

Please check availability in current price and stock-list

EPB 5600 – Shrinkfit holders, reinforced

BT JIS B 6339-ADB



- Reinforced design with wider front and tapered body
- Run-out maximum: 3 μm at 3 x ØDCBN-DCBX and 3 μm direct
- With coolant supply channels towards the tool (plugged)
- Delivered with one stop screw

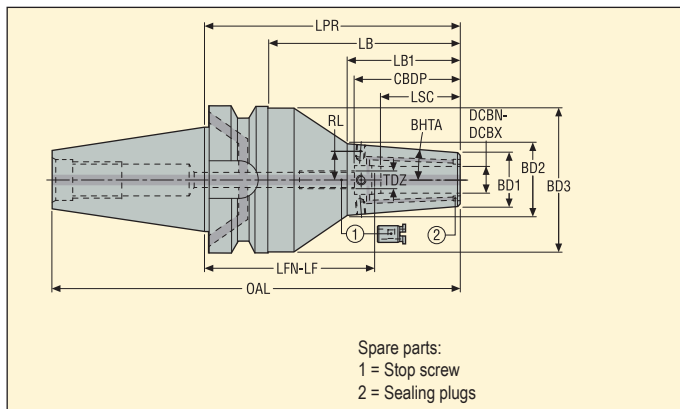

Machine side	Workpiece side	DCBN-DCBX mm	Designation	Dimensions in mm										TDZ	BHTA°	RL mm	RFID hole	Balancing	KG
				LPR*	LB	LB1	CBDP	LSC	BD3	BD2	BD1	OAL	LFN-LF						
BT40 ADB	6	E3414560006130	130,0	103,0	52,0	37,5	22,0	61,5	32,2	24,0	195,4	94,0-108,0	M5	4,5	12,0	1	G2,5	2,00	
	8	E3414560008130	130,0	103,0	52,0	37,5	26,0	61,5	32,2	24,0	195,4	94,0-104,0	M6	4,5	12,0	1	G2,5	2,00	
	10	E3414560010130	70,0	43,0	43,0	42,5	31,0	—	35,2	27,0	135,4	29,0-39,0	M8x1	4,5	13,5	1	G2,5	1,20	
	10	E3414560010130	130,0	103,0	52,0	42,5	31,0	61,5	35,2	27,0	195,4	89,0-99,0	M8x1	4,5	13,5	1	G2,5	2,05	
	12	E3414560012130	70,0	43,0	43,0	47,5	34,0	—	35,2	27,0	135,4	24,0-36,0	M10x1	4,5	13,5	1	G2,5	1,20	
	12	E3414560012130	130,0	103,0	103,0	47,5	34,0	61,5	35,2	27,0	195,4	84,0-96,0	M10x1	4,5	13,5	1	G2,5	2,05	
	16	E3414560016130	75,0	48,0	48,0	50,5	39,0	—	42,1	33,0	140,4	26,0-36,0	M12x1	4,5	17,0	1	G2,5	1,30	
	16	E3414560016130	130,0	103,0	58,0	50,5	39,0	61,5	42,1	33,0	195,4	81,0-91,0	M12x1	4,5	17,0	1	G2,5	2,15	
	20	E3414560020130	75,0	48,0	48,0	52,5	41,0	—	53,1	44,0	140,4	24,0-34,0	M16x1	4,5	21,5	1	G2,5	1,47	

* LPR = 70, 75, 85: Extra-short holders requiring a dedicated Easyshrink® cooling contact bush type "5600 extra short", see page(s) 339

Accessories

For DCBN-DCBX	Balancing screws
6	90ZQ01
8	90ZQ01
10	90ZQ01
12	90ZQ01
16	90ZQ01
20	90ZQ01

Spare Parts

For DCBN-DCBX	Plug	Sealing plugs	Stop screw
6	950A0406	90AI03	19BDR05165
8	950A0406	90AI03	19BDR06165
10	950A0406	90AI03	19BDR08165
12	950A0406	90AI03	19BDR10165
16	950A0406	90AI03	19BDR12165
20	950A0406	90AI04	19BDR16165

Please check availability in current price and stock-list

EPB 5600 – Shrinkfit holders, reinforced

BT JIS B 6339-ADB



- Reinforced design with wider front and tapered body
- Run-out maximum: 3 µm at 3 x ∅DCBN-DCBX and 3 µm direct
- With coolant supply channels towards the tool (plugged)
- Delivered with one stop screw

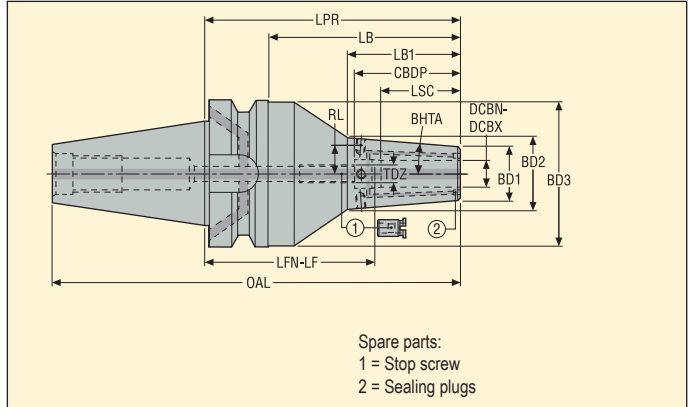

Machine side	Workpiece side	Designation	Dimensions in mm										TDZ	BHTA°	RL mm	RFID hole	Balancing	KG
			LPR*	LB	LB1	CBDP	LSC	BD3	BD2	BD1	OAL	LFN-LF						
BT50 ADB	6	E3416560006160	160,0	122,0	52,0	37,5	22,0	97,5	32,2	24,0	261,8	124,0-138,0	M5	4,5	12,0	1	G2.5	6,15
	8	E3416560008160	160,0	122,0	122,0	37,5	26,0	97,5	32,2	24,0	261,8	124,0-134,0	M6	4,5	12,0	1	G2.5	6,10
	10	E3416560010100	100,0	62,0	62,0	42,5	31,0	-	35,2	27,0	201,8	59,0-69,0	M8x1	4,5	13,5	1	G2.5	4,00
	10	E3416560010160	160,0	122,0	52,0	42,5	31,0	97,5	35,2	27,0	261,8	119,0-129,0	M8x1	4,5	13,5	1	G2.5	6,20
	12	E3416560012100	100,0	62,0	62,0	47,5	34,0	-	35,2	27,0	201,8	54,0-66,0	M10x1	4,5	13,5	1	G2.5	3,95
	12	E3416560012160	160,0	122,0	52,0	47,5	34,0	97,5	35,2	27,0	261,8	114,0-126,0	M10x1	4,5	13,5	1	G2.5	6,20
	16	E3416560016100	100,0	62,0	62,0	50,5	39,0	-	42,1	33,0	201,8	51,0-61,0	M12x1	4,5	17,0	1	G2.5	4,05
	16	E3416560016160	160,0	122,0	58,0	50,5	39,0	97,5	42,1	33,0	261,8	111,0-121,0	M12x1	4,5	17,0	1	G2.5	6,30
	20	E3416560020100	100,0	62,0	62,0	52,5	41,0	-	53,1	44,0	201,8	49,0-59,0	M16x1	4,5	21,5	1	G2.5	4,33
	20	E3416560020160	160,0	122,0	58,0	52,5	41,0	97,5	53,1	44,0	261,8	109,0-119,0	M16x1	4,5	21,5	1	G2.5	6,76
	25	E3416560025100	100,0	62,0	62,0	58,5	47,0	-	57,1	48,0	201,8	43,0-53,0	M16x1	4,5	25,0	1	G2.5	4,46
	25	E3416560025160	160,0	122,0	122,0	58,5	47,0	97,5	57,1	48,0	261,8	103,0-113,0	M16x1	4,5	25,0	1	G2.5	7,00
	32	E3416560032105	105,0	67,0	67,0	62,5	51,0	-	57,1	48,0	206,8	44,0-54,0	M16x1	4,5	25,0	1	G2.5	4,40

* E3416560025100, E3416560032105: Extra-short holders requiring a dedicated Easyshrink® cooling contact bush type "5600 extra short", see page(s) 339

Accessories

For DCBN-DCBX	Balancing screws
6	90ZQ01
8	90ZQ01
10	90ZQ01
12	90ZQ01
16	90ZQ01
20-32	90ZQ01

Spare Parts

For DCBN-DCBX	Plug	Sealing plugs	Stop screw
6	950A0606	90AI03	19BDR05165
8	950A0606	90AI03	19BDR06165
10	950A0606	90AI03	19BDR08165
12	950A0606	90AI03	19BDR10165
16	950A0606	90AI03	19BDR12165
20-32	950A0606	90AI04	19BDR16165

Please check availability in current price and stock-list

EPB 5600P Safe-Lock™ – Shrinkfit holders, reinforced and with tool pull-out protection

BT JIS B 6339-ADB



- With Safe-Lock™ tool pull-out protection system
- Reinforced design of EPB 5600
- Run-out maximum: 3 μm at 3 x ØDCBN-DCBX and 3 μm direct
- With coolant supply channels towards the tool (plugged)
- Delivered with one stop screw fitted

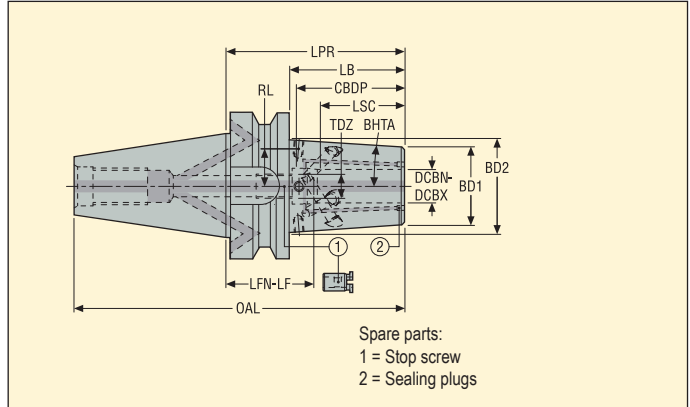

Machine side	Workpiece side	Designation	Dimensions in mm								TDZ	BHTA°	RL mm	RFID hole	Balancing	KG
			LPR*	LB	CBDP	LSC	BD2	BD1	OAL	LFN-LF						
BT40 ADB	12	E341456001270P	70,0	43,0	47,5	34,0	33,8	27,0	135,4	24,0-32,5	M10x1	4,5	13,5	1	G2.5	1,20
	16	E341456001675P	75,0	48,0	50,5	39,0	40,6	33,0	140,4	26,0-34,0	M12x1	4,5	17,0	1	G2.5	1,30
	20	E341456002075P	75,0	48,0	52,5	41,0	51,6	44,0	140,4	24,0-32,0	M16x1	4,5	21,5	1	G2.5	1,50
	25	E341456002585P	85,0	58,0	58,5	47,0	59,13	50,0	150,4	28,0-36,0	M16x1	4,5	25,0	1	G2.5	1,80
BT50 ADB	12	E3416560012100P	100,0	62,0	47,5	34,0	36,8	27,0	201,8	54,0-62,5	M10x1	4,5	13,5	1	G2.5	4,00
	16	E3416560016100P	100,0	62,0	50,5	39,0	42,8	33,0	201,8	51,0-59,0	M12x1	4,5	17,0	1	G2.5	4,10
	20	E3416560020100P	100,0	62,0	52,5	41,0	53,8	44,0	201,8	49,0-57,0	M16x1	4,5	21,5	1	G2.5	4,40
	25	E3416560025100P	100,0	62,0	58,5	47,0	59,8	48,0	201,8	53,0-41,0	M16x1	4,5	25,0	1	G2.5	4,50
	32	E3416560032105P	105,0	67,0	62,5	51,0	60,6	48,0	206,8	44,0-54,0	M16x1	4,5	25,0	1	G2.5	4,40

* E341456001270P, E341456001675P, E341456002075P, E341456002585P, E3416560025100P, E3416560032105P: Extra-short holders requiring a dedicated Easyshrink® cooling contact bush type "5600 extra short", see page(s) 339

Accessories

For Taper/ DCBN-DCBX	Balancing screws
BT40/ 12-16	90ZQ01
BT40/ 20-25	90ZQ01
BT50/ 12-16	90ZQ01
BT50/ 20-32	90ZQ01

Spare Parts

For Taper/ DCBN-DCBX	Plug	Sealing plugs	Stop screw
BT40/ 12-16	950A0406	90AI03	-
BT40/ 20-25	950A0406	90AI04	19BDR16165
BT50/ 12-16	950A0606	90AI03	-
BT50/ 20-32	950A0606	90AI04	19BDR16165

Please check availability in current price and stock-list

(-) For DCBN-DCBX 12 and 16 mm, stop screw not removable/replaceable by the user, please request a repair process

EPB 5672 – High precision collet chucks

BT JIS B 6339-AD/ADB

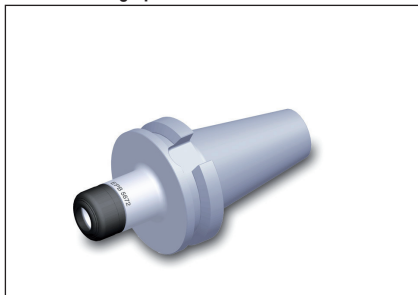

- Run-out 3 μm maximum at 3 x ∅DCBN-DCBX
- High transmittable torque
- High RPM suitable

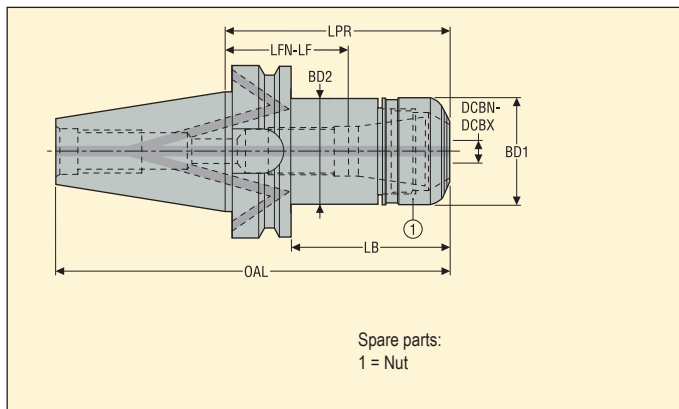

Machine side	Workpiece side	Capacity DCBN-DCBX mm	Designation	Chuck & Collet Size	Dimensions in mm					RFID hole	Balancing	KG
					LPR	BD1	BD2	OAL	LB			
BT30 AD	0,5-7,0	E404056721150	HP 11	50,0	16,0	16,0	98,4	28,0	14,0-32,0	0	G2.5	0,5
BT40 ADB	0,5-10,0	E341456721670	HP 16	70,0	30,0	30,0	135,4	43,0	39,0-40,0	1	G2.5	1,12
	0,5-10,0	E3414567216160	HP 16	160,0	30,0	30,0	225,4	133,0	129,0-130,0	1	G2.5	1,55
	1,0-16,0	E341456722570	HP 25	70,0	40,0	40,0	135,4	43,0	14,0-32,0	1	G2.5	1,19
	1,0-16,0	E3414567225160	HP 25	160,0	40,0	40,0	225,4	133,0	104,0-122,0	1	G2.5	1,96
	2,0-20,0	E341456723270	HP 32	70,0	50,0	50,0	135,4	43,0	14,0-18,0	1	G2.5	1,29
BT50 ADB	1,0-16,0	E3416567225100	HP 25	100,0	40,0	40,0	201,8	62,0	44,0-62,0	1	G2.5	3,93
	2,0-20,0	E3416567232100	HP 32	100,0	50,0	50,0	201,8	62,0	44,0-48,0	1	G2.5	4,12

For ER HP collets type 5672, see page(s) 309-313

* LFN-LF setting length onto stop screw when possible, or total available setting length for chucks without thread for stop screw

Accessories**

For Taper/size	Socket	Spanner	Stop screw	Torque key
BT30/ HP 11	03ER016	03BR016	19B5870812P1	03DYD010100
BT40/ HP 16	03ER030	03BR030	19B58711	03DYD010100
BT40/ HP 25	03ER040	03BR040	19B58718	03DYD020200
BT40/ HP 32	03ER050	03BR050	19B58722	03DYD020200
BT50/ HP 25	03ER040	03BR040	19B58718	03DYD020200
BT50/ HP 32	03ER050	03BR050	19B58722	03DYD020200

Spare Parts

For Taper/size	Nut	Plug
BT30/ HP 11	08B567211	-
BT40/ HP 16	08B567216	950A0406
BT40/ HP 25	08B567225	950A0406
BT40/ HP 32	08B567232	950A0406
BT50/ HP 25	08B567225	950A0606
BT50/ HP 32	08B567232	950A0606

Please check availability in current price and stock-list

** When using a stop screw, its tapered contact onto the tool shank can increase the tool run-out defect, For tightening torques, see page(s) 41

EPB 5834 – Hydraulic chucks

BT JIS B 6339-ADB



• Run-out 3 µm maximum at 3 x ∅DCBN-DCBX

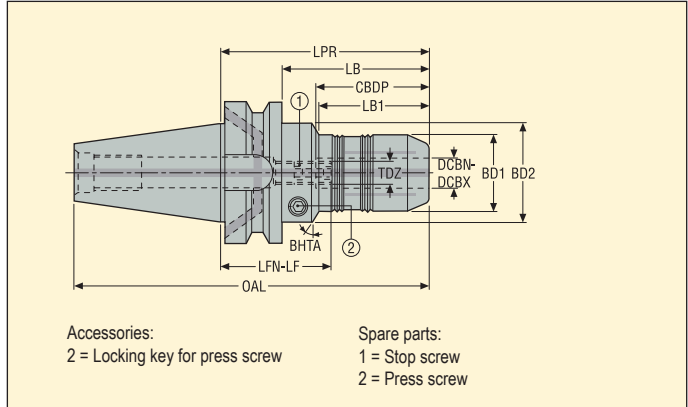

Machine side	Workpiece side	Designation	Dimensions in mm									TDZ	BHTA°	RFID hole	Balancing	KG
			LPR	LB	CBDB	LB1	BD2	BD1	OAL	LFN-LF						
BT40 ADB	6	E341458340690	90,0	63,0	38,0	23,0	50,0	26,0	155,4	52,0-62,0	M5	30,0	1	G6.3	1,55	
	8	E341458340890	90,0	63,0	38,0	24,0	50,0	28,0	155,4	52,0-62,0	M5	30,0	1	G6.3	1,55	
	10	E341458341090	90,0	63,0	42,0	34,0	50,0	30,0	155,4	48,0-58,0	M8	30,0	1	G6.3	1,47	
	12	E341458341290	90,0	63,0	47,0	40,0	50,0	32,0	155,4	43,0-53,0	M10	30,0	1	G6.3	1,42	
	14	E341458341490	90,0	63,0	47,0	40,0	50,0	34,0	155,4	43,0-53,0	M10	30,0	1	G6.3	1,45	
	16	E341458341690	90,0	63,0	50,0	46,0	50,0	38,0	155,4	40,0-50,0	M10	30,0	1	G6.3	1,50	
	20	E341458342090	90,0	63,0	52,0	47,0	50,0	42,0	155,4	48,0-58,0	M10	30,0	1	G6.3	1,50	
	25	E3414583425105	105,0	78,0	58,0	50,0	70,0	58,0	170,4	47,0-57,0	M10	45,0	1	G6.3	2,30	
BT50 ADB	12	E3416583412105	105,0	67,0	47,0	40,0	50,0	32,0	206,8	58,0-68,0	M10	30,0	1	G6.3	3,98	
	20	E3416583420105	105,0	67,0	52,0	47,0	50,0	42,0	206,8	53,0-63,0	M10	30,0	1	G6.3	4,04	
	25	E3416583425110	110,0	72,0	58,0	50,0	70,0	58,0	211,8	52,0-62,0	M10	30,0	1	G6.3	4,78	
	32	E3416583432115	115,0	77,0	63,0	50,0	70,0	64,0	216,8	52,0-62,0	M10	30,0	1	G6.3	4,99	

For reduction sleeves and control gauges, see page(s) 307-308

Accessories

For Taper/ DCBN-DCBX	Locking key
BT40/ 6-8	H04-4
BT40/ 10	H04-4
BT40/ 12	H04-4
BT40/ 14-25	H04-4
BT50/ 12	H04-4
BT50/ 20-32	H04-4

Spare Parts

For Taper/ DCBN-DCBX	Plug	Press screw	Stop screw
BT40/ 6-8	-	950AF0810008	19LS0520A
BT40/ 10	-	950AF0810008	19LS0820A
BT40/ 12	950A0406	950AF0810008	19LS1020A
BT40/ 14-25	950A0406	950AF1010010	19LS1020A
BT50/ 12	950A0606	950AF0810008	19LS1020A
BT50/ 20-32	950A0606	950AF1010010	19LS1020A

Please check availability in current price and stock-list

EPB 5831 – Hydraulic chucks, slim

BT JIS B 6339-ADB



- Run-out 5 μm maximum at 3 x ØDCBN-DCBX

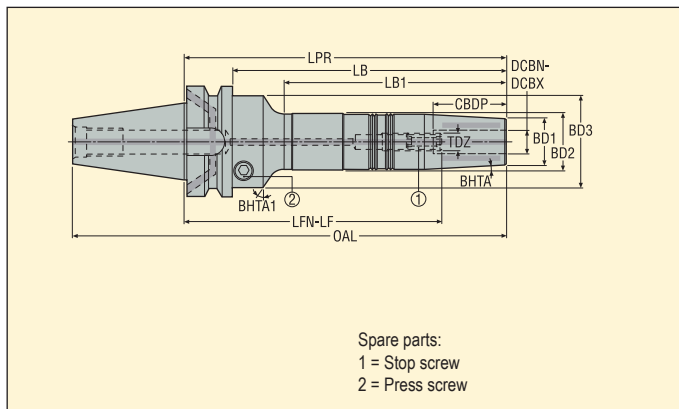

Machine side	Workpiece side	Designation	Dimensions in mm										TDZ	BHTA°	BHTA1°	RFID hole	Balancing	KG
			LPR	LB	LB1	CBDP	BD3	BD2	BD1	OAL	LFN-LF							
BT40 ADB	6	E3414583106150	150,0	123,0	93,3	37,0	53,0	26,0	21,0	215,4	123,0-113,0	M5	3,0	30,0	1	G6.3	1,70	
	6	E3414583106200	200,0	173,0	143,3	37,0	53,0	26,5	21,0	265,4	173,0-163,0	M5	3,0	30,0	1	G6.3	1,90	
	8	E3414583108150	150,0	123,0	93,3	37,0	53,0	28,0	23,0	215,4	123,0-113,0	M6	3,0	30,0	1	G6.3	1,70	
	8	E3414583108200	200,0	173,0	143,3	37,0	53,0	28,5	23,0	265,4	173,0-163,0	M6	3,0	30,0	1	G6.3	2,00	
	10	E3414583110150	150,0	123,0	93,3	42,0	53,0	30,0	25,0	215,4	118,0-108,0	M8	3,0	30,0	1	G6.3	1,80	
	10	E3414583110200	200,0	173,0	143,3	42,0	53,0	30,5	25,0	265,4	168,0-158,0	M8	3,0	30,0	1	G6.3	2,10	
	12	E3414583112150	150,0	123,0	93,3	47,0	53,0	32,0	27,0	215,4	113,0-103,0	M10	3,0	30,0	1	G6.3	1,80	
	12	E3414583112200	200,0	173,0	143,3	47,0	53,0	32,5	27,0	265,4	163,0-153,0	M10	3,0	30,0	1	G6.3	2,20	

For reduction sleeves and control gauges, see page(s) 307-308

Accessories

For DCBN-DCBX	Locking key
6	H04-4
8	H04-4
10	H04-4
12	H04-4

Spare Parts

For DCBN-DCBX	Plug	Press screw	Stop screw
6	950A0406	950AF1010010	19LS0516A
8	950A0406	950AF1010010	19LS0620A
10	950A0406	950AF1010010	19LS0820A
12	950A0406	950AF1010010	19LS1020A

Please check availability in current price and stock-list



- Run-out 10 µm maximum at 3 x ØDCBN-DCBX

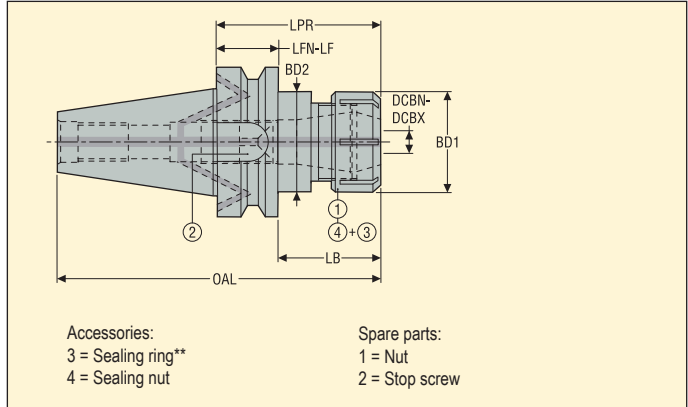

Machine side	Workpiece side	Capacity DCBN-DCBX mm	Designation	Chuck & Collet Size	Dimensions in mm					*	RFID hole	Balancing	KG
					LPR	BD2	BD1	OAL	LB				
BT40 ADB	0,5-10,0	E341456751670	ER 16	70,0	32,0	32,0	135,4	43,0	25,0-40,0	1	G2.5	1,12	
	0,5-10,0	E3414567516120	ER 16	120,0	32,0	32,0	185,4	93,0	75,0-90,0	1	G2.5	1,39	
	1,0-16,0	E341456752570	ER 25	70,0	42,0	42,0	135,4	43,0	2,0-32,0	1	G2.5	1,18	
	1,0-16,0	E3414567525120	ER 25	120,0	42,0	42,0	185,4	93,0	52,0-82,0	1	G2.5	1,67	
	2,0-20,0	E341456753270	ER 32	70,0	50,0	50,0	135,4	43,0	0,0-27,0	1	G2.5	1,27	
	2,0-20,0	E3414567532120	ER 32	120,0	50,0	50,0	185,4	93,0	33,0-77,0	1	G2.5	1,94	
	3,0-26,0	E3414567540100	ER 40	100,0	63,0	63,0	165,4	73,0	27,0-50,0	1	G2.5	1,97	
BT40 AD	3,0-26,0	E404156754075	ER 40*	75,0	63,0	63,0	140,4	48,0	3,0-25,0	*	1	G2.5	1,42
BT50 ADB	0,5-10,0	E3416567516120	ER 16	120,0	32,0	32,0	221,8	82,0	76,0-90,0	1	G2.5	3,84	
	1,0-16,0	E341656752590	ER 25	90,0	42,0	42,0	191,8	52,0	22,0-52,0	1	G2.5	3,83	
	2,0-20,0	E341656753290	ER 32	90,0	50,0	50,0	191,8	52,0	0,0-47,0	1	G2.5	3,92	
	2,0-20,0	E3416567532150	ER 32	150,0	50,0	50,0	251,8	112,0	29,0-107,0	1	G2.5	4,7	
	3,0-26,0	E3416567540100	ER 40	100,0	63,0	63,0	201,8	62,0	16,0-50,0	1	G2.5	4,31	

For ER extensions and ER collets, see page(s) 222, 314-315

* Chuck ER40/ LPR = 75 is type AD (E4041) without flange coolant through, instead type ADB (E3414)

Accessories**

For Taper/size	Seal nut	Socket	Spanner	Spanner 1	Torque key
BT40/ ER 16	08B587516IC	03ER032	03B587516	03BR032	03DYD010100
BT40/ ER 25	08B587525IC	03ER042	03B587525	03BR042	03DYD020200
BT40/ ER 32	08B587532IC	03ER050	03B587532	03BR050	03DYD020200
BT40/ ER 40	08B587540IC	03ER063	03B587540	03BR063	03DYD020200
BT40/ ER 40*	08B587540IC	03ER063	03B587540	03BR063	03DYD020200
BT50/ ER 16	08B587516IC	03ER032	03B587516	03BR032	03DYD010100
BT50/ ER 25	08B587525IC	03ER042	03B587525	03BR042	03DYD020200
BT50/ ER 32	08B587532IC	03ER050	03B587532	03BR050	03DYD020200
BT50/ ER 40	08B587540IC	03ER063	03B587540	03BR063	03DYD020200

Spare Parts

Nut	Plug	Stop screw
08B587516X	950A0406	19B58711
08B587525X	950A0406	19B58718
08B587532X	950A0406	19B58722
08B587540X	950A0406	19B58730
08B587540X	-	19B58730
08B587516X	950A0606	19B58711
08B587525X	950A0606	19B58718
08B587532X	950A0606	19B58722
08B587540X	950A0606	19B58730

Please check availability in current price and stock-list

** For ER sealing rings, see page(s) 320



• Run-out 15 µm maximum at 3 x ØDCBN-DCBX

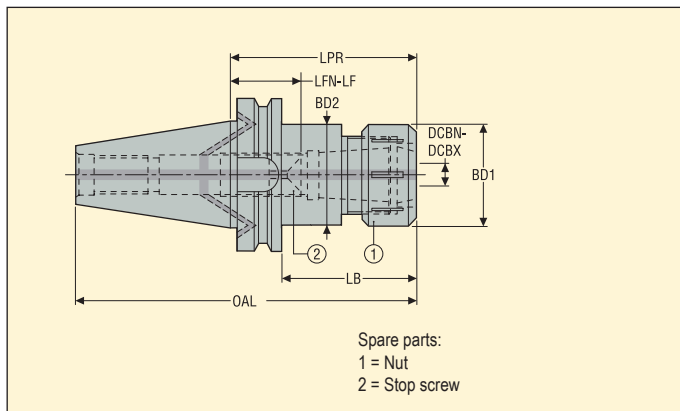

Machine side	Workpiece side	Capacity DCBN-DCBX mm	Designation	Chuck & Collet Size	Dimensions in mm					RFID hole	Balancing	KG
					LPR	BD1	BD2	OAL	LB			
BT40 ADB	4,0-32,0	E341458733290	OZ 32	90,0	72,0	63,0	155,4	63,0	15,0-25,0	1	PB	1,89
BT50 ADB	4,0-32,0	E341658733290	OZ 32	90,0	72,0	72,0	191,8	42,0	4,0-25,0	1	PB	4,18

For OZ collets, see page(s) 323

Accessories

For	Key
E341458733290	03B587332
E341658733290	03B587332

Spare Parts

For	Nut	Plug	Stop screw
E341458733290	08B587332	950A0406	19B58727
E341658733290	08B587332	950A0606	19B58735

Please check availability in current price and stock-list

EPB 5085 – Adjustable drill chucks

BT JIS B 6339-ADB

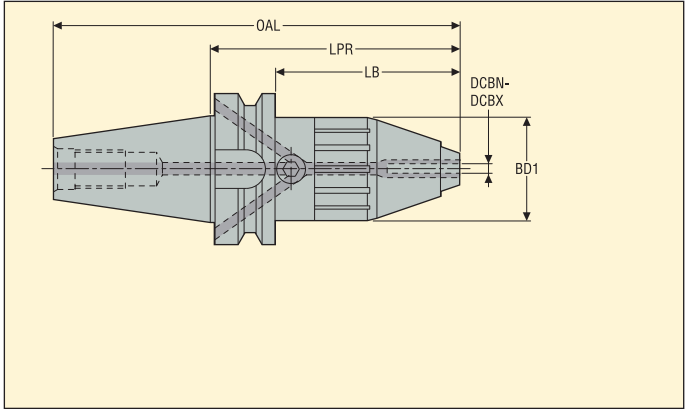

- Run-out 40 µm maximum at 2,5 x ØDCBN-DCBX

Machine side	Workpiece side	Capacity DCBN-DCBX mm	Designation	Dimensions in mm				RFID hole	Balancing	
				OAL	LPR	LB	BD1			
Taper										
BT40 ADB	1,0-13,0	E3414508513	169,4	104,0	77,0	43,0	1	PB	1,41	
BT50 ADB	2,5-16,0	E3416508516	232,8	131,0	93,0	56,0	1	PB	4,66	

Accessories

Spare Parts

For	Key
E3414508513	H06-4
E3416508516	H06-4

For	Plug
E3414508513	950A0406
E3416508516	950A0606

Please check availability in current price and stock-list

EPB 5023 – Greenstock blanks

BT JIS B 6339-ADB

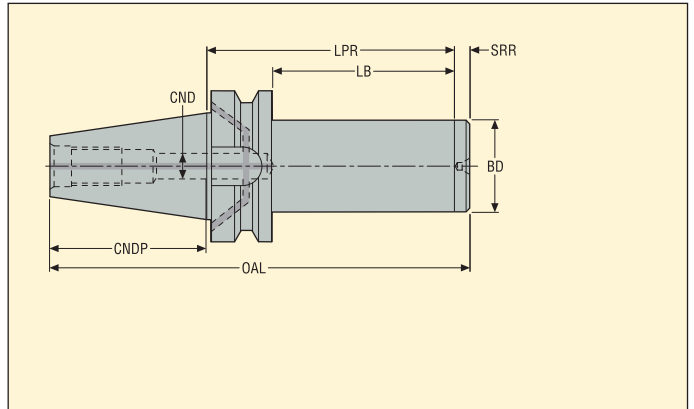

Machine side	Designation	Dimensions in mm							RFID hole	Balancing	
		LPR	LB	SRR	BD	CND	OAL	CNDP			
BT40 ADB	E3414502363250	250,0	215,0	8,0	63,0	10,0	323,4	85,0	1	PB	6,58
BT50 ADB	E3416502363315	315,0	277,0	8,0	63,0	21,0	424,8	130,0	1	PB	10,42
	E3416502395315	315,0	277,0	8,0	95,0	21,0	424,8	130,0	1	PB	20,00

Spare Parts

For Taper	Plug
BT40	950A0406
BT50	950A0606

Please check availability in current price and stock-list

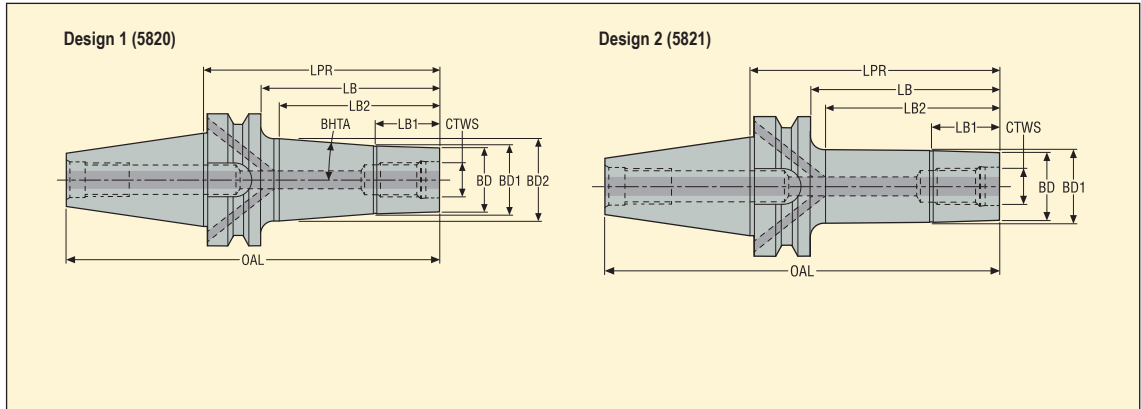

Machine side	Workpiece side	Designation	Dimensions in mm								BHTA°	Design	RFID hole	Balancing	KG
			LPR	LB	LB2	LB1	BD	BD2	BD1	OAL					
BT40 ADB	Combimaster CTWS	M6 E341458200660	60,0	33,0	25,0	10,0	11,0	14,5	11,7	125,4	5,3	1	1	G6.3	1,00
		M8 E341458210860	60,0	33,0	25,0	10,0	13,5	14,5	14,5	125,4	–	2	1	G6.3	1,00
		M10 E341458201085	85,0	58,0	50,0	15,0	18,5	24,5	19,7	150,4	3,9	1	1	G6.3	1,10
		M10 E3414582010135	135,0	108,0	100,0	20,0	18,5	27,5	19,7	200,4	2,8	1	1	G6.3	1,30
		M10 E341458211060	60,0	33,0	25,0	10,0	18,5	23,0	19,7	125,4	–	2	1	G6.3	1,00
		M12 E341458201240	40,0	13,0	5,0	5,0	23,0	24,7	24,7	105,4	9,6	1	1	G6.3	1,00
		M12 E341458201260	60,0	33,0	25,0	10,0	23,0	28,5	24,7	125,4	7,2	1	1	G6.3	1,10
		M12 E341458201285	85,0	58,0	50,0	20,0	23,0	30,0	24,7	150,4	5,0	1	1	G6.3	1,20
		M12 E3414582012110	110,0	83,0	75,0	25,0	23,0	31,5	24,7	175,4	3,9	1	1	G6.3	1,30
		M12 E3414582012135	135,0	108,0	100,0	30,0	23,0	33,0	24,7	200,4	3,4	1	1	G6.3	1,40
		M12 E341458211260	60,0	33,0	25,0	10,0	23,0	28,5	23,5	125,4	–	2	1	G6.3	1,10
		M12 E341458211285	85,0	58,0	50,0	20,0	23,0	30,0	23,5	150,4	–	2	1	G6.3	1,10
		M16 E341458201640	40,0	13,0	5,0	5,0	30,0	31,7	31,7	105,4	9,6	1	1	G6.3	1,10
		M16 E341458201660	60,0	33,0	25,0	10,0	30,0	35,5	31,7	125,4	7,2	1	1	G6.3	1,20
		M16 E341458201685	85,0	58,0	50,0	20,0	30,0	37,0	31,7	150,4	5,0	1	1	G6.3	1,30
		M16 E3414582016110	110,0	83,0	75,0	25,0	30,0	38,5	31,7	175,4	3,9	1	1	G6.3	1,50
		M16 E3414582016135	135,0	108,0	100,0	30,0	30,0	40,5	31,7	200,4	3,6	1	1	G6.3	1,70
		M16 E3414582016185	185,0	158,0	150,0	35,0	30,0	50,0	31,7	250,4	4,5	1	1	G6.3	2,40
		M20 E3414582020110	110,0	83,0	75,0	25,0	36,5	44,5	37,5	175,4	4,0	1	1	G6.3	1,70
		M20 E341458212045	45,0	18,0	10,0	5,0	36,5	37,0	37,0	110,4	–	2	1	G6.3	1,10
M20 E341458212085	85,0	58,0	50,0	20,0	36,5	37,0	37,0	150,4	–	2	1	G6.3	1,40		

Spare Parts

For Taper	Plug
BT40	950A0406

Please check availability in current price and stock-list

EPB 401 – Graflex® arbors

BT

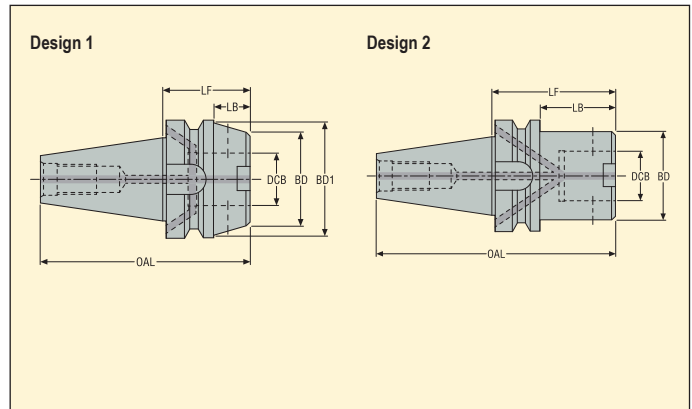

Machine side	Workpiece side Graflex		Designation	Dimensions in mm					Design	RFID hole	Balancing		
	Taper	Size		DCB mm	LF	LB	BD1	BD					OAL
BT40 ADB		G1	11	EM34144011190	90,0	63,0	20,0	20,0	155,4	2	1	G6.3	1,06
		G2	14	EM34144011440	40,0	13,0	25,0	25,0	105,4	2	1	G6.3	0,98
		G2	14	EM34144011490	90,0	63,0	25,0	25,0	155,4	2	1	G6.3	1,15
		G3	18	EM34144011840	40,0	13,0	62,0	32,0	105,4	1	1	G6.3	1,07
		G3	18	EM341440118100	100,0	73,0	32,0	32,0	165,4	2	1	G6.3	1,31
		G4	22	EM34144012245	45,0	18,0	62,0	40,0	110,4	1	1	G6.3	1,14
		G4	22	EM341440122100	100,0	73,0	40,0	40,0	165,4	2	1	G6.3	1,54
		G5	28	EM34144012845	45,0	18,0	62,0	50,0	110,4	1	1	PB	1,12
		G5	28	EM34144012880	80,0	53,0	50,0	50,0	145,4	2	1	PB	1,54
		G5	28	EM341440128120	120,0	93,0	50,0	50,0	185,4	2	1	PB	2,12
		G6	36	EM34144013650	50,0	0,0	63,0	63,0	115,4	2	1	PB	1,13
		G6	36	EM341440136120	120,0	0,0	63,0	63,0	185,4	2	1	PB	2,78

Accessories

For size	Locking key
G1	03H02
G2	03H025
G3	03H03
G4	03H04
G5	03H05
G6	03H06

Spare Parts

For size	Assembly screw	Plug
G1	90F1	950A0406
G2	90F2	950A0406
G3	90F3	950A0406
G4	90F4	950A0406
G5	90F5	950A0406
G6	90F6	950A0406

Please check availability in current price and stock-list

EPB 401 – Graflex® arbors

BT

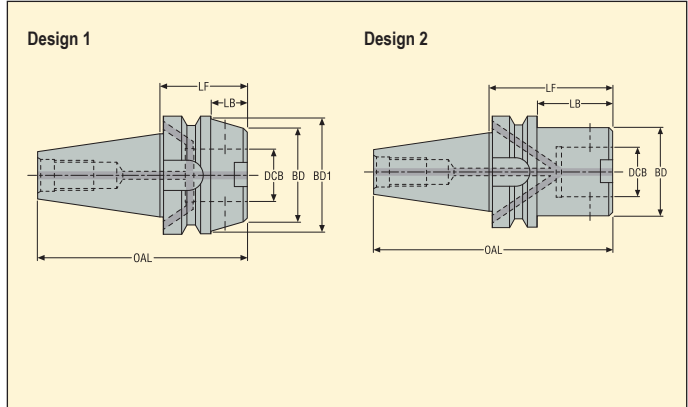

Machine side	Workpiece side Graflex		Designation	Dimensions in mm					Design	RFID hole	Balancing	KG
	Taper	Size		DCB mm	LF	LB	BD1	BD				
BT50 ADB	G2	14	EM341640114110	110,0	72,0	25,0	25,0	211,8	2	1	G6.3	3,70
	G3	18	EM34164011845	45,0	7,0	70,0	32,0	146,8	1	1	G6.3	3,58
	G3	18	EM341640118120	120,0	82,0	32,0	32,0	221,8	2	1	G6.3	3,90
	G4	22	EM34164012250	50,0	12,0	70,0	40,0	151,8	1	1	G6.3	3,66
	G4	22	EM341640122140	140,0	102,0	40,0	40,0	241,8	2	1	G6.3	4,36
	G5	28	EM34164012855	55,0	17,0	98,0	50,0	156,8	1	1	PB	3,97
	G5	28	EM341640128100	100,0	62,0	50,0	50,0	201,8	2	1	PB	4,22
	G5	28	EM341640128140	140,0	102,0	50,0	50,0	241,8	2	1	PB	4,80
	G6	36	EM34164013663	63,0	25,0	98,0	63,0	164,8	1	1	PB	4,20
	G6	36	EM341640136100	100,0	62,0	63,0	63,0	201,8	2	1	PB	4,60
	G6	36	EM341640136140	140,0	102,0	63,0	63,0	241,8	2	1	PB	5,54
	G7	46	EM34164014665	65,0	27,0	98,0	90,0	166,8	1	1	PB	4,30
	G7	46	EM341640146120	120,0	82,0	90,0	90,0	221,8	2	1	PB	6,80
	G7	46	EM341640146200	200,0	162,0	90,0	90,0	301,8	2	1	PB	10,70

Accessories

For size	Locking key
G2	03H025
G3	03H03
G4	03H04
G5	03H05
G6	03H06
G7	03H10

Spare Parts

For size	Assembly screw	Plug
G2	90F2	950A0606
G3	90F3	950A0606
G4	90F4	950A0606
G5	90F5	950A0606
G6	90F6	950A0606
G7	90F7	950A0606

Please check availability in current price and stock-list



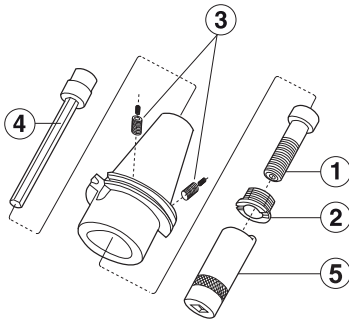



Accessories:
4 = Extension key
5 = Spanner

Spare parts:
1 = Centre screw
2 = Retaining nut
3 = Plugs (dowels)

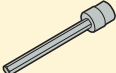
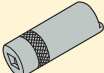
Accessories

For	Extension key	Spanner
		
C3-390.55	5680015-05	5680065-13
C3-390B.55	5680015-05	5680065-13
C3-390B.58	5680015-05	5680065-13
C4-390B.55	5680015-05	5680065-10
C4-390B.58	5680015-05	5680065-10
C5-390B.55	5680015-01	5680065-11
C5-390B.58	5680015-01	5680065-11
C6-390B.55	5680015-01	5680065-12
C6-390B.58	5680015-02	5680065-12
C8	5680015-02	5680065-12

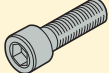
Spare Parts

For	Centre screw	Plug	Retaining nut
			
C3-390.55	5512063-10	-	5512091-04
C3-390B.55	5512063-10	564301701	5512091-04
C3-390B.58	5512063-10	564301702	5512091-04
C4-390B.55	5512063-07	564301701	5512091-03
C4-390B.58	5512063-07	564301702	5512091-03
C5-390B.55	5512063-08	564301701	5512091-01
C5-390B.58	5512063-08	564301702	5512091-01
C6-390B.55	5512063-13	564301701	5512091-02
C6-390B.58	5512063-09	564301702	5512091-02
C8	5512063-09	564301702	5512091-02

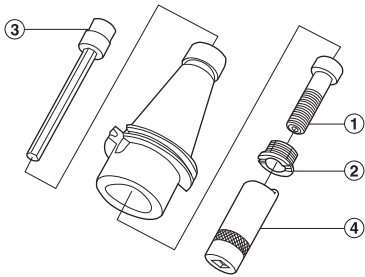



Accessories:
 3 = Extension key
 4 = Spanner

Spare parts:
 1 = Centre screw
 2 = Retaining nut

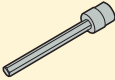
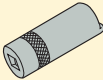
Accessories

For size	Extension key	Spanner
		
C5	5680015-01	5680065-11
C6	5680015-02	5680065-12
C8	5680015-02	5680065-12

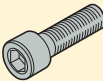
Spare Parts

For size	Centre screw	Retaining nut
		
C5	5512063-08	5512091-01
C6	5512063-09	5512091-02
C8	5512063-09	5512091-02

EPB 5525 – Shell mill holders, with through coolant channels

BT Taper-Face



- Direct run-out 5 µm maximum
- With coolant supply channels through the spigot

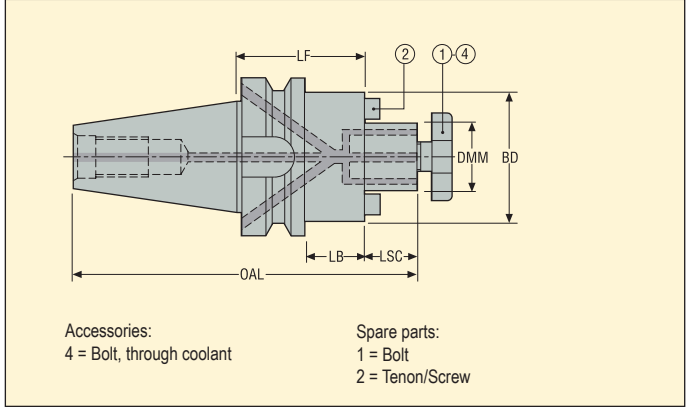

Machine side	Workpiece side	Designation	Dimensions in mm					RFID hole	Balancing	KG
			LF	BD	OAL	LB	LSC			
BT TF40 ADB	DMM mm									
	16	E321455251650	50,0	38,0	132,4	23,0	17,0	1	PB	1,20
	22	E321455252245	45,0	48,0	129,4	28,0	19,0	1	PB	1,30
	27	E321455252745	45,0	60,0	131,4	18,0	21,0	1	PB	1,50
	32	E321455253250	50,0	78,0	139,4	23,0	24,0	1	PB	1,90
	40	E321455254050	50,0	89,0	142,4	23,0	27,0	1	PB	2,20
BT TF50 ADB	22	E321655252255	55,0	48,0	175,8	17,0	19,0	1	PB	4,00
	27	E321655252755	55,0	60,0	177,8	17,0	21,0	1	PB	4,10
	32	E321655253255	55,0	78,0	180,8	17,0	24,0	1	PB	4,40
	40	E321655254055	55,0	89,0	183,8	17,0	27,0	1	PB	4,60

DMM 40, includes 4 threaded holes on the bearing face according to DIN 6357

Accessories

For	Bolt, through coolant	Spanner
E321455251650	5801608L	5811608
E321455252245	5802210L	5812210
E321455252745	5802712L	5812712
E321455253250	5803216L	5813216
E321455254050	5804020L	5814020
E321655252255	5802210L	5812210
E321655252755	5802712L	5812712
E321655253255	5803216L	5813216
E321655254055	5804020L	5814020

Spare Parts

For	Bolt	Plug	Screw	Tenon
E321455251650	5801608	950A0406	950D0312	16C10810164
E321455252245	5802210	950A0406	950D0416	16C11012206
E321455252745	5802712	950A0406	951D0512	16C11214243
E321455253250	5803216	950A0406	951D0516	16C2141421
E321455254050	5804020	950A0406	951D0616	16C2161621
E321655252255	5802210	950A0606	950D0416	16C11012206
E321655252755	5802712	950A0606	951D0512	16C11214243
E321655253255	5803216	950A0606	951D0516	16C2141421
E321655254055	5804020	950A0606	951D0616	16C2161621

Please check availability in current price and stock-list



- Direct run-out 3 µm maximum
- Weldon \varnothing DCBN-DCBX 16, 20, 25, 32 and 40 with ground face (Seco-Weldon compatible)

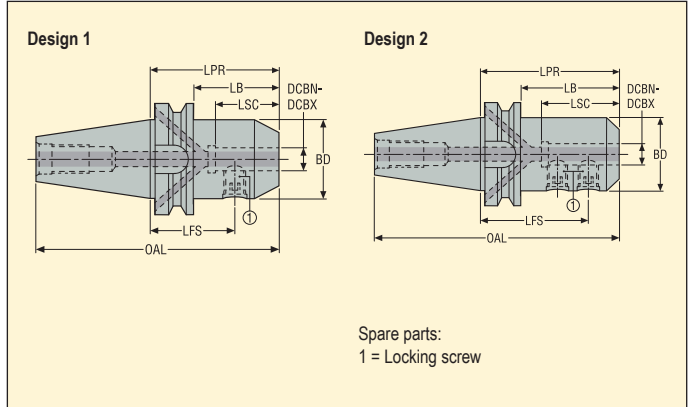

Machine side	Workpiece side	Designation	Dimensions in mm						Design	RFID hole	Balancing	KG
			LPR	LB	LSC	BD	OAL	LFS				
BT TF40 ADB	DCBN-DCBX mm											
	16	E32145841665	65,0	38,0	46,0	48,0	130,4	41,5	1	1	PB	1,40
	20	E32145842065	65,0	38,0	48,0	52,0	130,4	40,5	1	1	PB	1,50
	25	E32145842590	90,0	63,0	54,0	63,0	155,4	66,5	2	1	PB	2,20
	32	E321458432100	100,0	73,0	58,0	72,0	165,4	76,5	2	1	PB	2,70
	40	E321458440110	110,0	75,0	68,0	80,0	175,4	80,5	2	1	PB	3,20
BT TF50 ADB	25	E321658425100	100,0	62,0	54,0	63,0	201,8	76,5	2	1	PB	4,90
	32	E321658432105	105,0	67,0	58,0	72,0	206,8	81,5	2	1	PB	5,30
	40	E321658440115	115,0	77,0	67,0	80,0	216,8	88,5	2	1	PB	5,80
	50	E321658450130	130,0	92,0	78,0	100,0	231,8	95,5	2	1	PB	7,60

Spare Parts

For Taper/ DCBN-DCBX	Locking screw	Plug
BT TF40/ 16	951C1416	950A0406
BT TF40/ 20	951C1616	950A0406
BT TF40/ 25	951C1820	950A0406
BT TF40/ 32-40	951C2020	950A0406
BT TF50/ 25	951C1820	950A0606
BT TF50/ 32-40	951C2020	950A0606
BT TF50/ 50	951C2425	950A0606

Please check availability in current price and stock-list

EPB 5600 – Shrinkfit holders, reinforced

BT Taper-Face



- Reinforced design with wider front and tapered body
- Run-out 3 µm maximum at 3 x ØDCBN-DCBX
- With coolant supply channels towards the tool (plugged)
- Delivered with one stop screw

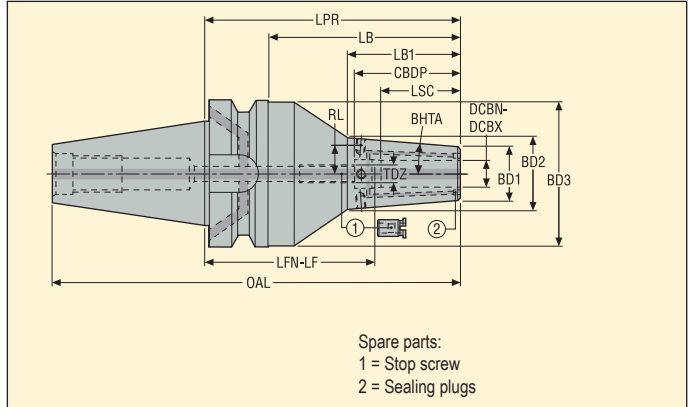

Machine side	Workpiece side	Designation	Dimensions in mm										TDZ	BHTA°	RL mm	RFID hole	Balancing	KG
			LPR*	LB	LB1	CBDP	LSC	BD3	BD2	BD1	OAL	LFN-LF						
BT TF40 ADB	12	E321456001270	70,0	43,0	43,0	47,5	34,0	-	35,2	27,0	135,4	24,0-36,0	M10x1	4,5	13,5	1	G2.5	1,20
	16	E321456001675	75,0	48,0	48,0	50,5	39,0	-	42,1	33,0	140,4	26,0-36,0	M12x1	4,5	17,0	1	G2.5	1,30
	20	E321456002075	75,0	48,0	48,0	52,5	41,0	-	53,1	44,0	140,4	24,0-34,0	M16x1	4,5	21,5	1	G2.5	1,60
	25	E321456002585	85,0	58,0	58,0	58,5	47,0	-	57,1	48,0	150,4	28,0-38,0	M16x1	4,5	25,0	1	G2.5	1,70
BT TF50 ADB	12	E3216560012100	100,0	62,0	62,0	47,5	34,0	-	35,2	27,0	201,8	54,0-66,0	M10x1	4,5	13,5	1	G2.5	4,10
	16	E3216560016100	100,0	62,0	62,0	50,5	39,0	-	42,1	33,0	201,8	51,0-61,0	M12x1	4,5	17,0	1	G2.5	4,20
	20	E3216560020100	100,0	62,0	62,0	52,5	41,0	-	53,1	44,0	201,8	49,0-59,0	M16x1	4,5	21,5	1	G2.5	4,50
	25	E3216560025100	100,0	62,0	62,0	58,5	47,0	-	57,1	48,0	201,8	43,0-53,0	M16x1	4,5	25,0	1	G2.5	4,50
	32	E3216560032105	105,0	67,0	67,0	62,5	51,0	-	57,1	48,0	206,8	44,0-54,0	M16x1	4,5	25,0	1	G2.5	4,50

* E321456001270, E321456001675, E321456002075, E321456002585, E3216560025100, E3216560032105: Extra-short holders requiring a dedicated Easyshrink® cooling contact bush type "5600 extra short", see page(s) 339

Accessories

For Taper/ DCBN-DCBX	Balancing screws
BT TF40/ 12	90ZQ01
BT TF40/ 16	90ZQ01
BT TF40/ 20-25	90ZQ01
BT TF50/ 12	90ZQ01
BT TF50/ 16	90ZQ01
BT TF50/ 20-25	90ZQ01
BT TF50/ 32	90ZQ01

Spare Parts

For Taper/ DCBN-DCBX	Plug	Sealing plugs	Stop screw
BT TF40/ 12	950A0406	90AI03	19BDR10165
BT TF40/ 16	950A0406	90AI03	19BDR12165
BT TF40/ 20-25	950A0406	90AI04	19BDR16165
BT TF50/ 12	950A0606	90AI03	19BDR10165
BT TF50/ 16	950A0606	90AI03	19BDR12165
BT TF50/ 20-25	950A0606	90AI04	19BDR16165
BT TF50/ 32	950A0606	90AI04	19BDR16165

Please check availability in current price and stock-list

EPB 401 – Graflex® arbors

BT Taper-Face

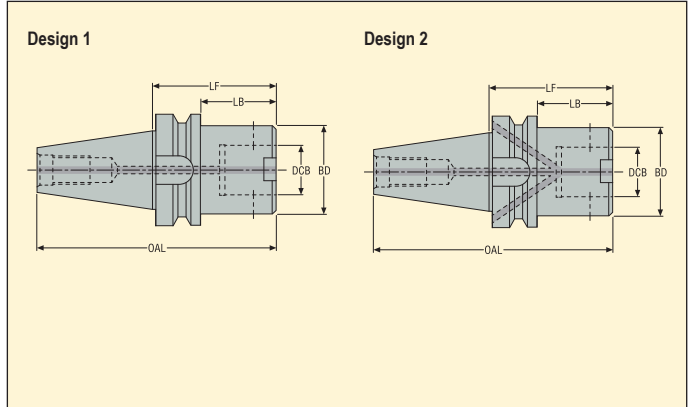

Machine side	Workpiece side Graflex		Designation	Dimensions in mm				Design	RFID hole	Balancing	KG
	Size	DCB mm		LF	LB	BD	OAL				
BT TF30 AD	G3	18	EM40024011850	50,0	28,0	32,0	98,4	1	0	G6.3	0,50
	G4	22	EM40024012250	50,0	28,0	40,0	98,4	1	0	G6.3	0,60
BT TF40 ADB	G4	22	EM321440122100	100,0	73,0	40,0	165,4	2	1	G6.3	1,60
	G5	28	EM321440128120	120,0	93,0	50,0	185,4	2	1	PB	2,10
	G6	36	EM321440136120	120,0	93,0	63,0	185,4	2	1	PB	2,80
BT TF50 ADB	G5	28	EM321640128140	140,0	102,0	50,0	241,8	2	1	PB	4,90
	G6	36	EM321640136140	140,0	102,0	63,0	241,8	2	1	PB	5,60
	G7	46	EM321640146200	200,0	162,0	90,0	301,8	2	1	PB	10,70

Accessories

For	Locking key
EM40024011850	03H03
EM40024012250	03H04
EM321440122100	03H04
EM321440128120	03H05
EM321440136120	03H06
EM321640128140	03H05
EM321640136140	03H06
EM321640146200	03H10

Spare Parts

For	Assembly screw	Plug
EM40024011850	90F3	–
EM40024012250	90F4	–
EM321440122100	90F4	950A0406
EM321440128120	90F5	950A0406
EM321440136120	90F6	950A0406
EM321640128140	90F5	950A0606
EM321640136140	90F6	950A0606
EM321640146200	90F7	950A0606

Please check availability in current price and stock-list



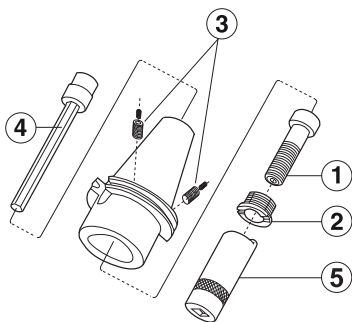



Accessories:
4 = Extension key
5 = Spanner

Spare parts:
1 = Centre screw
2 = Retaining nut
3 = Plugs (dowels)

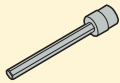
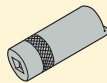
Accessories

For Taper/ size	Extension key	Spanner
		
BT TF30/ C3	5680015-05	5680065-13
BT TF30/ C4	5680015-05	5680065-10
BT TF40/ C4	5680015-05	5680065-10
BT TF40/ C5	5680015-01	5680065-11
BT TF40/ C6	5680015-01	5680065-12
BT TF50/ C4	5680015-05	5680065-10
BT TF50/ C5	5680015-01	5680065-11
BT TF50/ C6-C8	5680015-02	5680065-12

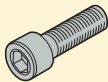
Spare Parts

For Taper/ size	Centre screw	Plug	Retaining nut
			
BT TF30/ C3	5512063-10	-	5512091-04
BT TF30/ C4	5512063-07	-	5512091-03
BT TF40/ C4	5512063-07	564301701	5512091-03
BT TF40/ C5	5512063-08	564301701	5512091-01
BT TF40/ C6	5512063-13	564301701	5512091-02
BT TF50/ C4	5512063-07	564301702	5512091-03
BT TF50/ C5	5512063-08	564301702	5512091-01
BT TF50/ C6-C8	5512063-09	564301702	5512091-02



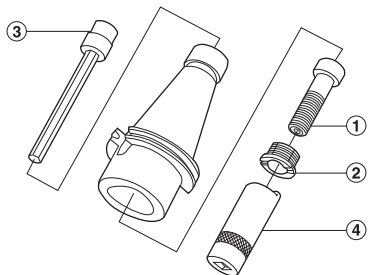



Accessories:
 3 = Extension key
 4 = Spanner

Spare parts:
 1 = Centre screw
 2 = Retaining nut

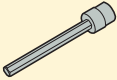
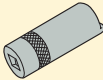
Accessories

For	Extension Key	Spanner
		
C3	5680015-05	5680065-13
C4	5680015-05	5680065-10
C5	5680015-01	5680065-11
C6-400	5680015-01	5680065-12
C6-500	5680015-02	5680065-12
C8	5680015-02	5680065-12

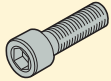
Spare Parts

For	Centre screw	Retaining nut
		
C3	5512063-10	5512091-04
C4	5512063-07	5512091-03
C5	5512063-08	5512091-01
C6-400	5512063-13	5512091-02
C6-500	5512063-09	5512091-02
C8	5512063-09	5512091-02

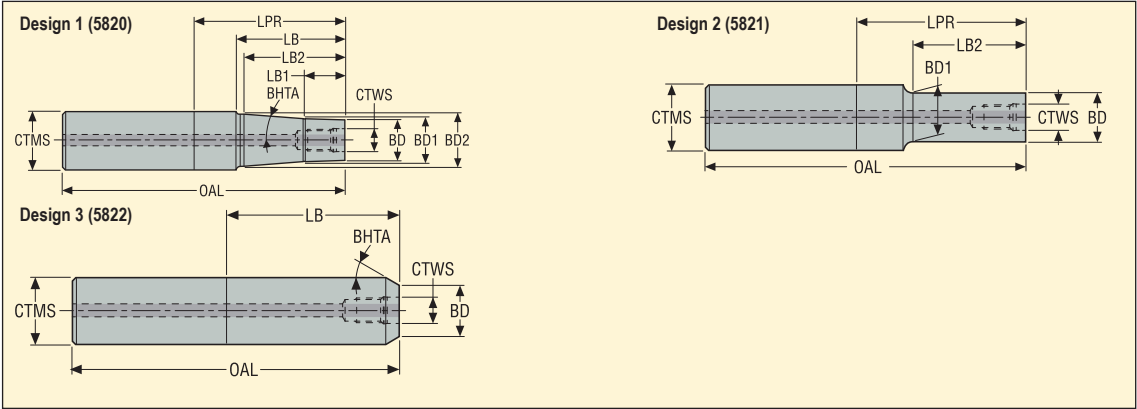

Machine side	Workpiece side	Designation	Dimensions in mm								BHTA°	Design	RFID hole	Balancing	KG
			LPR	LB	LB2	LB1	BD	BD2	BD1	OAL					
12	M6	BD01258220660	60,0	60,0	-	-	11,0	-	11,0	105,0	-	3	0	PB	0,10
	M6	BD01258220695E	95,0	95,0	-	-	11,0	-	11,0	140,0	30,0	3	0	PB	0,30
14	M8	BD01458220860	60,0	60,0	-	-	13,5	-	13,5	105,0	30,0	3	0	PB	0,20
	M8	BD01458220895E	95,0	95,0	-	-	13,5	-	13,5	140,0	30,0	3	0	PB	0,80
16	M8	BD01658220865	65,0	65,0	-	-	13,5	-	13,5	113,0	30,0	3	0	PB	0,20
	M8	BD016582208105E	105,0	105,0	-	-	13,5	-	13,5	153,0	30,0	3	0	PB	0,40
	M8	BD016582108105E	105,0	105,0	50,0	-	13,5	14,5	14,5	153,0	-	2	0	PB	0,40
18	M10	BD01858221070	70,0	70,0	-	-	18,0	-	18,0	118,0	30,0	3	0	PB	0,30
	M10	BD018582210125E	125,0	125,0	-	-	18,0	-	18,0	173,0	30,0	3	0	PB	0,80
20	M10	BD02058221075	75,0	75,0	-	-	18,5	-	18,5	125,0	30,0	3	0	PB	0,30
	M10	BD02058211040D	40,0	25,0	25,0	-	18,5	18,5	18,5	90,0	-	2	0	PB	0,50
	M10	BD020582110110	110,0	65,0	65,0	-	18,5	18,5	18,5	160,0	-	2	0	PB	0,40
	M10	BD020582110110D	110,0	65,0	65,0	-	18,5	18,5	18,5	160,0	-	2	0	PB	0,80
25	M12	BD02558221280	80,0	80,0	-	-	23,0	-	23,0	136,0	30,0	3	0	PB	0,50
	M12	BD025582112185E	185,0	85,0	85,0	-	23,0	23,5	23,5	241,0	-	2	0	PB	1,60
	M12	BD025582112185	185,0	85,0	85,0	-	23,0	23,5	23,5	241,0	-	2	0	PB	0,90
	M12	BD025582112185D	185,0	85,0	85,0	-	23,0	23,0	23,0	241,0	-	2	0	PB	1,70
32	M12	BD032582012100	100,0	65,0	65,0	25,0	23,0	31,0	24,7	160,0	4,5	1	0	PB	0,90
	M12	BD032582012240	240,0	145,0	145,0	30,0	23,0	31,0	24,7	300,0	1,6	1	0	PB	1,40
	M16	BD03258221695	95,0	95,0	-	-	30,0	-	30,0	155,0	30,0	3	0	PB	0,90
	M16	BD032582116100	100,0	65,0	65,0	-	30,0	30,0	30,0	160,0	-	2	0	PB	0,90
	M16	BD032582116100D	100,0	65,0	65,0	-	30,0	30,0	30,0	160,0	-	2	0	PB	2,00
	M16	BD032582116145D	145,0	110,0	110,0	-	30,0	30,0	30,0	205,0	-	2	0	PB	2,60
	M16	BD032582116240	240,0	145,0	145,0	-	30,0	30,0	30,0	300,0	-	2	0	PB	1,70
	M16	BD032582116240D	240,0	145,0	145,0	-	30,0	30,0	30,0	300,0	-	2	0	PB	3,80
40	M16	BD04058201690	90,0	65,0	65,0	25,0	30,0	39,0	31,7	160,0	5,2	1	0	PB	1,40
	M16	BD040582016135	135,0	110,0	110,0	35,0	30,0	39,0	31,7	205,0	2,8	1	0	PB	1,70
	M16	BD040582016230	230,0	145,0	145,0	35,0	30,0	39,0	31,7	300,0	1,9	1	0	PB	2,50

Please check availability in current price and stock-list

D = heavy metal, E = carbide

EPB 5801 – Shrinkfit holders

Cylindrical



- Run-out maximum: 3 μm at 3 x ØDCBN-DCBX and 3 μm direct
- Cylindrical shank CTMS with tolerance h5, compatible for Shrinkfit

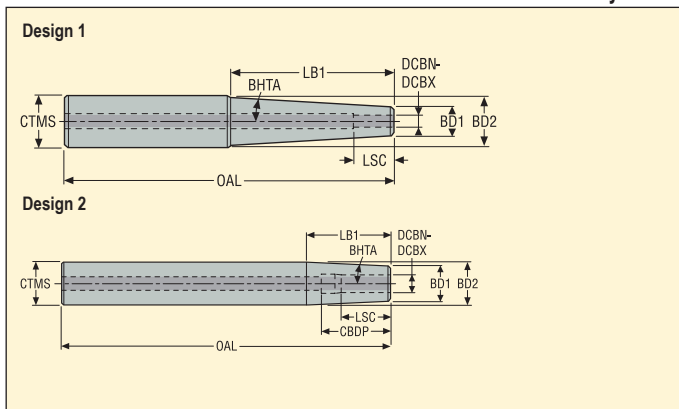

Machine side	Workpiece side	Designation	Dimensions in mm						Design	BHTA°	RFID hole	Balancing	KG
			LB1	BD2	BD1	OAL	CBDP	LSC					
Shank CTMS mm	DCBN-DCBX mm												
16	3	BD01658010352	51,0	16,0	9,0	100,0	–	13,0	1	3,0	0	PB	0,11
	3	BD016580103102	66,0	16,0	9,0	150,0	–	13,0	1	3,0	0	PB	0,18
	4	BD01658010452	51,0	16,0	10,0	100,0	–	15,0	1	3,0	0	PB	0,12
	4	BD016580104102	57,0	16,0	10,0	150,0	–	15,0	1	3,0	0	PB	0,19
	5	BD01658010552	47,0	16,0	11,0	100,0	–	18,0	1	3,0	0	PB	0,12
	6	BD01658010652	38,0	16,0	12,0	100,0	40,0	26,0	2	3,0	0	PB	0,13
	6	BD016580106102	38,0	16,0	12,0	150,0	40,0	26,0	2	3,0	0	PB	0,20
20	8	BD02058010850	38,0	20,0	16,0	100,0	44,0	30,0	2	3,0	0	PB	0,20
	8	BD020580108100	38,0	20,0	16,0	150,0	44,0	30,0	2	3,0	0	PB	0,32
	10	BD02058011050	19,0	20,0	18,0	100,0	45,0	32,0	2	3,0	0	PB	0,21
	10	BD020580110100	19,0	20,0	18,0	150,0	45,0	32,0	2	3,0	0	PB	0,31
	12	BD02058011250	50,0	20,0	20,0	100,0	46,0	34,0	2	3,0	0	PB	0,19
	12	BD020580112100	100,0	20,0	20,0	150,0	46,0	34,0	2	3,0	0	PB	0,30

Please check availability in current price and stock-list

EPB 402 – Graflex® extensions

Graflex®

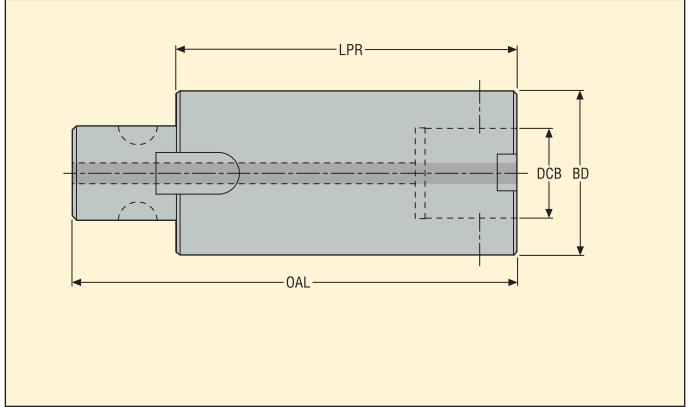

Machine side	Workpiece side		Designation	Dimensions in mm			RFID hole	Balancing	KG
	DCB mm	Graflex size		LPR	BD	OAL			
G0	8	G0	M402000	30,0	16,0	42,0	0	–	0,05
	8	G0	M402001	50,0	16,0	62,0	0	–	0,08
G1	11	G1	M402110	30,0	20,0	43,0	0	–	0,07
	11	G1	M402111	50,0	20,0	63,0	0	–	0,12
G2	14	G2	M402220	30,0	25,0	46,0	0	–	0,11
	14	G2	M402221	50,0	25,0	66,0	0	–	0,18
G3	18	G3	M402330	40,0	32,0	60,0	0	–	0,24
	18	G3	M402331	60,0	32,0	80,0	0	–	0,36
G4	22	G4	M402440	40,0	40,0	64,0	0	–	0,37
	22	G4	M402441	60,0	40,0	84,0	0	–	0,57
	22	G4	M402444	200,0	40,0	224,0	0	–	1,95

Accessories

Spare Parts

For DCB	Locking key
8	03H02
11	03H02
14	03H025
18	03H03
22	03H04

For DCB	Assembly screw	Tenon
8	90F0	90M0
11	90F1	90M1
14	90F2	90M2
18	90F3	90M3
22	90F4	90M4

Please check availability in current price and stock-list

EPB 402 – Graflex® extensions

Graflex®

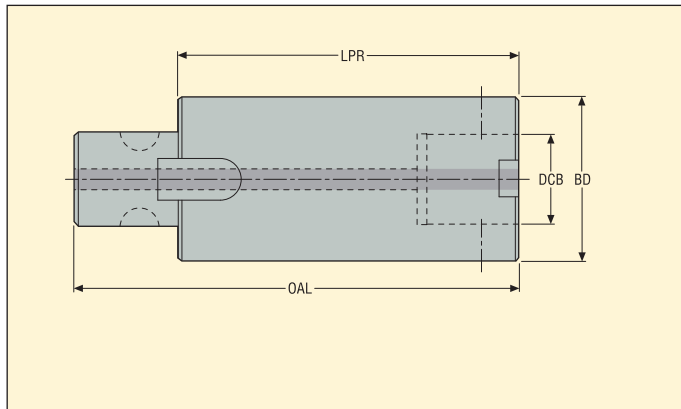

Machine side	Workpiece side		Designation	Dimensions in mm			RFID hole	Balancing	KG
	DCB mm	Graflex size		LPR	BD	OAL			
G5	28	G5	M402550	50,0	50,0	80,0	0	–	0,72
	28	G5	M402551	75,0	50,0	105,0	0	–	1,12
	28	G5	M402552	100,0	50,0	130,0	0	–	1,48
	28	G5	M402554	250,0	50,0	280,0	0	–	3,90
G6	36	G6	M402660	60,0	63,0	100,0	0	–	1,38
	36	G6	M402661	90,0	63,0	130,0	0	–	2,10
	36	G6	M402662	120,0	63,0	160,0	0	–	2,82
	36	G6	M402664	300,0	63,0	340,0	0	–	7,20
G7	46	G7	M402770	60,0	90,0	110,0	0	–	2,83
	46	G7	M402771	90,0	90,0	140,0	0	–	4,03
	46	G7	M402772	120,0	90,0	170,0	0	–	5,80
	46	G7	M402774	300,0	90,0	350,0	0	–	14,60

Accessories

For DCB	Locking key
28	03H05
36	03H06
46	03H10

Spare Parts

For DCB	Assembly screw	Tenon
28	90F5	90M5
36	90F6	90M6
46	90F7	90M7

Please check availability in current price and stock-list

EPB 403 – Graflex® reducers

Graflex®

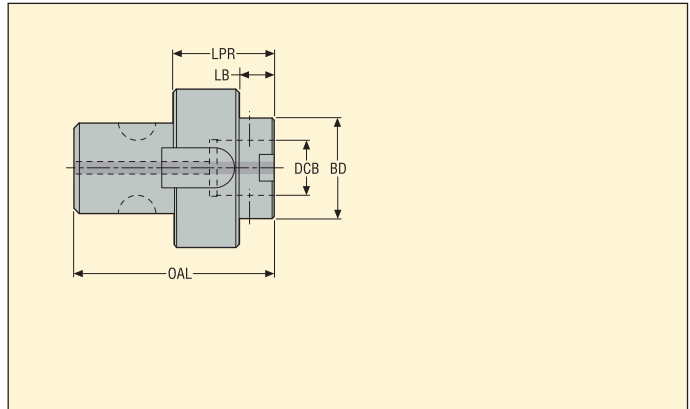

Machine side	Workpiece side		Designation	Dimensions in mm				RFID hole	Balancing	KG
	DCB mm	Graflex size		LPR	LB	BD	OAL			
G5	8	G0	M40350	40,0	20,0	16,0	70,0	0	–	0,47
	11	G1	M40351	40,0	20,0	20,0	70,0	0	–	0,49
	14	G2	M40352	40,0	20,0	25,0	70,0	0	–	0,49
	18	G3	M40353	40,0	20,0	32,0	70,0	0	–	0,52
	22	G4	M40354	40,0	20,0	40,0	70,0	0	–	0,55
G6	18	G3	M40363	40,0	14,0	32,0	80,0	0	–	0,98
	22	G4	M40364	40,0	14,0	40,0	80,0	0	–	0,97
	28	G5	M40365	45,0	19,0	50,0	85,0	0	–	1,04
G7	28	G5	M40375	50,0	24,0	50,0	100,0	0	–	2,08
	36	G6	M40376	55,0	29,0	63,0	105,0	0	–	2,23

Accessories

For	Locking key
M40350	03H02
M40351	03H02
M40352	03H025
M40353	03H03
M40354	03H04
M40363	03H03
M40364	03H04
M40365	03H05
M40375	03H05
M40376	03H06

Spare Parts

For	Assembly screw	Tenon
M40350	90F0	90M5
M40351	90F1	90M5
M40352	90F2	90M5
M40353	90F3	90M5
M40354	90F4	90M5
M40363	90F3	90M6
M40364	90F4	90M6
M40365	90F5	90M6
M40375	90F5	90M7
M40376	90F6	90M7

Please check availability in current price and stock-list

EPB 403 – Graflex® long reducers

Graflex®

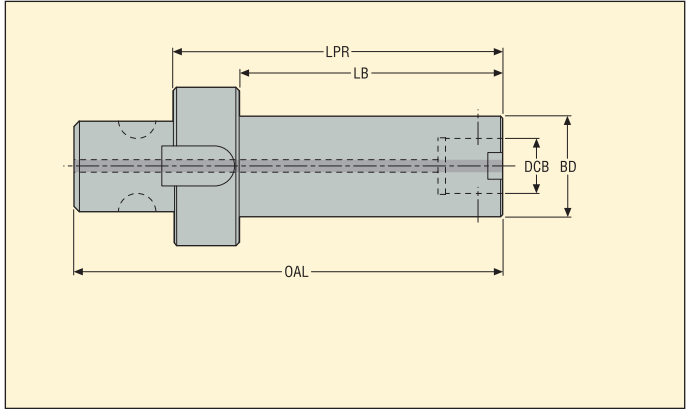

• For extra long reducers, see page(s) 235

Machine side	Workpiece side		Designation	Dimensions in mm				RFID hole	Balancing	KG
	DCB mm	Graflex size		LPR	LB	BD	OAL			
G5	8	G0	M40350070	70,0	50,0	16,0	100,0	0	–	0,51
	11	G1	M40351080	80,0	60,0	20,0	110,0	0	–	0,57
	14	G2	M40352100	100,0	80,0	25,0	130,0	0	–	0,71
	18	G3	M40353120	120,0	100,0	32,0	150,0	0	–	1,02
	22	G4	M40354150	150,0	130,0	40,0	180,0	0	–	1,62
G6	11	G1	M40361090	90,0	64,0	20,0	130,0	0	–	1,08
	14	G2	M40362110	110,0	84,0	25,0	150,0	0	–	1,23
	18	G3	M40363120	120,0	94,0	32,0	160,0	0	–	1,46
	22	G4	M40364150	150,0	124,0	40,0	190,0	0	–	2,07
	28	G5	M40365190	190,0	164,0	50,0	230,0	0	–	3,20

Accessories

Spare Parts

For	Locking key
M40350070	03H02
M40351080	03H02
M40352100	03H025
M40353120	03H03
M40354150	03H04
M40361090	03H02
M40362110	03H025
M40363120	03H03
M40364150	03H04
M40365190	03H05

For	Assembly screw	Tenon
M40350070	90F0	90M5
M40351080	90F1	90M5
M40352100	90F2	90M5
M40353120	90F3	90M5
M40354150	90F4	90M5
M40361090	90F1	90M6
M40362110	90F2	90M6
M40363120	90F3	90M6
M40364150	90F4	90M6
M40365190	90F5	90M6

Please check availability in current price and stock-list

EPB 5656 – Disc mill holders

Graflex®



- With adjustable slide rod
- Best suitable for Seco disc mill cutters Type A

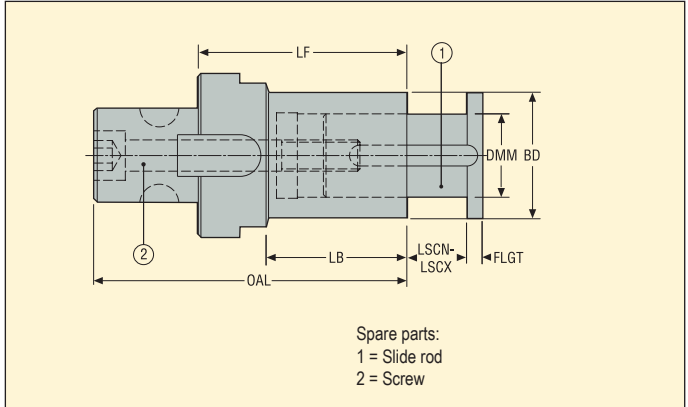

Machine side	Workpiece side	Designation	Dimensions in mm						RFID hole	Balancing	KG
			LF	BD	LB	OAL	FLGT	LSCN-LSCX			
G3	16	M56561816	50,0	28,0	36,0	70,0	3,0	0,0-10,0	0	PB	0,30
G4	22	M56562222	60,0	35,0	43,0	84,0	4,0	0,0-12,0	0	PB	0,56
G5	27	M56562827	65,0	42,0	45,0	95,0	5,0	0,0-15,0	0	PB	0,95
	32	M5656283212	80,0	48,0	60,0	110,0	6,0	0,0-24,0	0	PB	1,32
G6	40	M56563640	110,0	58,0	84,0	150,0	7,0	0,0-30,0	0	PB	2,68
G7	50	M56564650	130,0	72,0	104,0	180,0	8,0	0,0-32,0	0	PB	5,30

Spare Parts

For	Screw	Slide rod	Tenon
M56561816	950D0650	565616	90M3
M56562222	950D0860	565622	90M4
M56562827	950D1070	565627	90M5
M5656283212	950D1290	56563202	90M5
M56563640	950D16110	565640	90M6
M56564650	950D16120	565650	90M7

Please check availability in current price and stock-list

EPB 584 – Side lock holders, Weldon – DIN 1835 Form B/ DIN 6535 Form HB

Graflex®



- Weldon \varnothing DCBN-DCBX 16, 20, 25, 32 and 40 with ground face (Seco-Weldon compatible)

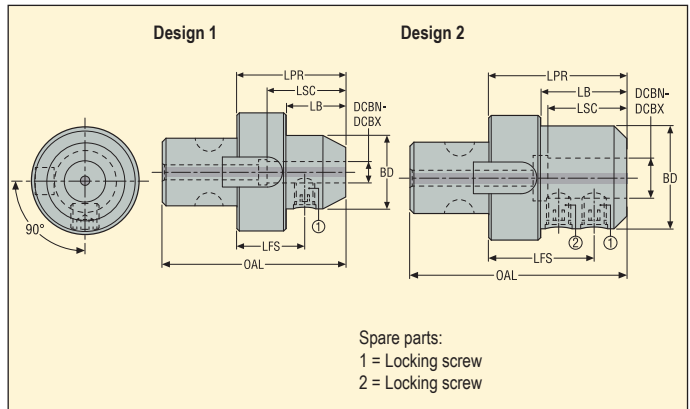

Machine side Graflex shank size	Workpiece side DCBN-DCBX mm	Designation	Dimensions in mm						Design	RFID hole	Balancing	KG
			LPR	LSC	LB	BD	OAL	LFS				
G5	6	M5842806	45,0	27,0	25,0	25,0	75,0	27,5	1	0	PB	0,51
	8	M5842808	45,0	30,0	25,0	28,0	75,0	27,5	1	0	PB	0,52
	10	M5842810	55,0	36,0	35,0	35,0	85,0	35,5	1	0	PB	0,65
	12	M5842812	60,0	43,0	40,0	42,0	90,0	38,0	1	0	PB	0,79
	14	M5842814	60,0	43,0	40,0	44,0	90,0	38,0	1	0	PB	0,81
	16	M5842816	65,0	46,0	45,0	48,0	95,0	41,5	1	0	PB	0,94
	18	M5842818	65,0	46,0	45,0	50,0	95,0	41,5	1	0	PB	0,96
	20	M5842820	65,0	48,0	45,0	52,0	95,0	40,5	1	0	PB	1,00
G6	16	M5843616	65,0	46,0	39,0	48,0	105,0	41,5	1	0	PB	1,34
	20	M5843620	65,0	48,0	39,0	52,0	105,0	40,5	1	0	PB	1,37
	25	M5843625	80,0	54,0	54,0	63,0	120,0	56,5	2	0	PB	1,95
	32	M5843632	80,0	58,0	54,0	72,0	120,0	56,5	2	0	PB	2,15
G7	40	M5844640	100,0	68,0	74,0	80,0	150,0	70,5	2	0	PB	4,00

Spare Parts

For	Locking screw 1	Locking screw 2	Tenon
M5842806	951C0610	–	90M5
M5842808	951C0810	–	90M5
M5842810	951C1012	–	90M5
M5842812	951C1216	–	90M5
M5842814	951C1216	–	90M5
M5842816	951C1416	–	90M5
M5842818	951C1416	–	90M5
M5842820	951C1616	–	90M5
M5843616	951C1416	–	90M6
M5843620	951C1616	–	90M6
M5843625	951C1820	951C1820	90M6
M5843632	951C2020	951C2017	90M6
M5844640	951C2020	951C2020	90M7

Please check availability in current price and stock-list

EPB 5675 – ER collet chucks - ISO 15488

Graflex®

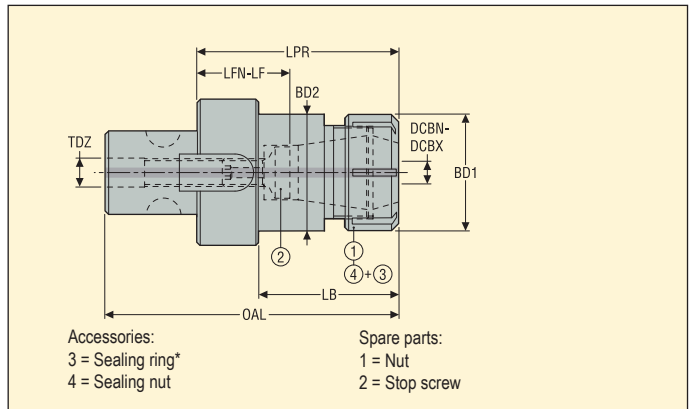

Machine side	Workpiece side	Designation	Chuck & Collet Size	Dimensions in mm						TDZ	RFID hole	Balancing	KG
				LPR	BD1	BD2	LB	OAL	LFN-LF				
G3	1,0-16,0	BM03056752570R	ER 25	70,0	35,0	32,0	-	90,0	30,0-32,0	M10	0	PB	0,35
	2,0-20,0	BM05056753275	ER 32	75,0	50,0	50,0	-	105,0	25,0-32,0	M12	0	PB	0,92
G5	1,0-16,0	BM05056752560	ER 25	60,0	42,0	42,0	40,0	90,0	17,0-22,0	M12	0	PB	0,66
	2,0-20,0	BM05056753275	ER 32	75,0	50,0	50,0	-	105,0	25,0-32,0	M12	0	PB	0,92
	3,0-26,0	BM06056754085	ER 40	85,0	63,0	63,0	-	125,0	26,0-35,0	M12	0	PB	1,73

For ER extensions and ER collets, see page(s) 222, 314-315

Accessories*

For	Seal nut	Socket	Spanner	Spanner 1	Torque key
BM03056752570R	-	03ER035	03B545025	03BR035	03DYD010100
BM05056752560	08B587525IC	03ER042	03B587525	03BR042	03DYD020200
BM05056753275	08B587532IC	03ER050	03B587532	03BR050	03DYD020200
BM06056752560	08B587525IC	03ER042	03B587525	03BR042	03DYD020200
BM06056753275	08B587532IC	03ER050	03B587532	03BR050	03DYD020200
BM06056754085	08B587540IC	03ER063	03B587540	03BR063	03DYD020200

Spare Parts

Nut	Stop screw	Tenon
08B587525M	19PM1016	90M3
08B587525X	19PM1216	90M5
08B587532X	19PM1220	90M5
08B587525X	19PM1216	90M6
08B587532X	19PM1220	90M6
08B587540X	19PM1225	90M6

Please check availability in current price and stock-list

* For ER sealing rings, see page(s) 320

EPB 5085 – Adjustable drill chucks

Graflex®

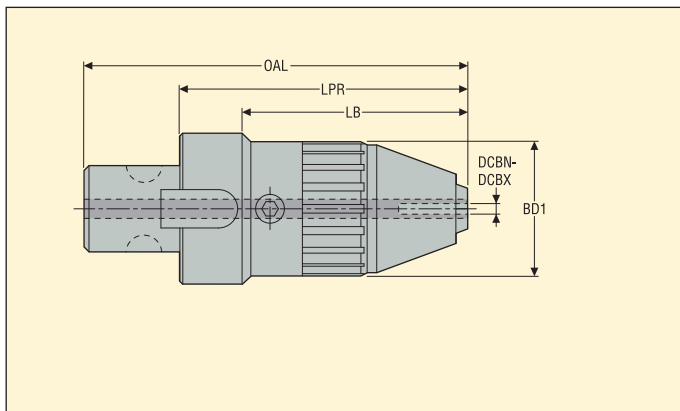

Machine side	Workpiece side	Designation	Dimensions in mm				RFID hole	Balancing	KG
			LPR	LB	BD1	OAL			
G5	Capacity								
	DCBN-DCBX mm								
	1,0-13,0	M50852813L	100,0	80,0	43,0	130,0	0	PB	0,92
G6	2,5-16,0	M50853616L	120,0	94,0	56,0	160,0	0	PB	2,01

Accessories

For	Key
M50852813L	H06-4
M50853616L	H06-4

Please check availability in current price and stock-list



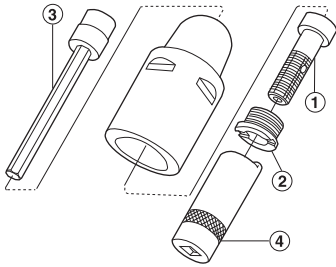



Accessories:
 3 = Extension key
 4 = Retaining nut spanner

Spare parts:
 1 = Centre screw
 2 = Retaining nut

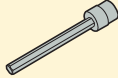
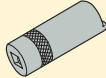
Accessories

For	Extension key	Spanner
		
C3	5680015-05	5680065-13
C4	5680015-05	5680065-10
C5	5680015-01	5680065-11
C6-63100	5680015-02	5680065-12
C6-63140	5680015-02	5680065-12
C8-80100	5680015-02	5680065-12
C8-80125	5680015-02	5680065-12

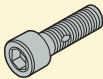
Spare Parts

For	Centre screw	Retaining nut
		
C3	5512067-01	5512091-04
C4	5512067-02	5512091-03
C5	5512067-03	5512091-01
C6-63100	5512067-04	5512091-02
C6-63140	5512067-04	5512091-02
C8-80100	5512067-04	5512091-02
C8-80125	5512067-04	5512091-02

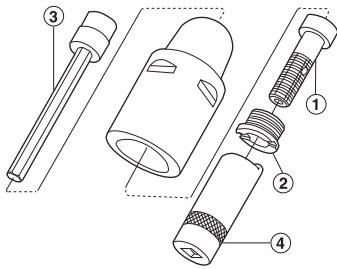



Accessories:
 3 = Extension key
 4 = Retaining nut spanner

Spare parts:
 1 = Centre screw
 2 = Retaining nut

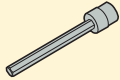
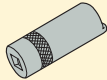
Accessories

For	Extension key	Spanner
		
C...-32	5680015-05	5680065-13
C...-40	5680015-05	5680065-10
C...-50	5680015-01	5680065-11
C...-63	5680015-02	5680065-12

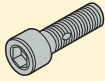
Spare Parts

For	Centre screw	Retaining nut
		
C...-32	5512067-01	5512091-04
C...-40	5512067-02	5512091-03
C...-50	5512067-03	5512091-01
C...-63	5512067-04	5512091-02

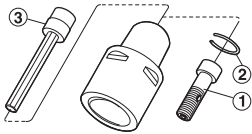



Accessories:
3 = Extension key

Spare parts:
1 = Centre screw
2 = Circlip

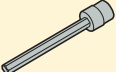
Accessories

For	Extension key
	
C3-391.01-32035	5680015-05
C4-391.01-40040	5680015-05
C5-391.01-50050	5680015-05
C6-391.01-63060	5680015-02
C8-391.01-80065	5680015-02

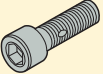
Spare Parts

For	Centre screw	Circlip
		
C3-391.01-32035	5512068-01	5545040-02
C4-391.01-40040	5512068-02	5545040-03
C5-391.01-50050	5512068-03	5545040-07
C6-391.01-63060	5512068-04	5545040-08
C8-391.01-80065	5512068-05	5545040-08

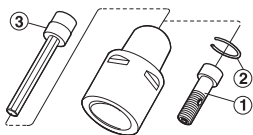



Accessories:
3 = Extension key

Spare parts:
1 = Centre screw
2 = Circlip

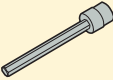
Accessories

For	Extension key
	
C5-391.02-32033A	5680015-05
C5-391.02-40040A	5680015-05
C6-391.02-32032	5680015-05
C6-391.02-40040	5680015-05
C6-391.02-50050A	5680015-01
C8-391.02-50045A	5680015-01
C8-391.02-63055A	5680015-02
C8-391.02R-63055A	5680015-02

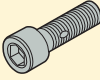
Spare Parts

For	Centre screw	Circlip
		
C5-391.02-32033A	5512068-01	5545040-02
C5-391.02-40040A	5512068-06	5545040-07
C6-391.02-32032	5512068-01	5545040-02
C6-391.02-40040	5512068-02	5545040-03
C6-391.02-50050A	5512068-07	5545040-08
C8-391.02-50045A	5512068-08	5545040-08
C8-391.02-63055A	5512068-05	5545040-08
C8-391.02R-63055A	5512068-05	5545040-08

EPB 5555/5556 – Steadyline®, vibration damping shell mill holders

Seco-Capto™



- With dynamic damping, ready to use

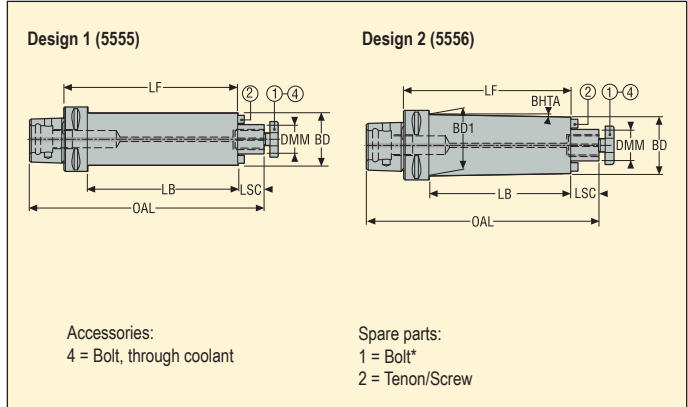

Machine side Seco-Capto™ shank	Workpiece side DMM mm	Designation	Dimensions in mm						Design	BHTA°	RFID hole	Balancing	KG
			LF	BD	BD1	OAL	LB	LSC					
C6	16	C6-391.5555-16160	160,0	38,0	38,0	215,0	135,0	17,0	1	–	1	PB	2,1
	22	C6-391.5555-22210	210,0	48,0	48,0	267,0	185,0	19,0	1	–	1	PB	3,6
	22	C6-391.5556-22260	260,0	48,0	60,0	317,0	235,0	19,0	2	1,3	1	PB	4,0
	27	C6-391.5555-27260	260,0	60,0	60,0	319,0	235,0	21,0	1	–	1	PB	6,8
C8	22	C8-391.5555-22210	210,0	48,0	48,0	277,0	177,0	19,0	1	–	1	PB	4,5
	22	C8-391.5556-22260	260,0	48,0	64,0	327,0	227,0	19,0	2	1,8	1	PB	6,4
	27	C8-391.5555-27260	260,0	60,0	60,0	329,0	227,0	21,0	1	–	1	PB	7,6
	27	C8-391.5556-27320	320,0	60,0	75,0	389,0	287,0	21,0	2	1,3	1	PB	10,6
	32	C8-391.5555-32330	330,0	78,0	78,0	402,0	297,0	24,0	1	–	1	PB	20,0
	40	C8-391.5555-40350	350,0	89,0	89,0	422,0	317,0	27,0	1	–	1	PB	19,0

DMM 40, includes 4 threaded holes on the bearing face according to DIN 6357

Accessories

For DMM	Bolt, through coolant	Spanner
16	5801608L	5811608
22	5802210L	5812210
27	5802712L	5812712
32	5803216L	5813216
40	5804020L	5814020

Spare Parts*

For DMM	Bolt	Screw	Tenon
16	5801608	951D0312	16C2080810A
22	5802210	951D0416	16C2101111
27	5802712	951D0516	16C2121214A
32	5803216	951D0516	16C2141421A
40	5804020	951D0616	16C2161621A

Please check availability in current price and stock-list

* These centre bolts are similar to the original delivered ones: check if lengths are suitable for the milling cutters used, therefore see in the Operating instructions sheet delivered with the holders or in page(s) 30

EPB 5525/5524 – Shell mill holders, with through coolant channels

Seco-Capto™

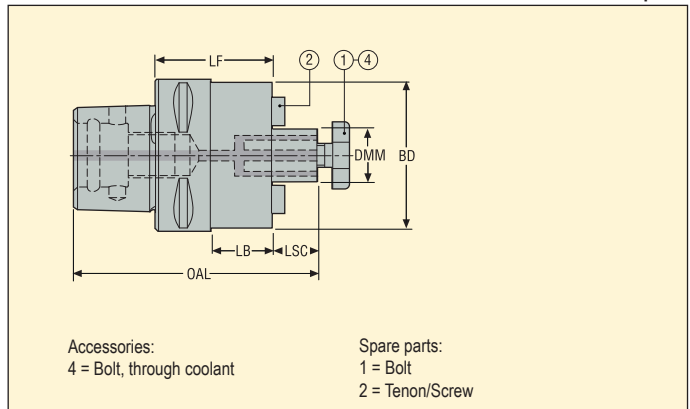

Machine side Seco-Capto™ shank	Workpiece side DMM mm	Designation	Dimensions in mm					*	RFID hole	Balancing	KG
			LF	BD	OAL	LB	LSC				
C3	16	C3-391.5525-16030	30,0	38,0	66,0	15,0	17,0		0	G6.3	0,27
C4	16	C4-391.5525-16035	35,0	38,0	76,0	12,0	17,0		0	G6.3	0,4
	22	C4-391.5525-22040	40,0	48,0	83,0	20,0	19,0		0	G6.3	0,58
C5	16	C5-391.5525-16035	35,0	38,0	82,0	12,0	17,0		1	G6.3	0,6
	22	C5-391.5525-22040	40,0	48,0	89,0	17,0	19,0		1	G6.3	0,76
	27	C5-391.5525-27040	40,0	60,0	91,0	20,0	21,0	*	1	G6.3	0,95
	27	C5-391.5524-27040	40,0	48,0	91,0	17,0	21,0	*	1	G6.3	0,8
C6	16	C6-391.5525-16035	35,0	38,0	90,0	10,0	17,0		1	G6.3	0,92
	22	C6-391.5525-22040	40,0	48,0	97,0	15,0	19,0		1	G6.3	1,09
	27	C6-391.5525-27040	40,0	60,0	99,0	15,0	21,0	*	1	G6.3	1,24
	32	C6-391.5525-32040	40,0	78,0	102,0	18,0	24,0		1	G6.3	1,6
	27	C6-391.5524-27040	40,0	48,0	99,0	15,0	21,0	*	1	G6.3	1,12
C8	27	C8-391.5525-27050	50,0	60,0	119,0	17,0	21,0	*	1	G6.3	2,29
	32	C8-391.5525-32050	50,0	78,0	122,0	17,0	24,0		1	G6.3	2,64
	40	C8-391.5525-40055	55,0	89,0	130,0	25,0	27,0		1	G6.3	3,06

* Diameter BD on type 5524 is smaller than on type 5525

Accessories

For DMM	Bolt, through coolant	Spanner
16	5801608L	5811608
22	5802210L	5812210
27/5524	5802712L	5812712
27/5525	5802712L	5812712
32	5803216L	5813216
40	5804020L	5814020

Spare Parts

For DMM	Bolt	Screw	Tenon
16	5801608	950D0312	16C10810164
22	5802210	950D0416	16C11012206
27/5524	5802712	951D0512	16C127
27/5525	5802712	951D0516	16C11214243
32	5803216	951D0516	16C2141421
40	5804020	951D0616	16C2161621

Please check availability in current price and stock-list

EPB 552 – Shell mill holders, small face – ISO 3937, without through coolant

Seco-Capto™

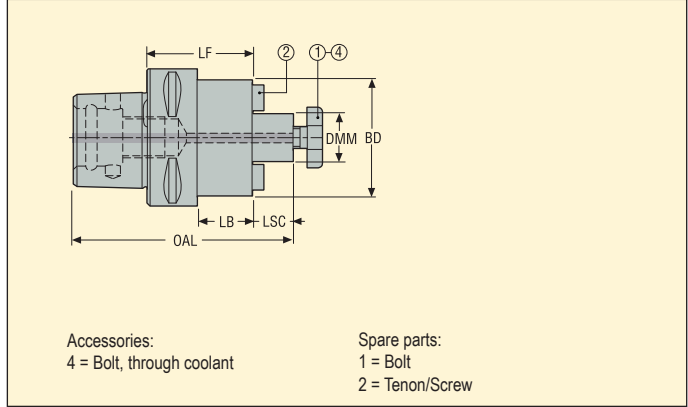

Machine side Seco-Capto™ shank	Workpiece side DMM mm	Designation	Dimensions in mm					RFID hole	Balancing	KG
			LF	BD	OAL	LB	LSC			
C3	16	C3-391.0552-16030	30,0	32,0	66,0	15,0	17,0	0	G6.3	0,2
C4	16	C4-391.0552-16032	32,0	32,0	73,0	9,0	17,0	0	G6.3	0,4
	22	C4-391.0552-22055	55,0	40,0	98,0	35,0	19,0	0	G6.3	0,7
C5	22	C5-391.0552-22070	70,0	40,0	119,0	47,0	19,0	1	G6.3	1,0
	27	C5-391.0552-27035	35,0	48,0	86,0	12,0	21,0	1	G6.3	0,8
C6	22	C6-391.0552-22035	35,0	40,0	92,0	10,0	19,0	1	G6.3	1,0
	27	C6-391.0552-27035	35,0	48,0	94,0	10,0	21,0	1	G6.3	1,1
	32	C6-391.0552-32035	35,0	58,0	97,0	10,0	24,0	1	G6.3	1,2
C8	27	C8-391.0552-27035	35,0	48,0	104,0	2,0	21,0	1	G6.3	1,9
	32	C8-391.0552-32035	35,0	58,0	107,0	2,0	24,0	1	G6.3	2,0
	40	C8-391.0552-40035	35,0	70,0	110,0	2,0	27,0	1	G6.3	2,2

Accessories

For DMM	Bolt, through coolant	Spanner
16	5801608L	5811608
22	5802210L	5812210
27	5802712L	5812712
32	5803216L	5813216
40	5804020L	5814020

Spare Parts

For DMM	Bolt	Screw	Tenon
16	5801608	950D0308	16C116
22	5802210	950D0410	16C122
27	5802712	951D0512	16C127
32	5803216	951D0514	16C132
40	5804020	951D0616	16C140

Please check availability in current price and stock-list

EPB 5657 – Disc mill holders

Seco-Capto™

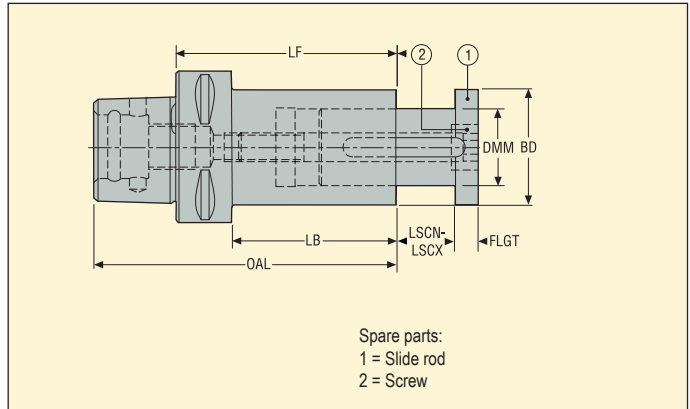

Machine side Seco-Capto™ shank	Workpiece side DMM mm	Designation	Dimensions in mm						RFID hole	Balancing	KG
			LF	BD	OAL	LB	LSCN-LSCX	FLGT			
C4	22	C4-391.5657-22075	75,0	35,0	99,0	52,0	0,0-12,0	4,0	0	PB	0,7
C5	27	C5-391.5657-27090	90,0	42,0	120,0	67,0	0,0-15,0	5,0	1	PB	1,2
	32	C5-391.5657-32120	120,0	48,0	150,0	97,0	0,0-24,0	6,0	1	PB	1,9
C6	22	C6-391.5657-22080	80,0	35,0	118,0	55,0	0,0-12,0	4,0	1	PB	1,2
	27	C6-391.5657-27090	90,0	42,0	128,0	65,0	0,0-15,0	5,0	1	PB	1,5
	32	C6-391.5657-32120	120,0	48,0	158,0	95,0	0,0-24,0	6,0	1	PB	2,2
	40	C6-391.5657-40150	150,0	58,0	188,0	125,0	0,0-30,0	7,0	1	PB	3,4
C8	27	C8-391.5657-27090	90,0	42,0	138,0	57,0	0,0-15,0	5,0	1	PB	2,4
	32	C8-391.5657-32120	120,0	48,0	168,0	87,0	0,0-24,0	6,0	1	PB	3,1
	40	C8-391.5657-40150	150,0	58,0	198,0	117,0	0,0-30,0	7,0	1	PB	4,3
	50	C8-391.5657-50200	200,0	72,0	248,0	167,0	0,0-32,0	8,0	1	PB	7,1
	60	C8-391.5657-60220	220,0	90,0	268,0	190,0	0,0-40,0	8,0	1	PB	11,2

Spare Parts

For DMM	Screw	Slide rod
22	19C565722	565722
27	19C565727	565727
32	950D1690	565732
40	19C565740	565740
50	19C565750	565750
60	19C565760	565760

Please check availability in current price and stock-list

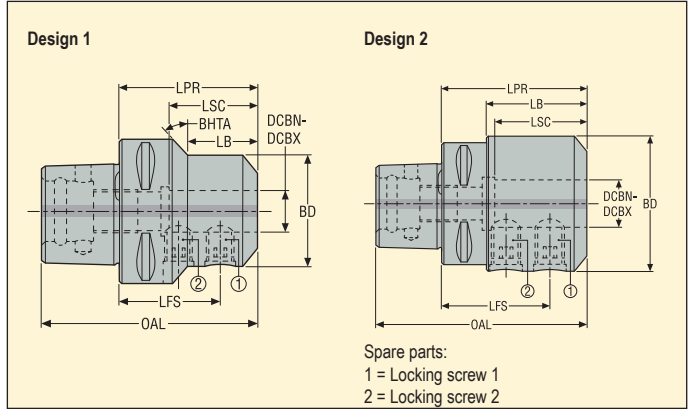

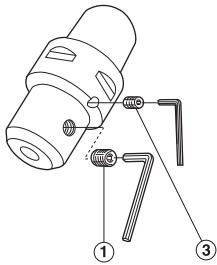

Machine side Seco-Capto™ shank	Workpiece side DCBN- DCBX mm	Designation	Dimensions in mm						Design	BHTA°	RFID hole	Balancing	KG
			LPR	LFS	BD	OAL	LB	LSC					
C3	6	C3-391.20-06045A	46,0	28,0	25,0	65,0	27,5	27,0	1	30,0	0	PB	0,3
	8	C3-391.20-08045A	46,0	28,0	28,0	65,0	29,0	30,0	1	45,0	0	PB	0,3
	10	C3-391.20-10050	50,0	30,0	35,0	69,0	32,0	36,0	2	–	0	PB	0,3
	12	C3-391.20-12055	55,0	32,5	42,0	74,0	47,0	40,0	2	–	0	PB	0,5
C4	6	C4-391.20-06050	50,0	32,0	25,0	74,0	25,5	27,0	1	30,0	0	PB	0,4
	8	C4-391.20-08050	50,0	32,0	28,0	74,0	26,5	30,0	1	45,0	0	PB	0,4
	10	C4-391.20-10050A	51,0	31,0	35,0	75,0	29,6	36,0	1	30,0	0	PB	0,5
	12	C4-391.20-12055A	56,0	33,5	42,0	80,0	53,0	43,0	2	–	0	PB	0,6
	14	C4-391.20-14055	55,0	32,5	44,0	79,0	55,0	43,0	2	–	0	PB	0,6
C5	6	C5-391.20-06050	50,0	32,0	25,0	80,0	25,5	27,0	1	20,0	0	PB	0,5
	8	C5-391.20-08050	50,0	32,0	28,0	80,0	26,0	30,0	1	20,0	0	PB	0,6
	10	C5-391.20-10055	55,0	35,0	35,0	85,0	27,5	36,0	1	45,0	0	PB	0,7
	12	C5-391.20-12060	60,0	37,5	42,0	90,0	36,0	43,0	1	45,0	0	PB	0,8
	14	C5-391.20-14060	60,0	37,5	44,0	90,0	37,0	43,0	1	45,0	0	PB	0,8
	18	C5-391.20-18060	60,0	36,0	50,0	90,0	40,0	46,0	1	–	0	PB	0,9
C6	6	C6-391.20-06055	55,0	37,0	25,0	93,0	25,0	27,0	1	22,0	0	PB	0,9
	8	C6-391.20-08055	55,0	37,0	28,0	93,0	26,0	30,0	1	22,0	0	PB	0,9
	10	C6-391.20-10060	60,0	40,0	35,0	98,0	30,0	36,0	1	30,0	0	PB	1,1
	12	C6-391.20-12060	60,0	37,5	42,0	98,0	33,0	43,0	1	25,0	0	PB	1,1
	14	C6-391.20-14060	60,0	37,5	44,0	98,0	33,5	43,0	1	25,0	0	PB	1,2
	18	C6-391.20-18065	65,0	41,0	50,0	103,0	39,0	46,0	1	30,0	0	PB	1,3
C8	6	C8-391.20-06070	70,0	52,0	25,0	118,0	27,0	27,0	1	25,0	0	PB	2,0
	8	C8-391.20-08070	70,0	52,0	28,0	118,0	28,0	30,0	1	25,0	0	PB	0,2
	10	C8-391.20-10070	70,0	50,0	35,0	118,0	29,5	36,0	1	25,0	0	PB	2,2
	12	C8-391.20-12070	70,0	47,5	42,0	118,0	31,0	43,0	1	25,0	0	PB	2,5
	14	C8-391.20-14070	70,0	47,5	44,0	118,0	31,6	43,0	1	25,0	0	PB	2,2
	18	C8-391.20-18070	70,0	46,0	50,0	118,0	33,0	46,0	1	25,0	0	PB	2,2
	50	C8-391.20-50120	120,0	85,0	100,0	168,0	90,0	78,0	2	–	0	PB	6,0

Please check availability in current price and stock-list



Spare parts:
 1 = Locking screw 1
 3 = Locking screw 2

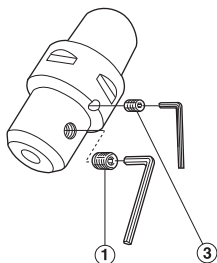

Spare Parts

For DCBN-DCBX	Locking screw 1	Locking screw 2
		
6	3214050-357	-
8	3214050-407	-
10	3214050-458	-
12	3214050-509	-
14	3214050-509	-
18	3214050-539	-
50	3214050-661	3214050-611



Spare parts:
 1 = Locking screw 1
 2 = Locking screw 2

Spare Parts

For	Locking screw 1	Locking screw 2
		
C4-391.0584-16055	951C1416	–
C5-391.0584-16060	951C1416	–
C5-391.0584-20060	951C1616	–
C5-391.0584-25080	951C1820	951C1820
C6-391.0584-16065	951C1416	–
C6-391.0584-20065	951C1616	–
C6-391.0584-25080	951C1820	951C1820
C6-391.0584-32090	951C2020	951C2020
C6-391.0584-40100	951C2020	951C2020
C8-391.0584-16070	951C1416	–
C8-391.0584-20070	951C1616	–
C8-391.0584-25080	951C1820	951C1820
C8-391.0584-32080	951C2020	951C2020
C8-391.0584-40110	951C2020	951C2020

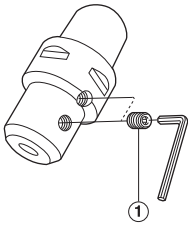

Spare parts:
1 = Locking screw

Spare Parts

For DCBN-DCBX	Locking screw
	
16	5514042-04
20	5514042-04
25	416.1-838
32	416.1-838
40	5514042-06

EPB 5603 – Shrinkfit holders, DIN type

Seco-Capto™



- Delivered with one stop screw

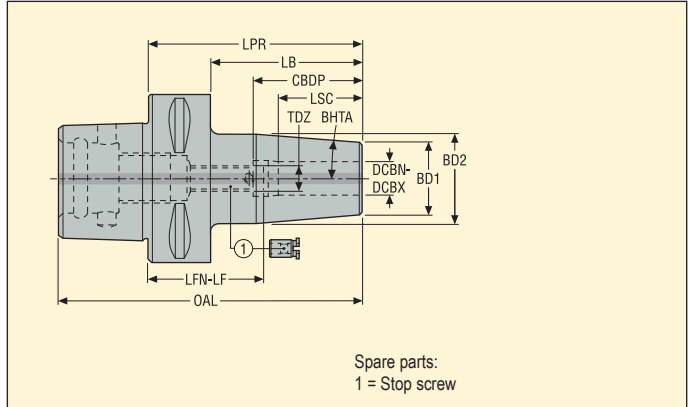

Machine side Seco-Capto™ shank	Workpiece side DCBN- DCBX mm	Designation	Dimensions in mm										RFID hole	Balancing	KG
			LPR	LB	CBDB	LSC	BD2	BD1	OAL	LFN-LF	TDZ	BHTA°			
C3	6	C3-391.5603-06065	65,0	50,0	37,5	22,0	27,0	21,0	84,0	29,0-43,0	M5x0.8	4,5	0	G6.3	0,3
	8	C3-391.5603-08065	65,0	50,0	37,5	26,0	27,0	21,0	84,0	29,0-39,0	M6x1	4,5	0	G6.3	0,3
	10	C3-391.5603-10070	70,0	55,0	42,5	31,0	32,0	24,0	89,0	29,0-39,0	M8x1	4,5	0	G6.3	0,4
	12	C3-391.5603-12070	70,0	55,0	47,5	34,0	32,0	24,0	89,0	24,0-36,0	M10x1	4,5	0	G6.3	0,4
C4	6	C4-391.5603-06075	75,0	55,0	37,5	22,0	27,0	21,0	99,0	39,0-53,0	M5x0.8	4,5	0	G6.3	0,5
	8	C4-391.5603-08075	75,0	55,0	37,5	26,0	27,0	21,0	99,0	39,0-49,0	M6x1	4,5	0	G6.3	0,5
	10	C4-391.5603-10075	75,0	55,0	42,5	31,0	32,0	24,0	99,0	34,0-44,0	M8x1	4,5	0	G6.3	0,5
	12	C4-391.5603-12075	75,0	55,0	47,5	34,0	32,0	24,0	99,0	29,0-41,0	M10x1	4,5	0	G6.3	0,5
	14	C4-391.5603-14080	80,0	60,0	47,5	34,0	34,0	27,0	104,0	34,0-46,0	M10x1	4,5	0	G6.3	0,6
	16	C4-391.5603-16080	80,0	60,0	50,5	39,0	34,0	27,0	104,0	31,0-41,0	M12x1	4,5	0	G6.3	0,6
C5	6	C5-391.5603-06075	75,0	55,0	37,5	22,0	27,0	21,0	105,0	39,0-53,0	M5x0.8	4,5	1	G6.3	0,7
	8	C5-391.5603-08075	75,0	55,0	37,5	26,0	27,0	21,0	105,0	39,0-49,0	M6x1	4,5	1	G6.3	0,6
	10	C5-391.5603-10075	75,0	55,0	42,5	31,0	32,0	24,0	105,0	34,0-44,0	M8x1	4,5	1	G6.3	0,7
	12	C5-391.5603-12075	75,0	55,0	47,5	34,0	32,0	24,0	105,0	29,0-41,0	M10x1	4,5	1	G6.3	0,7
	14	C5-391.5603-14080	80,0	60,0	47,5	34,0	34,0	27,0	110,0	34,0-46,0	M10x1	4,5	1	G6.3	0,7
	16	C5-391.5603-16080	80,0	60,0	50,5	39,0	34,0	27,0	110,0	31,0-41,0	M12x1	4,5	1	G6.3	0,7
	18	C5-391.5603-18080	80,0	60,0	50,5	39,0	42,0	33,0	110,0	31,0-41,0	M12x1	4,5	1	G6.3	0,9
	20	C5-391.5603-20085	85,0	65,0	52,5	41,0	42,0	33,0	115,0	34,0-44,0	M16x1	4,5	1	G6.3	0,9
	25	C5-391.5603-25090	90,0	70,0	58,5	47,0	53,0	44,0	120,0	33,0-43,0	M16x1	4,5	1	G6.3	1,2
C6	6	C6-391.5603-06080	80,0	58,0	37,5	22,0	27,0	21,0	118,0	44,0-58,0	M5x0.8	4,5	1	G6.3	1,0
	8	C6-391.5603-08080	80,0	58,0	37,5	26,0	27,0	21,0	118,0	44,0-54,0	M6x1	4,5	1	G6.3	1,0
	10	C6-391.5603-10080	80,0	58,0	42,5	31,0	32,0	24,0	118,0	39,0-49,0	M8x1	4,5	1	G6.3	1,1
	12	C6-391.5603-12080	80,0	58,0	47,5	34,0	32,0	24,0	118,0	34,0-46,0	M10x1	4,5	1	G6.3	1,1
	14	C6-391.5603-14085	85,0	63,0	47,5	34,0	34,0	27,0	123,0	39,0-51,0	M10x1	4,5	1	G6.3	1,1
	16	C6-391.5603-16085	85,0	63,0	50,5	39,0	34,0	27,0	123,0	36,0-46,0	M12x1	4,5	1	G6.3	1,1
	18	C6-391.5603-18085	85,0	63,0	50,5	39,0	42,0	33,0	123,0	36,0-46,0	M12x1	4,5	1	G6.3	1,3
	20	C6-391.5603-20085	85,0	63,0	52,5	41,0	42,0	33,0	123,0	34,0-44,0	M16x1	4,5	1	G6.3	1,2
	25	C6-391.5603-25090	90,0	68,0	58,5	47,0	53,0	44,0	128,0	33,0-43,0	M16x1	4,5	1	G6.3	1,5
	32	C6-391.5603-32095	95,0	73,0	62,5	51,0	53,0	44,0	133,0	34,0-44,0	M16x1	4,5	1	G6.3	1,4
C8	16	C8-391.5603-16090	90,0	60,0	50,5	39,0	34,0	27,0	138,0	41,0-51,0	M12x1	4,5	1	G6.3	2,1
	18	C8-391.5603-18090	90,0	60,0	50,5	39,0	42,0	33,0	138,0	41,0-51,0	M12x1	4,5	1	G6.3	2,2
	20	C8-391.5603-20090	90,0	60,0	52,5	41,0	42,0	33,0	138,0	39,0-49,0	M16x1	4,5	1	G6.3	2,1
	25	C8-391.5603-25090	90,0	60,0	58,5	47,0	53,0	44,0	138,0	33,0-43,0	M16x1	4,5	1	G6.3	2,4
	32	C8-391.5603-32090	90,0	60,0	62,5	51,0	53,0	44,0	138,0	29,0-39,0	M16x1	4,5	1	G6.3	2,3

Please check availability in current price and stock-list

No fine tune balancing threaded holes

Spare Parts

For DCBN-DCBX	Stop screw
	
6	19BDR05165
8	19BDR06165
10	19BDR08165
12-14	19BDR10165
16-18	19BDR12165
20-32	19BDR16165

EPB 5600 – Shrinkfit holders, reinforced

Seco-Capto™



- Reinforced design with wider front and tapered body
- Run-out maximum: 3 µm at 3 x ∅DCBN-DCBX and 3 µm direct
- With coolant supply channels towards the tool (plugged)
- Delivered with one stop screw

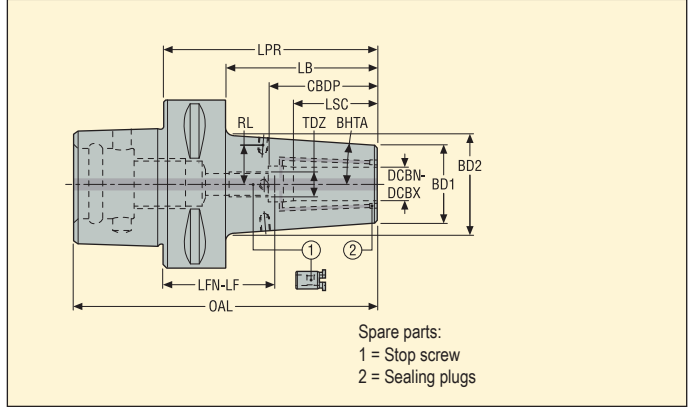

Machine side Seco-Capto™ shank	Workpiece side DCBN- DCBX mm	Designation	Dimensions in mm								TDZ	RL mm	BHTA°	RFID hole	Balancing	KG
			LPR*	LB	CBDP	LSC	BD2	BD1	OAL	LFN-LF						
C6	12	C6-391.5600-12080	80,0	58,0	47,5	34,0	35,2	27,0	118,0	34,0-46,0	M10x1	13,5	4,5	1	G6.3	1,2
	16	C6-391.5600-16085	85,0	63,0	50,5	39,0	42,1	33,0	123,0	36,0-46,0	M12x1	17,0	4,5	1	G6.3	1,3
	20	C6-391.5600-20085	85,0	63,0	52,5	41,0	53,1	44,0	123,0	34,0-44,0	M16x1	21,5	4,5	1	G6.3	1,6
	25	C6-391.5600-25090	90,0	68,0	58,5	47,0	57,1	48,0	128,0	33,0-43,0	M16x1	25,0	4,5	1	G6.3	1,8
C8	16	C8-391.5600-16095	95,0	65,0	50,5	39,0	42,1	33,0	143,0	46,0-56,0	M12x1	17,0	4,5	1	G6.3	2,3
	20	C8-391.5600-20095	95,0	65,0	52,5	41,0	53,1	44,0	143,0	44,0-54,0	M16x1	21,5	4,5	1	G6.3	2,6
	25	C8-391.5600-25100	100,0	70,0	58,5	47,0	57,1	48,0	148,0	43,0-53,0	M16x1	25,0	4,5	1	G6.3	2,8

* C6-391.5600-25090, C8-391.5600-25100: Extra-short holders requiring a dedicated Easyshrink® cooling contact bush type "5600 extra short", see page(s) 339

Accessories

For DCBN-DCBX	Balancing screws
12	90ZQ01
16	90ZQ01
20-25	90ZQ01

Spare Parts

For DCBN-DCBX	Sealing plugs	Stop screw
12	90AI03	19BDR10165
16	90AI03	19BDR12165
20-25	90AI04	19BDR16165

Please check availability in current price and stock-list

EPB 5600P Safe-Lock™ – Shrinkfit holders, reinforced and with tool pull-out protection

Seco-Capto™



- With Safe-Lock™ tool pull-out protection system
- Reinforced design of EPB 5600
- Run-out maximum: 3 μm at 3 x ØDCBN-DCBX and 3 μm direct
- With coolant supply channels towards the tool (plugged)
- Delivered with one stop screw fitted

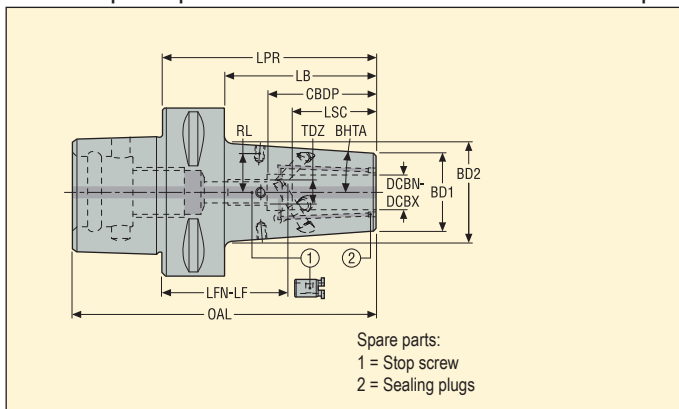

Machine side	Workpiece side	Designation	Dimensions in mm								TDZ	RL mm	BHTA°	RFID hole	Balancing	KG
			LPR*	LB	CDBP	LSC	BD2	BD1	OAL	LFN-LF						
C6	12	C6-391.5600-12080P	80,0	55,0	47,5	34,0	35,6	27,0	118,0	34,0-42,5	M10x1	13,5	4,5	1	G6.3	1,2
	16	C6-391.5600-16085P	85,0	60,0	50,5	39,0	42,4	33,0	123,0	36,0-44,0	M12x1	17,0	4,5	1	G6.3	1,3
	20	C6-391.5600-20085P	85,0	60,0	52,5	41,0	53,4	44,0	123,0	34,0-42,0	M16x1	21,5	4,5	1	G6.3	1,6
	25	C6-391.5600-25090P	90,0	65,0	58,5	47,0	58,2	48,0	128,0	33,0-41,0	M16x1	25,0	4,5	1	G6.3	1,8
C8	16	C8-391.5600-16095P	95,0	62,0	50,5	39,0	42,7	33,0	143,0	46,0-54,0	M12x1	17,0	4,5	1	G6.3	2,3
	20	C8-391.5600-20095P	95,0	62,0	52,5	41,0	53,7	44,0	143,0	44,0-52,0	M16x1	21,5	4,5	1	G6.3	2,6
	25	C8-391.5600-25100P	100,0	67,0	58,5	47,0	58,5	48,0	148,0	43,0-51,0	M16x1	25,0	4,5	1	G6.3	2,8

Accessories

For DCBN-DCBX	Balancing screws
12	90ZQ01
16	90ZQ01
20	90ZQ01
25	90ZQ01

Spare Parts

For DCBN-DCBX	Sealing plugs	Stop screw
12	90AI03	-
16	90AI03	-
20	90AI04	19BDR16165
25	90AI04	19BDR16165

Please check availability in current price and stock-list

(-) For DCBN-DCBX 12 and 16 mm, stop screw not removable/replaceable by the user, please request a repair process

EPB 5834 – Hydraulic chucks

Seco-Capto™

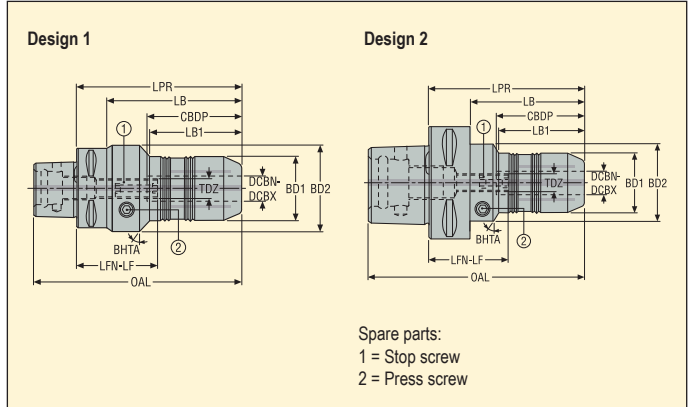

Machine side Seco-Capto™ shank	Workpiece side DCBN- DCBX mm	Designation	Dimensions in mm									TDZ	Design	BHTA°	RFID hole	Balancing	KG
			LPR	LB	CBDP	LB1	BD2	BD1	OAL	LFN-LF							
C4	12	C4-391.5834-12085	85,0	65,0	47,0	40,0	50,0	32,0	109,0	48,0-38,0	M10	1	30,0	0	G6.3	0,8	
C5	6	C5-391.5834-06065	65,0	42,0	38,0	23,0	50,0	26,0	95,0	37,0-27,0	M5	2	30,0	1	G6.3	0,8	
	8	C5-391.5834-08065	65,0	42,0	38,0	24,0	50,0	28,0	95,0	37,0-27,0	M5	2	30,0	1	G6.3	0,9	
	10	C5-391.5834-10075	75,0	52,0	42,0	34,0	50,0	30,0	105,0	43,0-33,0	M8	2	30,0	1	G6.3	0,8	
	12	C5-391.5834-12080	80,0	57,0	47,0	40,0	50,0	32,0	110,0	43,0-33,0	M10	2	30,0	1	G6.3	0,9	
	14	C5-391.5834-14080	80,0	57,0	47,0	40,0	50,0	34,0	110,0	43,0-33,0	M10	2	30,0	1	G6.3	0,9	
	16	C5-391.5834-16085	85,0	62,0	50,0	46,0	50,0	38,0	115,0	45,0-35,0	M10	2	30,0	1	G6.3	1,0	
	20	C5-391.5834-20085	85,0	62,0	52,0	47,0	50,0	42,0	115,0	43,0-33,0	M10	2	30,0	1	G6.3	1,0	
C6	25	C5-391.5834-25095	95,0	62,0	58,0	-	58,0	58,0	125,0	47,0-37,0	M10	1	-	1	G6.3	1,6	
	6	C6-391.5834-06065	65,0	40,0	38,0	40,0	50,0	26,0	103,0	37,0-27,0	M5	2	30,0	1	G6.3	1,1	
	8	C6-391.5834-08065	65,0	40,0	38,0	24,0	50,0	28,0	103,0	37,0-27,0	M5	2	30,0	1	G6.3	1,1	
	10	C6-391.5834-10075	75,0	50,0	42,0	34,0	50,0	30,0	113,0	43,0-33,0	M8	2	30,0	1	G6.3	1,2	
	12	C6-391.5834-12080	80,0	55,0	47,0	40,0	50,0	32,0	118,0	43,0-33,0	M10	2	30,0	1	G6.3	1,2	
	16	C6-391.5834-16085	85,0	60,0	50,0	46,0	50,0	38,0	123,0	45,0-35,0	M10	2	30,0	1	G6.3	1,3	
	20	C6-391.5834-20085	85,0	60,0	52,0	47,0	50,0	42,0	123,0	43,0-33,0	M10	2	30,0	1	G6.3	1,3	
C8	25	C6-391.5834-25095	95,0	70,0	58,0	70,0	58,0	58,0	133,0	47,0-37,0	M10	2	-	1	G6.3	0,6	
	32	C6-391.5834-32100	100,0	75,0	63,0	-	64,0	64,0	138,0	47,0-37,0	M10	1	-	1	G6.3	2,2	
C8	20	C8-391.5834-20095	95,0	62,0	52,0	52,0	50,0	42,0	143,0	53,0-43,0	M10	2	30,0	1	G6.3	2,4	

Accessories

For DCBN-DCBX	Locking key
12	H04-4
6-8	H04-4
10	H04-4
14-32	H04-4

Spare Parts

For DCBN-DCBX	Press screw	Stop screw
12	950AF0810008	19LS1016A
6-8	950AF0810008	19LS0512A
10	950AF0810008	19LS0816A
14-32	950AF1010010	19LS1016A

Please check availability in current price and stock-list
For reduction sleeves and control gauges, see page(s) 307-308

EPB 5831 – Hydraulic chucks, slim

Seco-Capto™



- Run-out 5 µm maximum at 3 x ØDCBN-DCBX

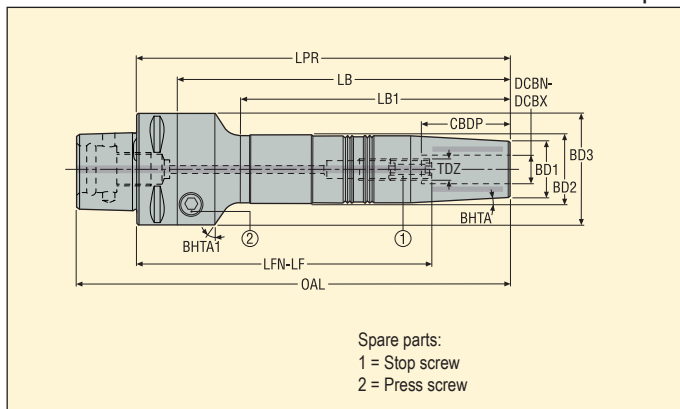

Machine side Seco-Capto™ shank	Workpiece side DCBN-DCBX mm	Designation	Dimensions in mm										TDZ	BHTA°	BHTA1°	RFID hole	Balancing	KG
			LPR	LB	LB1	CDBP	BD3	BD2	BD1	OAL	LFN-LF							
C5	6	C5-391.5831-06150	150,0	127,0	97,3	37,0	50,0	26,0	21,0	180,0	123,0-113,0	M5	3,0	30,0	1	G6.3	2,20	
	6	C5-391.5831-06200	200,0	177,0	147,3	37,0	50,0	26,5	21,0	230,0	173,0-163,0	M5	3,0	30,0	1	G6.3	1,40	
	8	C5-391.5831-08150	150,0	127,0	97,3	37,0	50,0	28,0	23,0	180,0	123,0-113,0	M6	3,0	30,0	1	G6.3	1,20	
	8	C5-391.5831-08200	200,0	177,0	147,3	37,0	50,0	28,5	23,0	230,0	173,0-163,0	M6	3,0	30,0	1	G6.3	1,50	
	10	C5-391.5831-10150	150,0	127,0	97,3	42,0	50,0	30,0	25,0	180,0	118,0-108,0	M8	3,0	30,0	1	G6.3	1,30	
	10	C5-391.5831-10200	200,0	177,0	147,3	42,0	50,0	30,5	25,0	230,0	168,0-158,0	M8	3,0	30,0	1	G6.3	1,60	
	12	C5-391.5831-12150	150,0	127,0	97,3	47,0	50,0	32,0	27,0	180,0	113,0-103,0	M10	3,0	30,0	1	G6.3	1,40	
	12	C5-391.5831-12200	200,0	177,0	147,3	47,0	50,0	32,5	27,0	230,0	163,0-153,0	M10	3,0	30,0	1	G6.3	1,70	

For reduction sleeves and control gauges, see page(s) 307-308

Accessories

For DCBN-DCBX	Locking key
6	H04-4
8	H04-4
10	H04-4
12	H04-4

Spare Parts

For DCBN-DCBX	Press screw	Stop screw
6	950AF1010010	19LS0516A
8	950AF1010010	19LS0620A
10	950AF1010010	19LS0820A
12	950AF1010010	19LS1020A

Please check availability in current price and stock-list

EPB 5672 – High precision collet chucks

Seco-Capto™

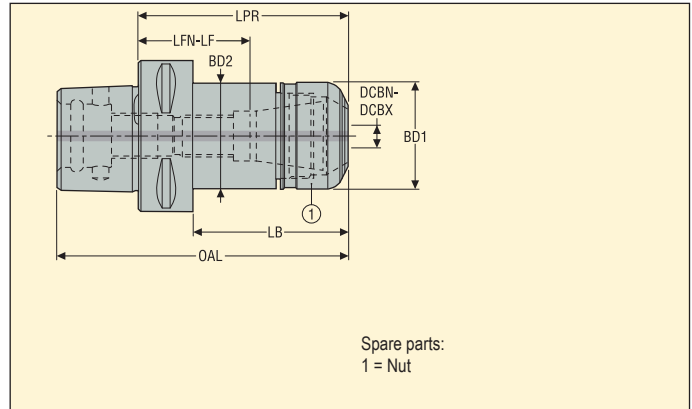

Machine side	Workpiece side	Capacity	Designation	Chuck & Collet Size	Dimensions in mm						RFID hole	Balancing	KG
					LPR	BD1	BD2	OAL	LB	LFN-LF*			
C3	0,5-10,0	C3-391.5672-16045R	HP 16R	45,0	24,0	24,0	64,0	30,0	14,0-15,0	**	0	G6.3	0,18
	0,5-10,0	C3-391.5672-16060	HP 16	60,0	30,0	30,0	79,0	45,0	29,0-30,0		0	G6.3	0,3
C4	0,5-10,0	C4-391.5672-16045R	HP 16R	45,0	24,0	24,0	69,0	25,0	14,0-15,0	**	0	G6.3	0,31
	0,5-10,0	C5-391.5672-16065	HP 16	65,0	30,0	30,0	95,0	45,0	34,0-35,0		1	G6.3	0,64
C5	1,0-16,0	C5-391.5672-25085	HP 25	85,0	40,0	40,0	115,0	65,0	29,0-47,0		1	G6.3	0,88
	0,5-10,0	C6-391.5672-16075	HP 16	75,0	30,0	30,0	113,0	53,0	44,0-45,0		1	G6.3	1,03
C6	1,0-16,0	C6-391.5672-25090	HP 25	90,0	40,0	40,0	128,0	68,0	34,0-52,0		1	G6.3	1,25
	1,0-16,0	C8-391.5672-25100	HP 25	100,0	40,0	40,0	148,0	70,0	44,0-62,0		1	G6.3	2,28
C8	2,0-20,0	C8-391.5672-32100	HP 32	100,0	50,0	50,0	148,0	70,0	44,0-48,0		1	G6.3	2,52

For ER HP collets type 5672, see page(s) 309-313, For chuck size HP 16R use the collet size ER HP 16

* LFN-LF setting length onto stop screw when possible, or total available setting length for chucks without thread for stop screw, ** Chuck without thread for stop screw

Accessories***

Spare Parts

For size	Socket	Spanner	Stop screw	Torque key	For size	Nut
HP 16	03ER030	03BR030	19B58711	03DYD010100	HP 16	08B567216
HP 16R	03ER024	03BR024	-	03DYD010100	HP 16R	08B567216R
HP 25	03ER040	03BR040	19B58718	03DYD020200	HP 25	08B567225
HP 32	03ER050	03BR050	19B58722	03DYD020200	HP 32	08B567232

Please check availability in current price and stock-list

*** When using a stop screw, its tapered contact onto the tool shank can increase the tool run-out defect, For tightening torques, see page(s) 41

EPB 5675 – ER collet chucks – ISO 15488

Seco-Capto™

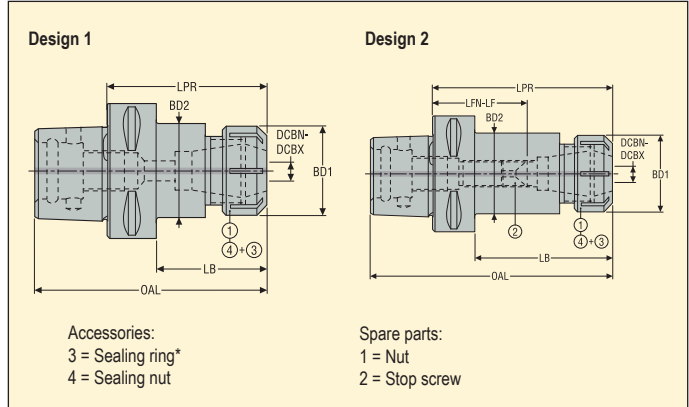

Machine side	Workpiece side		Designation	Dimensions in mm						Design	RFID hole	Balancing	KG
	Seco-Capto™ shank	Capacity DCBN-DCBX mm		LPR	BD1	BD2	OAL	LB	LFN-LF				
C3	ER 16	0,5-10,0	C3-391.5675-16045	45,0	32,0	32,0	64,0	27,0	-	1	0	G6.3	0,2
	C4	ER 25	1,0-16,0	C4-391.5675-25052	52,0	42,0	42,0	76,0	29,0	-	1	0	G6.3
C4	ER 32	2,0-20,0	C4-391.5675-32054	54,0	50,0	50,0	78,0	-	-	1	0	G6.3	0,4
	C5	ER 25	1,0-16,0	C5-391.5675-25055	55,0	42,0	42,0	85,0	32,0	-	1	1	G6.3
C5	ER 25	1,0-16,0	C5-391.5675-25100	100,0	42,0	42,0	130,0	77,0	31,0-62,0	2	1	G6.3	1,0
	ER 32	2,0-20,0	C5-391.5675-32057	57,0	50,0	50,0	87,0	32,0	-	1	1	G6.3	0,7
C6	ER 16	0,5-10,0	C6-391.5675-16100	100,0	32,0	32,0	138,0	75,0	52,0-68,0	2	1	G6.3	1,2
	ER 25	1,0-16,0	C6-391.5675-25060	60,0	42,0	42,0	98,0	35,0	-	1	1	G6.3	1,0
	ER 25	1,0-16,0	C6-391.5675-25100	100,0	42,0	42,0	138,0	75,0	31,0-62,0	2	1	G6.3	1,4
	ER 25	1,0-16,0	C6-391.5675-25130	130,0	42,0	42,0	168,0	105,0	61,0-92,0	2	1	G6.3	1,7
	ER 25	1,0-16,0	C6-391.5675-25160	160,0	42,0	42,0	198,0	135,0	91,0-122,0	2	1	G6.3	2,0
	ER 32	2,0-20,0	C6-391.5675-32060	60,0	50,0	50,0	98,0	35,0	-	1	1	G6.3	1,0
	ER 32	2,0-20,0	C6-391.5675-32100	100,0	50,0	50,0	138,0	78,0	32,0-60,0	2	1	G6.3	1,6
	ER 32	2,0-20,0	C6-391.5675-32130	130,0	50,0	50,0	168,0	108,0	62,0-90,0	2	1	G6.3	2,0
C8	ER 40	3,0-26,0	C6-391.5675-40065	65,0	63,0	63,0	103,0	45,0	-	1	1	G6.3	1,2
	ER 32	2,0-20,0	C8-391.5675-32070	70,0	50,0	50,0	118,0	37,0	23,0-30,0	2	1	G6.3	2,1
		2,0-20,0	C8-391.5675-32160	160,0	50,0	50,0	208,0	130,0	92,0-120,0	2	1	G6.3	3,3
ER 40	3,0-26,0	C8-391.5675-40070	70,0	63,0	63,0	118,0	37,0	23,0-30,0	2	1	G6.3	2,1	

Accessories*

For size	Seal nut	Socket	Spanner	Spanner 1	Torque key
ER 16	08B587516IC	03ER032	03B587516	03BR032	03DYD010100
ER 25	08B587525IC	03ER042	03B587525	03BR042	03DYD020200
ER 32	08B587532IC	03ER050	03B587532	03BR050	03DYD020200
ER 40	08B587540IC	03ER063	03B587540	03BR063	03DYD020200

Spare Parts

Nut	Stop screw
08B587516X	19B58711
08B587525X	19B58718
08B587532X	19B58722
08B587540X	19B58730

Please check availability in current price and stock-list

* For ER sealing rings, see page(s) 320, For ER collets, see page(s) 314-315

EPB 5867 – Tapping chucks for synchronized tapping, with micro-compensation

Seco-Capto™



- Inbuilt axial micro flexure ($\pm 0,5$ mm) prevents from tap stress
- Tap fitting based on ER tapping collets with square drive
- Maximum coolant pressure 80 bar

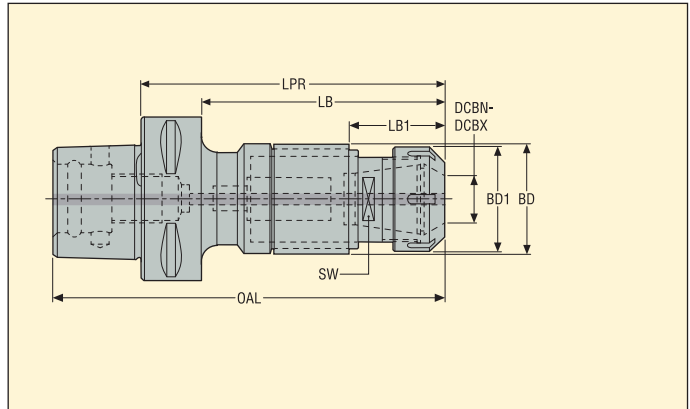

Machine side	Workpiece side		Designation	Dimensions in mm							*	RFID hole	Balancing	KG	
	Seco-Capto™ shank	Size		Tapping range	LPR	LB2	LB1	BD	BD1	OAL					SW
C4		ER 11	M2-M5	C4-391.5867-11080	80,0	60,0	24,1	23,5	18,7	104,0	12,7		0	PB	0,4
		ER 20	M4-M12	C4-391.5867-20102	102,2	82,0	40,3	35,0	33,7	126,2	22,0		0	PB	0,7
		ER 25	M8-M20	C4-391.5867-25122	121,6	101,6	42,1	44,0	42,0	145,6	28,0		0	PB	1,1
C5		ER 20	M4-M12	C5-391.5867-20103	102,7	82,7	40,3	35,0	33,7	132,7	22,0		1	PB	0,9
		ER 25	M8-M20	C5-391.5867-25122	122,1	102,1	42,1	44,0	42,0	152,1	28,0		1	PB	1,3
		ER 40	M16-M33	C5-391.5867-40154	154,0	134,0	52,0	62,0	62,7	184,0	39,7		1	PB	2,8
C6		ER 20	M4-M12	C6-391.5867-20105	104,7	82,7	40,3	35,0	33,7	142,7	22,0		1	PB	1,2
		ER 25	M8-M20	C6-391.5867-25124	124,1	102,1	42,1	44,0	42,0	162,1	28,0		1	PB	1,6
		ER 40	M16-M33	C6-391.5867-40154	153,5	131,5	52,0	62,0	62,7	191,5	39,7		1	PB	2,9
		ER 50	M20-M48	C6-391.5867-50210	210,0	136,5	78,5	86,0	78,0	248,0	56,2	*	0	-	5,9
C8		ER 20	M4-M12	C8-391.5867-20112	111,7	81,7	40,3	35,0	33,7	159,7	22,0		1	PB	2,2
		ER 25	M8-M20	C8-391.5867-25131	131,1	101,1	42,1	44,0	42,0	179,1	28,0		1	PB	2,6
		ER 40	M16-M33	C8-391.5867-40161	160,5	130,5	52,0	62,0	62,7	208,5	39,6		1	PB	3,9

* ER 50 Designation C6-391.5867-50210 features a square size 29 mm (KWW) at the bottom of the collet housing
 For ER tapping collets with square drive, see page(s) 316-317

Accessories

For size	Locking key	Socket	Spanner	Spanner 1	Torque key
ER 11	5680092-03	-	03B587511UM	-	-
ER 20	5680092-04	-	03B587520UM	-	-
ER 25	5680092-05	03ER042	03B587525	03BR042	03DYD020200
ER 40	5680092-06	03ER063	03B587540	03BR063	03DYD020200
ER 50	5680092-07	-	03B587550	-	-

Spare Parts

For size	Nut
ER 11	5533050-07
ER 20	5533051-02
ER 25	5533051-03
ER 40	5533051-05
ER 50	5533051-14

Please check availability in current price and stock-list
 For EPB 5867 sealing rings, see page(s) 320

EPB 401 – Graflex® adapters

Seco-Capto™

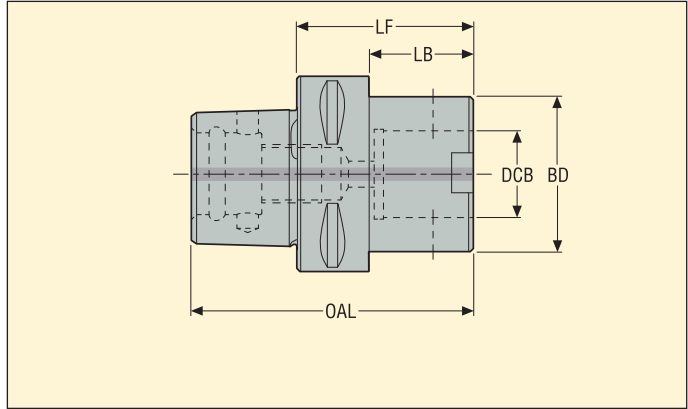

Machine side Seco-Capto™ shank	Workpiece side Graflex		Designation	Dimensions in mm				RFID hole	Balancing	
	Size	DCB mm		LF	LB	BD	OAL			
C3	G0	8	C3-391.0401-08025	25,0	7,0	16,0	44,0	0	G6.3	0,14
	G1	11	C3-391.0401-11025	25,0	7,0	20,0	44,0	0	G6.3	0,14
	G2	14	C3-391.0401-14025	25,0	7,0	25,0	44,0	0	G6.3	0,15
	G3	18	C3-391.0401-18030	30,0	0,0	32,0	49,0	0	G6.3	0,16
C4	G3	18	C4-391.0401-18035	35,0	12,0	32,0	59,0	0	G6.3	0,31
	G4	22	C4-391.0401-22035	35,0	0,0	40,0	59,0	0	G6.3	0,31
C5	G2	14	C5-391.0401-14030	30,0	7,0	25,0	60,0	1	G6.3	0,47
	G3	18	C5-391.0401-18035	35,0	12,0	32,0	65,0	1	G6.3	0,47
	G4	22	C5-391.0401-22035	35,0	12,0	40,0	65,0	1	G6.3	0,51
	G5	28	C5-391.0401-28045	45,0	22,0	50,0	75,0	1	PB	0,64
C6	G3	18	C6-391.0401-18035	35,0	10,0	32,0	73,0	1	G6.3	0,84
	G4	22	C6-391.0401-22040	40,0	15,0	40,0	78,0	1	G6.3	0,89
	G5	28	C6-391.0401-28050	50,0	25,0	50,0	88,0	1	PB	1,04
	G6	36	C6-391.0401-36055	55,0	0,0	63,0	93,0	1	PB	1,19
C8	G5	28	C8-391.0401-28050	50,0	17,0	50,0	98,0	1	PB	1,92
	G6	36	C8-391.0401-36055	55,0	22,0	63,0	103,0	1	PB	2,02
	G7	46	C8-391.0401-46065	65,0	35,0	90,0	113,0	1	PB	2,71

Accessories

For size	Locking key
G0	03H02
G1	03H02
G2	03H025
G3	03H03
G4	03H04
G5	03H05
G6	03H06
G7	03H10

Spare Parts

For size	Assembly screw
G0	90F0
G1	90F1
G2	90F2
G3	90F3
G4	90F4
G5	90F5
G6	90F6
G7	90F7

Please check availability in current price and stock-list

EPB GL – Steadyliner®, GL holders, body diameters 32, 40, 50

HSK-T/A



- With dynamic damping, ready to use
- With through coolant
- For GL turning and boring heads, see MN Turning and MN Holemaking catalogues

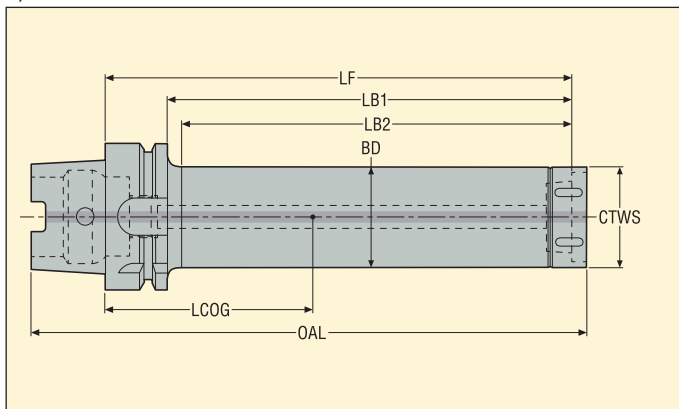

Machine side	Workpiece side	Designation	Dimensions in mm						Max. RPM*	RFID hole	Balancing	KG
			LF	LB1	LB2	BD	OAL	LCOG				
HSK-T/A 63	GL32	E9374-D32-160-GL32	160,0	118,0	112,0	32,0	197,4	58,9	10000	1	PB	1,60
	GL32	E9374-D32-224-GL32	224,0	182,0	176,0	32,0	261,4	90,2	8000	1	PB	2,00
	GL40	E9374-D40-208-GL40	208,0	166,0	160,0	40,0	246,4	92,8	8000	1	PB	2,70
	GL40	E9374-D40-288-GL40	288,0	246,0	240,0	40,0	326,4	134,4	6000	1	PB	3,50
	GL50	E9374-D50-268-GL50	268,0	226,0	224,5	50,0	307,4	131,8	6000	1	PB	4,80
	GL50	E9374-D50-368-GL50	368,0	326,0	324,5	50,0	407,4	184,8	4000	1	PB	6,40
HSK-T/A 100	GL32	E9376-D32-160-GL32	160,0	115,0	109,0	32,0	215,4	32,9	10000	1	PB	3,00
	GL32	E9376-D32-224-GL32	224,0	179,0	173,0	32,0	279,4	55,0	8000	1	PB	3,40
	GL32	E9376-D32-288-GL32	288,0	243,0	237,0	32,0	343,4	80,5	6000	1	PB	3,80
	GL40	E9376-D40-208-GL40	208,0	163,0	157,0	40,0	264,4	62,8	8000	1	PB	4,10
	GL40	E9376-D40-288-GL40	288,0	243,0	237,0	40,0	344,4	98,3	6000	1	PB	4,90
	GL40	E9376-D40-368-GL40	368,0	323,0	317,0	40,0	424,4	139,8	5000	1	PB	5,80
	GL50	E9376-D50-268-GL50	268,0	223,0	218,0	50,0	325,4	104,3	6000	1	PB	6,20
	GL50	E9376-D50-368-GL50	368,0	323,0	318,0	50,0	425,4	154,3	4000	1	PB	7,80
	GL50	E9376-D50-468-GL50	468,0	423,0	418,0	50,0	525,4	211,6	2500	1	PB	9,70

* Max. RPM only when used in rotating boring

Accessories

For nut of GL bore size	Replaceable end	Torque key
GL32	SL00-32	SL00-32.250
GL40	SL00-40	SL00-40.350
GL50	SL00-50	SL00-50.550

Spare Parts

For nut of GL bore size	Locking key
GL32	SL32
GL40	SL40
GL50	SL50

Please check availability in current price and stock-list

EPB GL – Steadyline®, GL holders, body diameters 32, 40, 50

Seco-Capto™

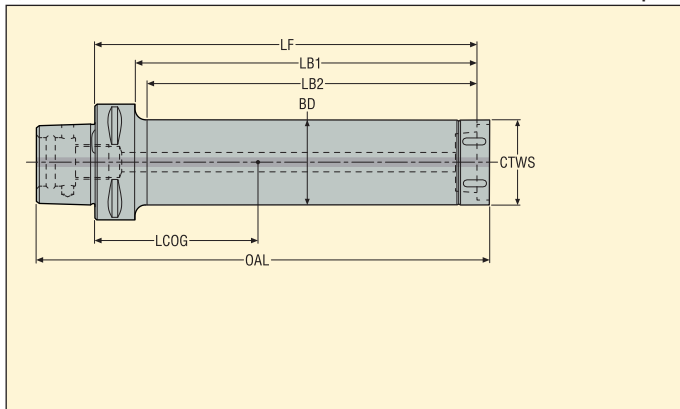

- With dynamic damping, ready to use
- With through coolant
- For GL turning and boring heads, see MN Turning and MN Holemaking catalogues

Machine side	Workpiece side	Designation	Dimensions in mm						Max. RPM*	RFID hole	Balancing	KG
			LF	LB1	LB2	BD	OAL	LCOG				
C4	GL32	C4-D32-160-GL32	160,0	137,0	134,0	32,0	189,4	74,7	10000	0	PB	1,20
	GL32	C4-D32-224-GL32	224,0	201,0	198,0	32,0	253,4	109,2	8000	0	PB	1,70
C5	GL32	C5-D32-160-GL32	160,0	137,0	133,0	32,0	195,4	65,2	10000	1	PB	1,40
	GL32	C5-D32-224-GL32	224,0	201,0	197,0	32,0	259,4	98,5	8000	1	PB	1,80
	GL32	C5-D32-288-GL32	288,0	265,0	261,0	32,0	323,4	133,6	6000	1	PB	2,20
	GL40	C5-D40-208-GL40	208,0	185,0	181,0	40,0	244,4	98,3	8000	1	PB	2,50
	GL40	C5-D40-288-GL40	288,0	265,0	261,0	40,0	324,4	140,9	6000	1	PB	3,30
	GL40	C5-D40-368-GL40	368,0	345,0	341,0	40,0	404,4	187,4	5000	1	PB	4,30
C6	GL32	C6-D32-160-GL32	160,0	135,0	129,0	32,0	203,4	52,1	10000	1	PB	1,80
	GL32	C6-D32-224-GL32	224,0	199,0	193,0	32,0	267,4	82,2	8000	1	PB	2,20
	GL32	C6-D32-288-GL32	288,0	263,0	257,0	32,0	331,4	114,9	6000	1	PB	2,60
	GL40	C6-D40-208-GL40	208,0	183,0	177,0	40,0	252,4	86,4	8000	1	PB	2,90
	GL40	C6-D40-288-GL40	288,0	263,0	257,0	40,0	332,4	127,5	6000	1	PB	3,70
	GL40	C6-D40-368-GL40	368,0	343,0	337,0	40,0	412,4	173,1	5000	1	PB	4,60
	GL50	C6-D50-268-GL50	268,0	243,0	238,0	50,0	313,4	126,6	6000	1	PB	5,00
	GL50	C6-D50-368-GL50	368,0	343,0	338,0	50,0	413,4	179,4	4000	1	PB	6,60
	GL50	C6-D50-468-GL50	468,0	443,0	438,0	50,0	513,4	238,5	2500	1	PB	8,50

* Max. RPM only when used in rotating boring

Accessories

For nut of GL bore size	Replaceable end	Torque key	For nut of GL bore size	Locking key
GL32	SL00-32	SL00-32.250	GL32	SL32
GL40	SL00-40	SL00-40.350	GL40	SL40
GL50	SL00-50	SL00-50.550	GL50	SL50

Please check availability in current price and stock-list

EPB BA – Steadyline®, BA holders, body diameters 60 and 80

Seco-Capto™



- With dynamic damping, ready to use
- To hold BA to GL adapters with GL turning heads
- With through coolant

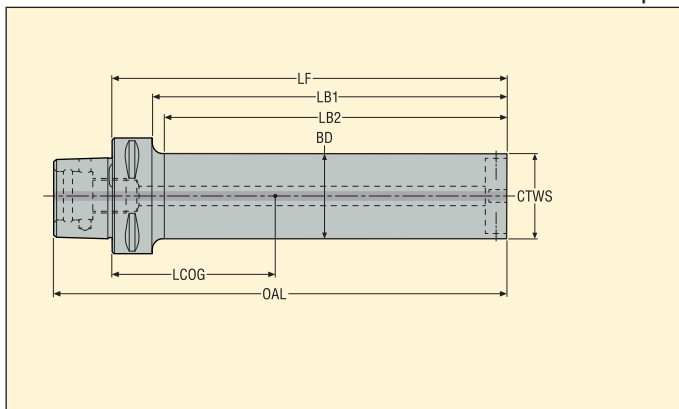

Machine side	Workpiece side	Designation	Dimensions in mm						Max. RPM*	RFID hole	Balancing	KG
			LF	BD	LB1	LB2	OAL	LCOG				
C6	BA060	C6-D60-301-BA060	301,0	60,0	276,0	273,0	339,0	151,7	4000	1	PB	7,80
	BA060	C6-D60-421-BA060	421,0	60,0	396,0	393,0	459,0	218,6	3000	1	PB	10,60
C8	BA060	C8-D60-301-BA060	301,0	60,0	268,0	263,0	349,0	137,0	4000	1	PB	8,60
	BA060	C8-D60-421-BA060	421,0	60,0	388,0	383,0	469,0	202,5	3000	1	PB	11,40
	BA060	C8-D60-541-BA060	541,0	60,0	508,0	503,0	589,0	266,8	2000	1	PB	14,00
	BA080	C8-D80-421-BA080	421,0	80,0	388,0	383,0	469,0	213,9	3000	1	PB	18,80
	BA080	C8-D80-581-BA080	581,0	80,0	548,0	543,0	629,0	300,4	2000	1	PB	25,10

* Max. RPM only when used in rotating boring (boring heads as custom made on request)

Accessories

For	Locking key
BA060	03H04
BA080	03H05

Spare Parts

For	Locking screw
BA060	90FQ4
BA080	90FQ52

Please check availability in current price and stock-list

EPB BA – Steadylin[®], BA holders, body diameters 60 and 80

Cylindrical

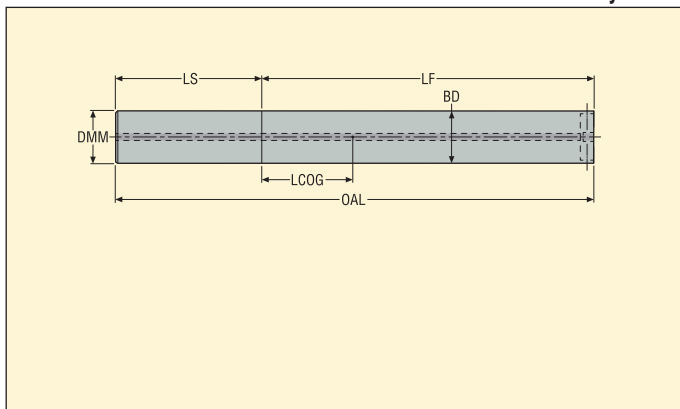

- With dynamic damping, ready to use
- To hold BA to GL adapters with GL turning heads
- With through coolant

Machine side DMM mm	Workpiece side	Designation	Dimensions in mm					RFID hole	
			LF	BD	LS	OAL	LCOG		
60	BA060	D60-301-BA060	301,0	60,0	240,0	541,0	50,1	0	12,50
	BA060	D60-541-BA060	541,0	60,0	240,0	781,0	179,1	0	18,10
80	BA080	D80-421-BA080	421,0	80,0	320,0	741,0	71,0	0	30,20
	BA080	D80-741-BA080	741,0	80,0	320,0	1061,0	241,6	0	43,40

Accessories

For	Locking key
BA060	03H04
BA080	03H05

Spare Parts

For	Locking screw
BA060	90FQ4
BA080	90FQ52

Please check availability in current price and stock-list

EPB BA – BA to GL adapters

BA

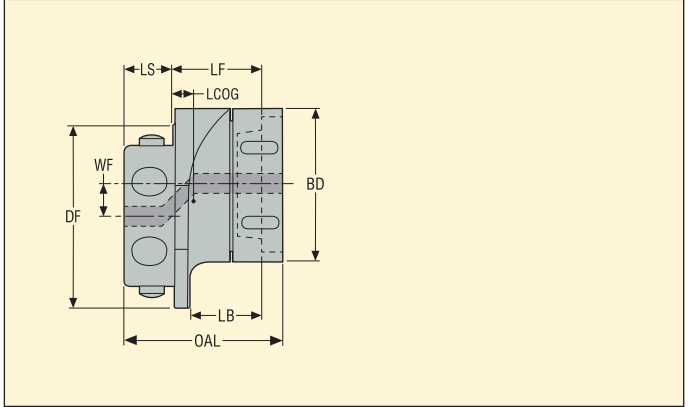

- To hold GL50 turning heads on Steadyline® BA holders
- Each adapter size available with 2 radial offset sizes WF
- With through coolant

Machine side	Workpiece side	Designation	Dimensions in mm								RFID hole	KG
			WF	LF	DF	BD	LB	LS	OAL	LCOG		
BA060	GL50	BA060-05-27-GL50	5,0	27,0	60,0	50,0	21,5	16,0	50,4	5,8	0	0,60
	GL50	BA060-10-27-GL50	10,0	27,0	60,0	50,0	21,5	16,0	50,4	5,8	0	1,00
BA080	GL50	BA080-15-27-GL50	15,0	27,0	80,0	50,0	21,5	22,0	56,4	1,4	0	0,90
	GL50	BA080-23-27-GL50	23,0	27,0	80,0	50,0	21,5	22,0	56,4	1,4	0	0,90

Accessories

Spare Parts

For	Replaceable end	Torque key	For	Locking key
GL50	SL00-50	SL00-50.550	GL50	SL50

Please check availability in current price and stock-list

HSK coolant tubes and sealing plugs

Depending on the machine requirements, HSK Form A, -B, -D, or -E holders must be equipped with a coolant tube or a sealing plug.

WARNING :

Using holders without a coolant tube or a plug fitted, when required, could cause unseen machine spindle damage.

EPB holders HSK-A and HSK-E (standard range), and HSK-B and -D (special), are delivered without coolant tube (2) or sealing plug (1).

Coolant tube (2), tube spanner (3) and sealing plug (1), when required, have to be ordered separately, see page(s) 294.

Coolant tubes, made of two parts and including two identical seals, allow a slight angular movement of $\pm 1^\circ$ (standard requirement).

They require a specific design of mounting spanner (there is no standardised design).

Sealing plugs (delivered with a seal) use standard hexagonal locking keys, not available in the catalogue.

Note: DIN 69893 Form C and -F do generally not require a coolant tube or plug. Through coolant and sealing functions are provided by the locking unit.

Pull studs

Pull studs (also called retention knobs) are the link between the drawbar of the machine and the holder. The superior material and hardening quality of EPB pull studs is important, as the pulling forces exerted on them can be up to 3000 daN on SA 50 spindles.

Precision machining of the pull studs guarantees precise positioning and safe locking of the holder in the spindle.

Most machines require a standard pull stud design (DIN, ISO, BT, CAT), but some require a specific design.

Specific pull studs are available on request, please enquire: a sketch or drawing should accompany the enquiry.

Warning: Tighten the small pull studs for SA 30 tapers with moderation, strong tightening may expand the holder's taper machine side.

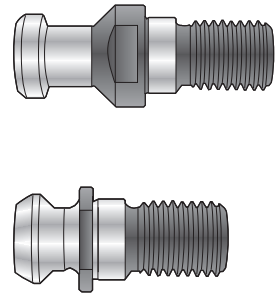
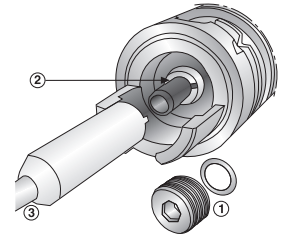

Shrinkfit extensions

Together with the Shrinkfit holders, comes a complete range of Type 5801 slim Shrinkfit extensions with cylindrical shank, tolerance h5. Extensions can be used for extending the overall length of holders, or holding small diameter tools from \varnothing 3 mm.



Reduction sleeves for hydraulic chucks

The reduction sleeves for hydraulic chucks act as split collets and allow to grip more shank types and sizes: cylindrical, Weldon, Whistle Notch $\varnothing \leq 25$ mm.

The run-out with the sleeve is maximum 5 μ m at 3 x DCB (DCB being the internal diameter of the sleeve).

Transmittable torque with a reduction sleeve is at least equivalent to chucks without a sleeve.

Note: As the grooves are not all along the sleeves, the coolant is still forced to come through the tool centre (as when using a hydraulic chuck without sleeve)..

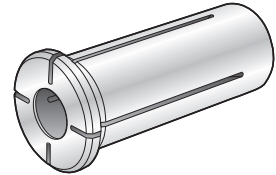

Control gauges for hydraulic chucks

Control gauges are used to check the clamping capability of the hydraulic chuck.

Hydraulic chuck control instructions summary, using a control gauge:

Insert the control gauge into the chuck.

Tighten the clamping screw until you cannot turn the control gauge.

Then it should be possible to complete a minimum of three full turns of the pressurising screw, before completely tightening (2,5 turns for \varnothing 6 mm and \varnothing 8 mm).

This will confirm that the clamping capability is adequate.

Note: Detailed control instructions are part of the operating instruction sheet delivered with the hydraulic chucks.

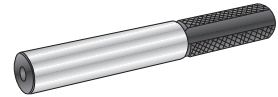

ER HP collets, type 5672 for collet chucks EPB 5672

Collet taper angle: BHTA = 16°

Coolant pressure maximum 100 bar.

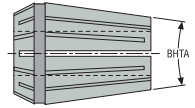

Run-out:

Maximum run-out is 3 µm (up to a maximum of 50mm) when measured at a gauge projection of 3 x DCBN-DCBX in relation to the external taper of the high precision collet chuck type 5672.

The collet designation 'ER HP' indicates that the collet type 5672 is based on the external design of ISO 15488-B (ER), but equipped with a distinguishing plastic ring in the locking groove to avoid confusing it with a classic ER collet that would not provide the run-out mentioned above.

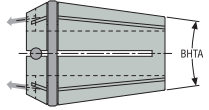

Tool shanks:

Tool shank diameter to be similar to collet's bore (no clamping capacity) and tolerance h10 max.

Range:

A selection of ER HP collets type 5672, not sealed, sealed and sealed with 4 peripheral coolant channels directed towards the cutting edge (approx. 2.5 to 3 times cutting tool diameter) is available as standard in most current diameters, as listed on page(s) 309-313.

As shown below, further diameters are available on request, please enquire.

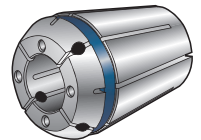
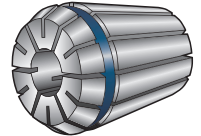

Collet size	Not sealed			Sealed			Sealed with 4 coolant supply channels		
	From Ø (mm)	To Ø (mm)	Ø steps (mm)	From Ø (mm)	To Ø (mm)	Ø steps (mm)	From Ø (mm)	To Ø (mm)	Ø steps (mm)
ER HP 11	1	7	0,5	3	6	1	–	–	–
ER HP 16*	1	10	0,5	3	10	1	3	8	1
ER HP 25	2	10	0,5	3	16	1	3	14	1
	11	16	1						
ER HP 32	2	20	1	3	20	1	3	20	1

* The collet size ER HP 16 is suitable for both chuck sizes HP 16R and HP 16.

ER collet chuck extensions, with cylindrical shanks

See also information in General guide, page(s) 49.

Extensions are an economical solution to hold smaller tool shanks in existing holders.



ER collets

Norm: ISO 15488-B

Collet taper angle: BHTA = 16°.

High flexibility: The clamping range of an ER collet is nominal to -0,5 or -1 mm.

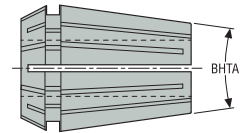

Run-out: Maximum run-out when measured at a gauge projection of 3 x DCBN-DCBX in relation to the external taper of the ER chuck type 5675 is 10 µm. When used on 5450 ER extensions the maximum run-out at 3xd is 15 µm (18 µm when using the smallest ER 08).

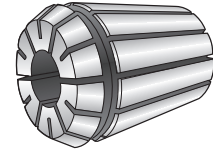

Range: A selection of ER collets in most current diameters is available as standard, as listed on page(s) 314-315.

As shown below, further diameters are available on request, please enquire.

Collet size	From \varnothing (mm)	To \varnothing (mm)	\varnothing steps (mm)	Clamping range (mm)
ER 08	1	5	0,5	-0,5
ER 11	1	7	0,5	-0,5
ER 16	1	2	0,5	-0,5
	2,5	10	0,5	-1
ER 25	1	2	0,5	-0,5
	2,5	16	0,5	-1
ER 32	2	20	0,5	-1
ER 40	3	26	0,5	-1

Sealing rings for ER sealing nuts

ER chucks are delivered as standard with drilled stop end screws for coolant through plain ended tool shanks.
In order to seal other types of shanks, sealing rings are used in conjunction with sealing nuts, see Accessories in ER collet chucks Product pages.

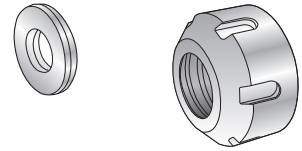

Sealing range of a ring is nominal to -0,5 mm.
Coolant pressure maximum 100 bar.

Sealing ring assembling advice: Insert sealing ring into the nut from the back, until it “clicks” into the nut’s front face. The sealing ring’s marked face should be oriented inside the nut to avoid erosion of the diameter information marking.
Release by pressure onto the sealing ring’s front face.

Range: A selection of ER sealing rings in most current diameters are available as standard, as listed on page(s) 320.
As shown below, further diameters are available on request, please enquire.

Sealing ring size	From \varnothing (mm)	To \varnothing (mm)	\varnothing steps (mm)	Sealing range (mm)
ER 16	3	10	0,5	-0,5
ER 20	3	12	0,5	-0,5
ER 25	3	16	0,5	-0,5
ER 32	3	20	0,5	-0,5
ER 40*	3	26	0,5	-0,5
ER 50*	4	25	0,5	-0,5

* Sealing rings in size ER 40 and ER 50 are only available on request, please enquire.
Note: Sealing rings and sealing nuts in sizes ER 08 and ER 11 are not available.

OZ collets

Norm: DIN 6388

Collet taper angle: $BHTA/2 = 1/10$ (approx. $2^{\circ}52'$).
High flexibility: The clamping range of an OZ collet is nominal to -0.5 mm.

Run-out: Maximum run-out when measured at a gauge projection of 3 x DCBN-DCBX in relation to the external taper of the OZ chuck type 5873 is 15 μ m.

Range: A selection of OZ 32 collets in most current diameters is available as standard, as listed on page(s) 323. As shown below, further diameters are available on request, please enquire.

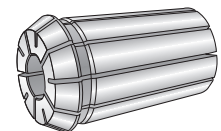
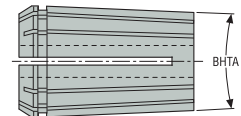

Collet size	From \varnothing (mm)	To \varnothing (mm)	\varnothing steps (mm)	Clamping range (mm)
OZ-B 32	4	32	0,5	-0,5

EPB 5867, ER tapping collets with square drive

Collet taper angle: BHTA = 16°

Specific ER collets featuring a driving square to fit the tap's square. These specific ER collets with square are required to secure the tapping process.

Dedicated clamping size on the nominal diameter.

Range: A selection of ER tapping collets in most current diameters and squares is available as standard, as listed on page(s) 316-317. As shown below, further diameters and squares are available on request, please enquire with diameter and square sizes.

Collet size	From Ø (mm)	To Ø (mm)	Clamping range
ER 11	2,5	6	0
ER 20	4,0	12	0
ER 25	4,0	16	0
ER 40	12,0	22	0
ER 50	22,0	36	0

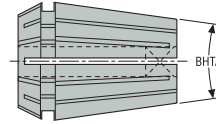

Assembly advice for ER, ER tapping collets and OZ collets

The collet must always be inserted into the nut, and the nut screwed onto the chuck before introducing the tool into the collet.

The collet is fitted inside the nut by applying slight pressure A, and released by a radial pressure B. Never lock the nut without a tool in place.

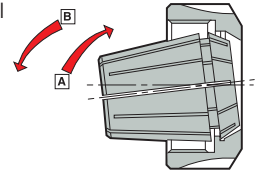

Assembly supports, Tool Boy

This indexable toolholder assembly support provides a safe and efficient tool preparation facility. Easily fixed to a workbench.

Tool Boy assembly supports are made of a base unit and a head. The common base unit accommodates all head types and sizes.

Several holder locking systems are available, depending on the type of taper: fast spring bolt for HSK/ SA40/ Seco-Capto™; screw bolt for SA50; clamping ring for VDI.

A selection of Toolboy for most current tool holder types and sizes is available as standard, as listed in the product page. Further types are available on request, please enquire.

Horizontal orientation to right or left, e.g. for tool and insert assembly.



Vertical orientation up or downwards, e.g. for boring head setting or pull stud mounting.



Torque roller spanners and classic roller spanners for EPB 5672 high precision collet chucks, EPB 5675 collet chucks, EPB 5450 collet chuck extensions, EPB 5873 OZ collet chucks, EPB 5867 Tapping chucks and ER to Combimaster holders

Roller spanners are required to tighten and release the plain cylindrical collet nuts of EPB 5672 high precision collet chucks, and are an option to the hook spanners for EPB 5675 chucks, EPB 5450 collet chuck extensions, EPB 5867 Tapping chucks and ER to Combimaster holders (see table below). Classic roller spanners and torque roller spanners are available as Accessories, to be ordered separately.

The use of a torque roller spanner is recommended for collet nut tightening: reliable application of the recommended clamping torque guarantees high transmittable torque to the tool and prevents nut or collet deformation.

For nut releasing, it is recommended to use a classic roller spanner: Torque roller spanner's key mechanism could be damaged by possible required higher untightening torque compared to the set torque for tightening.



Torque roller spanner =
Torque key + Socket



Classic roller spanner



Recommended tightening torque for the collet nut

Chuck type	Collet chuck size	Nut Ø mm	Capacity DCBN-DCBX mm	Recommended tightening torque*	Torque roller spanner*		Classic roller spanner*	Hook spanner
					Socket	Torque key		
EPB 5672	ER HP 11	16	1-7	10 Nm	03ER016	03DYD010100	03BR016	–
	ER HP 16R	24	1	10 Nm	03ER024	03DYD010100	03BR024	–
			1,5-3,5	15-20 Nm				–
			4-10	25-30 Nm				–
	ER HP 16	30	1	10 Nm	03ER030	03DYD010100	03BR030	–
			1,5-3,5	25-30 Nm				–
			4-10	50-55 Nm				–
	ER HP 25	40	2-3	25-30 Nm	03ER040	03DYD020200	03BR040	–
			3,5-6,5	35-40 Nm				–
			7-10	55-60 Nm				–
			10,5-16	80-90 Nm				–
	ER HP 32	50	2-3	30-35 Nm	03ER050	03DYD020200	03BR050	–
3,5-6,5			55-60 Nm	–				
7-15,5			110-120 Nm	–				
16-20			130-140 Nm	–				
EPB 5675	ER 16	32	0,5-10	60 Nm	03ER032	03DYD010100	03BR032	03B587516
	ER 25	42	1-16	110 Nm	03ER042	03DYD020200	03BR042	03B587525
	ER 32	50	2-20	160 Nm	03ER050	03DYD020200	03BR050	03B587532
	ER 40	63	3-26	180 Nm	03ER063	03DYD020200	03BR063	03B587540
EPB 5450	ER 08R	12	0,5-5	12 Nm	–	–	–	03B545008
	ER 11R	16	0,5-7	25 Nm	03ER016	03DYD010100	03BR016	03B545011
	ER 16R	22	0,5-10	35 Nm	03ER022	03DYD010100	03BR022	03B545016
	ER 25R	35	1-16	45 Nm	03ER035	03DYD010100	03BR035	03B545025
EPB 5873	OZ 32	72	4-32	140 Nm	–	–	–	03B587332
EPB 5867	ER 25	42	6-16	130 Nm	3ER042	03DYD020200	03BR042	03B587525
	ER 40	63	12-22	220 Nm	3ER063	03DYD020200	03BR063	03B587540
EPB 5820	ER 25 Combimaster	41,6	M8, M10, M12	60 Nm	03ER042	03DYD020200	03BR042	03B587312
	ER 32 Combimaster	49,6	M10, M12, M16	90 Nm	03ER050	03DYD020200	03BR050	03B587316
	ER 40 Combimaster	63	M12, M16, M20	120 Nm	03ER063	03DYD020200	03BR063	03B587325

* Suitable roller spanner, classic and torque types are available as Accessories, see Product pages.

Operating instructions: To ensure optimal use of the high precision collet chucks, the detailed operating instructions delivered with the holders must be respected.

HSK coolant tubes, tube spanners and sealing plugs

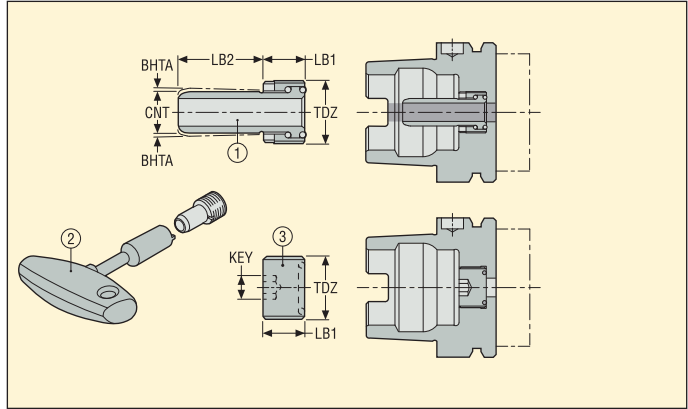

Description	For holders HSK Form A and E	Designation	TDZ	Dimensions in mm				BHTA°
				CNT	LB1	LB2	KEY	
Coolant tubes (1)	HSK-A32 & HSK-E32	20E9301	M10x1	6	6,0	20,0	–	1,0
	HSK-A40 & HSK-E40	20E9302	M12x1	8	8,0	21,5	–	1,0
	HSK-A50 & HSK-E50	20E9303	M16x1	6	10,0	23,0	–	1,0
	HSK-A63 & HSK-E63	20E9304	M18x1	8	12,0	24,5	–	1,0
	HSK-A100 & HSK-E100	20E9306	M24x1,5	6	16,0	28,0	–	1,0
Coolant tube spanners (2)	HSK-A32 & HSK-E32	03E9301	–	–	–	–	–	–
	HSK-A40 & HSK-E40	03E9302	–	–	–	–	–	–
	HSK-A50 & HSK-E50	03E9303	–	–	–	–	–	–
	HSK-A63 & HSK-E63	03E9304	–	–	–	–	–	–
	HSK-A80 & HSK-E80	03E9305	–	–	–	–	–	–
	HSK-A100 & HSK-E100	03E9306	–	–	–	–	–	–
Sealing plugs (3)	HSK-A32 & HSK-E32	02E9301	M10x1	–	6,0	–	3,0	–
	HSK-A40 & HSK-E40	02E9302	M12x1	–	8,0	–	4,0	–
	HSK-A50 & HSK-E50	02E9303	M16x1	–	10,0	–	5,0	–
	HSK-A63 & HSK-E63	02E9304	M18x1	–	12,0	–	6,0	–
	HSK-A100 & HSK-E100	02E9306	M24x1,5	–	16,0	–	10,0	–

Please check availability in current price and stock-list

Accessories, stop screws for MQL1 – DIN 69090-3



- With tapered contact surface for MQL tool according to DIN 69090-3

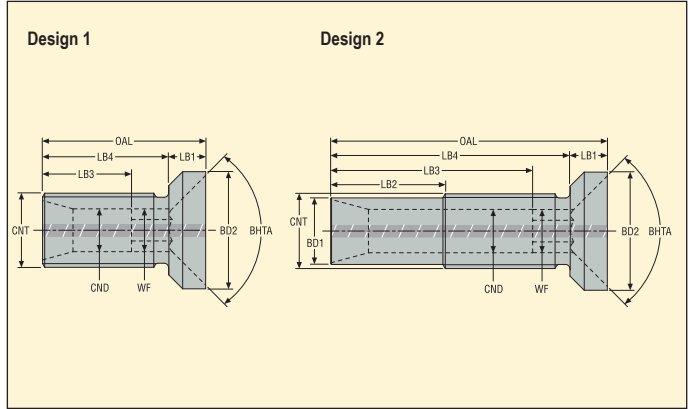

Description	CND Ø mm	Designation	Dimensions in mm								CNT	BHTA°	Design	KG	
			OAL	LB4	LB3	LB2	LB1	BD2	BD1	WF					
Short	3,0	19MQL106S	17,0	15,5	12,0	–	1,5	5,8	–	2,5	M5	90,0	1	0,1	
	3,5	19MQL108S	18,0	15,5	12,0	–	2,5	7,8	–	3,0	M6	90,0	1	0,1	
	4,7	19MQL110S	18,0	15,0	12,0	–	3,0	9,8	–	4,0	M8x1	90,0	1	0,1	
	5,8	19MQL112S	18,0	15,0	11,0	–	3,0	11,8	–	5,0	M10x1	90,0	1	0,1	
	5,8	19MQL114S	19,5	15,5	12,5	–	4,0	13,8	–	5,0	M10x1	90,0	1	0,1	
	5,8	19MQL116S	22,0	17,0	12,0	–	5,0	15,8	–	5,0	M10x1	90,0	1	0,1	
	5,8	19MQL118S	22,0	16,0	12,0	–	6,0	17,8	–	5,0	M10x1	90,0	1	0,1	
	5,8	19MQL120S	23,5	16,5	12,0	–	7,0	19,8	–	5,0	M10x1	90,0	1	0,1	
	5,8	19MQL125S	27,5	18,0	13,0	–	9,5	24,8	–	5,0	M10x1	90,0	1	0,1	
	5,8	19MQL132S	30,5	17,5	13,0	–	13,0	31,8	–	5,0	M10x1	90,0	1	0,1	
Long	3,0	19MQL106L	34,0	32,5	30,0	15,0	1,5	5,8	4,1	2,5	M5x0.8	90,0	2	0,1	
	3,5	19MQL108L	34,0	31,5	29,0	15,0	2,5	7,8	4,9	3,0	M6x1	90,0	2	0,1	
	4,7	19MQL110L	35,0	32,0	28,0	15,0	3,0	9,8	6,9	4,0	M8x1	90,0	2	0,1	
	5,8	19MQL112L	35,0	32,0	27,0	15,0	3,0	11,8	8,9	5,0	M10x1	90,0	2	0,1	
	5,8	19MQL114L	35,5	31,5	26,0	15,5	4,0	13,8	8,9	5,0	M10x1	90,0	2	0,1	
	5,8	19MQL116L	37,0	32,0	27,0	15,0	5,0	15,8	8,9	5,0	M10x1	90,0	2	0,1	
	5,8	19MQL118L	37,5	31,5	26,0	15,5	6,0	17,8	8,9	5,0	M10x1	90,0	2	0,1	
	5,8	19MQL120L	40,0	33,0	28,0	15,0	7,0	19,8	8,9	5,0	M10x1	90,0	2	0,1	
	5,8	19MQL125L	44,0	34,5	29,0	15,0	9,5	24,8	8,9	5,0	M10x1	90,0	2	0,1	
	5,8	19MQL132L	45,0	32,0	27,0	14,0	13,0	31,8	8,9	5,0	M10x1	90,0	2	0,1	

Please check availability in current price and stock-list

Accessories, coolant tubes for MQL2



- With connecting pipe

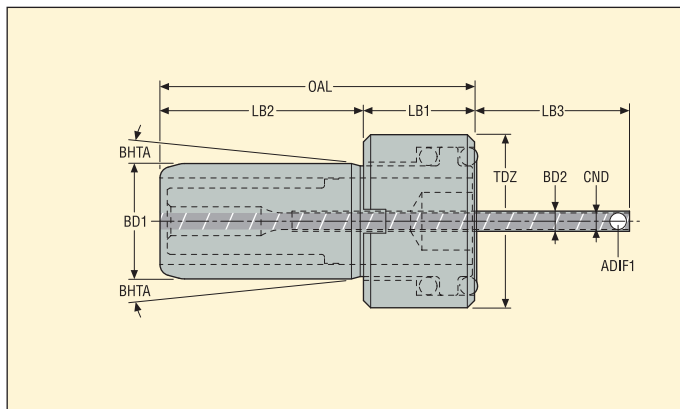

For holders	CND Ø mm	ADIF1 mm ²	Designation	Dimensions in mm							BHTA°	KG
				OAL	LB2	LB1	LB3	BD2	BD1	TDZ		
HSK-A63	1,6	2,01	20E9304M2A01	48,8	24,3	11,5	13,0	1,9	12,0	M18x1	1,0	0,1
	1,6	2,01	20E9304M2A02	50,0	24,3	11,5	14,2	1,9	12,0	M18x1	1,0	0,1
	1,6	2,01	20E9304M2A03	73,8	24,3	11,5	38,0	1,9	12,0	M18x1	1,0	0,1
	1,6	2,01	20E9304M2A04	78,8	24,3	11,5	43,0	1,9	12,0	M18x1	1,0	0,1
	1,6	2,01	20E9304M2A05	85,0	24,3	11,5	49,2	1,9	12,0	M18x1	1,0	0,1
	1,6	2,01	20E9304M2A06	90,0	24,3	11,5	54,2	1,9	12,0	M18x1	1,0	0,1
	1,6	2,01	20E9304M2A07	113,8	24,3	11,5	78,0	1,9	12,0	M18x1	1,0	0,1
	1,6	2,01	20E9304M2A08	118,8	24,3	11,5	83,0	1,9	12,0	M18x1	1,0	0,1
	1,6	2,01	20E9304M2A09	125,0	24,3	11,5	89,2	1,9	12,0	M18x1	1,0	0,1
	1,6	2,01	20E9304M2A10	130,0	24,3	11,5	94,2	1,9	12,0	M18x1	1,0	0,1
	2,3	4,15	20E9304M2B01	48,8	24,3	11,5	13,0	2,8	12,0	M18x1	1,0	0,1
	2,3	4,15	20E9304M2B02	50,0	24,3	11,5	14,2	2,8	12,0	M18x1	1,0	0,1
	2,3	4,15	20E9304M2B03	54,1	24,3	11,5	18,3	2,8	12,0	M18x1	1,0	0,1
	2,3	4,15	20E9304M2B04	60,8	24,3	11,5	25,0	2,8	12,0	M18x1	1,0	0,1
	2,3	4,15	20E9304M2B05	70,0	24,3	11,5	34,2	2,8	12,0	M18x1	1,0	0,1
	2,3	4,15	20E9304M2B06	73,8	24,3	11,5	38,0	2,8	12,0	M18x1	1,0	0,1
	2,3	4,15	20E9304M2B07	78,8	24,3	11,5	43,0	2,8	12,0	M18x1	1,0	0,1
	2,3	4,15	20E9304M2B08	85,0	24,3	11,5	49,2	2,8	12,0	M18x1	1,0	0,1
	2,3	4,15	20E9304M2B09	90,0	24,3	11,5	54,2	2,8	12,0	M18x1	1,0	0,1
	2,3	4,15	20E9304M2B10	94,1	24,3	11,5	58,3	2,8	12,0	M18x1	1,0	0,1
	2,3	4,15	20E9304M2B11	99,1	24,3	11,5	63,3	2,8	12,0	M18x1	1,0	0,1
	2,3	4,15	20E9304M2B12	110,0	24,3	11,5	74,2	2,8	12,0	M18x1	1,0	0,1
	2,3	4,15	20E9304M2B13	113,8	24,3	11,5	78,0	2,8	12,0	M18x1	1,0	0,1
	2,3	4,15	20E9304M2B14	118,8	24,3	11,5	83,0	2,8	12,0	M18x1	1,0	0,1
	2,3	4,15	20E9304M2B15	125,0	24,3	11,5	89,2	2,8	12,0	M18x1	1,0	0,1
	2,3	4,15	20E9304M2B16	130,0	24,3	11,5	94,2	2,8	12,0	M18x1	1,0	0,1
	3,4	9,08	20E9304M2C01	48,8	24,3	11,5	13,0	4,0	12,0	M18x1	1,0	0,1
	3,4	9,08	20E9304M2C02	54,1	24,3	11,5	18,3	4,0	12,0	M18x1	1,0	0,1
	3,4	9,08	20E9304M2C03	60,8	24,3	11,5	25,0	4,0	12,0	M18x1	1,0	0,1
	3,4	9,08	20E9304M2C04	70,0	24,3	11,5	34,2	4,0	12,0	M18x1	1,0	0,1
	3,4	9,08	20E9304M2C05	73,8	24,3	11,5	38,0	4,0	12,0	M18x1	1,0	0,1
	3,4	9,08	20E9304M2C06	78,8	24,3	11,5	43,0	4,0	12,0	M18x1	1,0	0,1
3,4	9,08	20E9304M2C07	94,1	24,3	11,5	58,3	4,0	12,0	M18x1	1,0	0,1	
3,4	9,08	20E9304M2C08	99,1	24,3	11,5	63,3	4,0	12,0	M18x1	1,0	0,1	
3,4	9,08	20E9304M2C09	110,0	24,3	11,5	74,2	4,0	12,0	M18x1	1,0	0,1	
3,4	9,08	20E9304M2C10	113,8	24,3	11,5	78,0	4,0	12,0	M18x1	1,0	0,1	
3,4	9,08	20E9304M2C11	118,8	24,3	11,5	83,0	4,0	12,0	M18x1	1,0	0,1	
4,6	16,62	20E9304M2D01	50,0	24,3	11,5	14,2	5,3	12,0	M18x1	1,0	0,1	
4,6	16,62	20E9304M2D02	54,1	24,3	11,5	18,3	5,3	12,0	M18x1	1,0	0,1	
4,6	16,62	20E9304M2D03	60,8	24,3	11,5	25,0	5,3	12,0	M18x1	1,0	0,1	
4,6	16,62	20E9304M2D04	70,0	24,3	11,5	34,2	5,3	12,0	M18x1	1,0	0,1	
4,6	16,62	20E9304M2D05	94,1	24,3	11,5	58,3	5,3	12,0	M18x1	1,0	0,1	

Please check availability in current price and stock-list

For HSK coolant tube spanners, see page(s) 294

Pull studs ISO/ DIN

ISO 7388-3/ DIN 69871

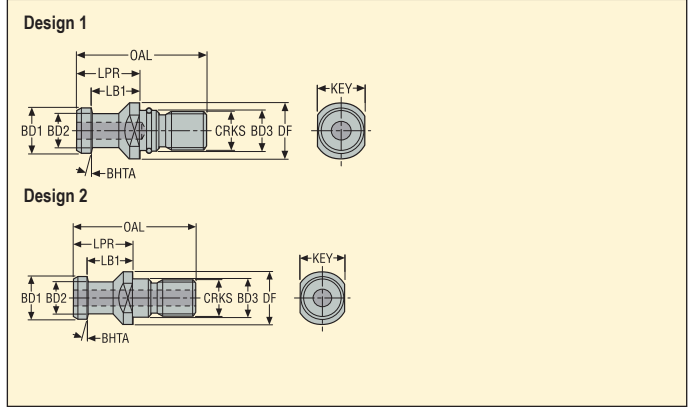

Machine side	Designation	*	CRKS	Dimensions in mm								BHTA°	Design	KG
				OAL	LPR	LB1	DF	BD3	BD2	BD1	KEY			
DIN 30	PS-I30-75-001	*	M12	44,0	24,0	19,0	17,0	13,0	9,0	13,0	14,0	15,0	1	0,10
DIN 40	PS-I40-75-001	*	M16	54,0	26,0	20,0	23,0	17,0	14,0	19,0	19,0	15,0	1	0,10
	PS-I40C-75-001		M16	54,0	26,0	20,0	23,0	17,0	14,0	19,0	19,0	15,0	2	0,10
	PS-I40C-75-002		M16	54,0	26,0	20,0	23,0	17,0	14,0	19,0	19,0	15,0	2	0,10
	PS-I40C-75-003	**	M16	54,0	29,0	23,0	23,0	17,0	14,0	19,0	19,0	15,0	2	0,10
DIN 50	PS-I50-75-001	*	M24	74,0	34,0	25,0	36,0	25,0	21,0	28,0	30,0	15,0	1	0,30
	PS-I50-75-002	*	M24	74,0	34,0	25,0	36,0	25,0	21,0	28,0	30,0	15,0	1	0,30
	PS-I50-75-003	*	M24	74,0	34,0	25,0	36,0	25,0	21,0	28,0	30,0	15,0	1	0,30
	PS-I50C-75-001		M24	74,0	34,0	25,0	36,0	25,0	21,0	28,0	30,0	15,0	2	0,30
	PS-I50C-75-002		M24	74,0	34,0	25,0	36,0	25,0	21,0	28,0	30,0	15,0	2	0,30

Please check availability in current price and stock-list

* With external sealing ring

** With internal and external sealing rings for Mori Seiki machines

Pull studs ISO/ BT JIS

ISO 7388-3/ JIS B 6339

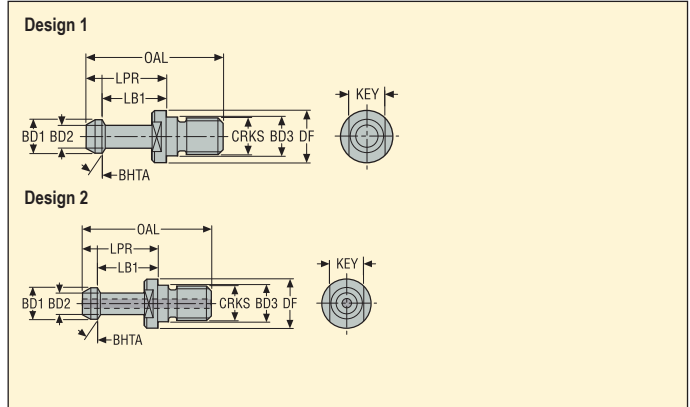

Machine side	For Taper	Designation	CRKS	Dimensions in mm							KEY	BHTA°	Design	KG	
				OAL	LPR	LB1	DF	BD3	BD2	BD1					
BT 30		PS-B30-45-001	M12	43,0	23,0	18,0	16,5	12,5	7,0	11,0	13,0	45,0	1	0,10	
		PS-B30-60-001	M12	43,0	23,0	18,0	16,5	12,5	7,0	11,0	13,0	30,0	1	0,10	
		PS-B30C-45-001	M12	43,0	23,0	18,0	16,5	12,5	7,0	11,0	13,0	45,0	2	0,10	
		PS-B30C-45-002	M12	43,0	23,0	18,0	16,5	13,0	7,0	11,0	13,0	45,0	2	0,10	
		PS-B30C-45-003	M12	43,0	23,0	18,0	16,5	12,5	8,0	11,0	13,0	45,0	2	0,10	
		PS-B30C-60-001	M12	43,0	23,0	18,0	16,5	12,5	7,0	11,0	13,0	30,0	2	0,10	
		PS-B30C-60-002	M12	43,0	23,0	18,0	16,5	12,5	7,5	11,0	13,0	30,0	2	0,10	
BT 40		PS-B40-45-001	M16	60,0	35,0	28,0	23,0	17,0	10,0	15,0	19,0	45,0	1	0,10	
		PS-B40-60-001	M16	60,0	35,0	28,0	23,0	17,0	10,0	15,0	19,0	30,0	1	0,10	
		PS-B40-90-001	M16	60,0	35,0	28,0	23,0	17,0	10,0	15,0	19,0	0,0	1	0,10	
		PS-B40C-45-001	M16	60,0	35,0	28,0	23,0	17,0	10,0	15,0	19,0	45,0	2	0,10	
		PS-B40C-60-001	M16	60,0	35,0	28,0	23,0	17,0	10,0	15,0	19,0	30,0	2	0,10	
		PS-B40C-90-001	M16	60,0	35,0	28,0	23,0	17,0	10,0	15,0	19,0	0,0	1	0,10	
BT 50		PS-B50-45-001	M24	85,0	45,0	35,0	38,0	25,0	17,0	23,0	30,0	45,0	2	0,30	
		PS-B50-60-001	M24	85,0	45,0	35,0	38,0	25,0	17,0	23,0	30,0	30,0	1	0,30	
		PS-B50-90-001	M24	85,0	45,0	35,0	38,0	25,0	17,0	23,0	30,0	0,0	1	0,30	
		PS-B50C-45-001	M24	85,0	45,0	35,0	38,0	25,0	17,0	23,0	30,0	45,0	2	0,30	
		PS-B50C-60-001	M24	85,0	45,0	35,0	38,0	25,0	17,0	23,0	30,0	30,0	2	0,30	
		PS-B50C-90-001	M24	71,0	31,0	23,0	36,0	25,0	18,0	24,0	30,0	0,0	2	0,30	
		PS-B50C-90-002	M24	85,0	45,0	35,0	38,0	25,0	17,0	23,0	30,0	0,0	2	0,30	

Please check availability in current price and stock-list

Pull studs DIN

DIN 69871

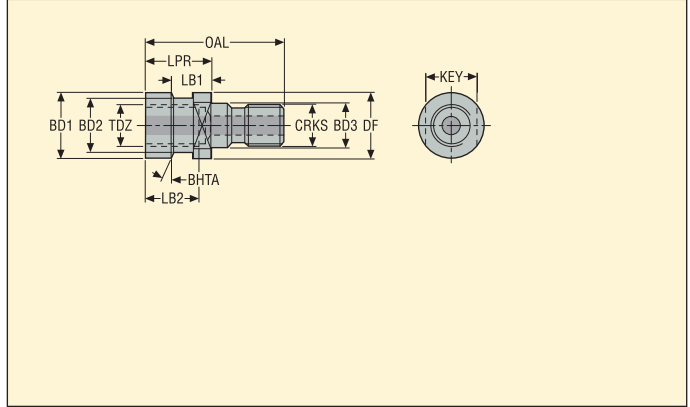

Machine side	Designation	CRKS	Dimensions in mm								KEY	TDZ	BHTA°		
			OAL	LPR	LB1	DF	BD3	BD2	BD1						
For Taper															
CAT/DIN 40, DIN 2080 compatible	PS-B40C-75-001	M16	53,1	25,1	13,7	25,3	17,0	21,1	25,3	18,0	M16	15,0	0,10		

Please check availability in current price and stock-list

EPB 5832 – Reduction sleeves for hydraulic chucks



- Run-out 5 µm maximum at 3 x ØDCB when assembled
- Nominal clamping diameter only (no clamping range)
- Tool shank tolerance h6 maximum

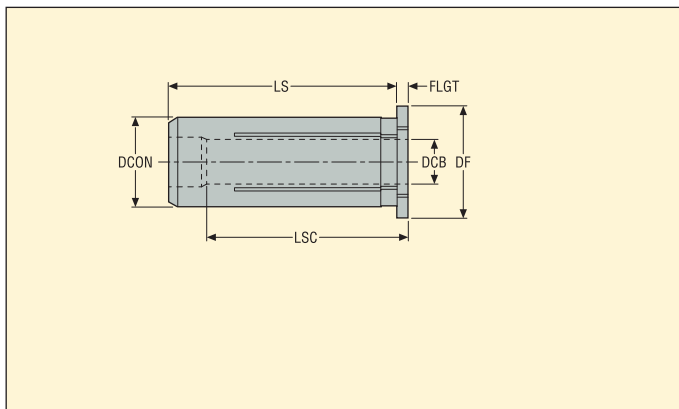

Machine side DCON mm	Workpiece side DCB mm	Designation	Dimensions in mm			
			LS	FLGT	DF	LSC
12	3	05F58321203	40,0	4,0	16,0	29,0
	4	05F58321204	40,0	4,0	16,0	29,0
	5	05F58321205	40,0	4,0	16,0	29,0
	6	05F58321206	40,0	4,0	16,0	36,0
	8	05F58321208	40,0	4,0	16,0	37,0
	10	05F58321210	40,0	4,0	16,0	40,0
20	3	05F58322003	50,0	4,0	25,0	28,0
	4	05F58322004	50,0	4,0	25,0	28,0
	5	05F58322005	50,0	4,0	25,0	28,0
	6	05F58322006	50,0	4,0	25,0	36,0
	8	05F58322008	50,0	4,0	25,0	37,0
	10	05F58322010	50,0	4,0	25,0	40,0
	12	05F58322012	50,0	4,0	25,0	45,0
	14	05F58322014	50,0	4,0	25,0	45,0
	16	05F58322016	50,0	4,0	25,0	48,0
32	6	05F58323206	60,0	4,0	36,0	36,0
	8	05F58323208	60,0	4,0	36,0	36,0
	10	05F58323210	60,0	4,0	36,0	40,0
	12	05F58323212	60,0	4,0	36,0	45,0
	14	05F58323214	60,0	4,0	36,0	46,0
	16	05F58323216	60,0	4,0	36,0	48,0
	18	05F58323218	60,0	4,0	36,0	49,0
	20	05F58323220	60,0	4,0	36,0	50,0
	25	05F58323225	60,0	4,0	36,0	56,0

Please check availability in current price and stock-list

EPB 5672 – ER HP collets, not sealed

ISO 15488-B

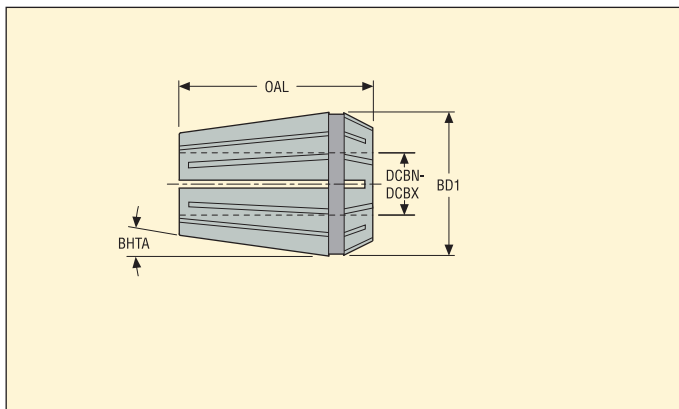

- Run-out 3 μm maximum at 3 x ∅DCBN-DCBX when assembled on a HP collet chuck, EPB 5672
- Nominal clamping diameter only (no clamping range)
- Tool shank tolerance h10 maximum

Machine side	Workpiece side	Designation	Dimensions in mm		BHTA°
			BD1	OAL	
Chuck size	Collet bore size DCBN-DCBX mm				
HP 11	1,0	56721101	11,5	18,0	8,0
	1,5	567211015	11,5	18,0	8,0
	2,0	56721102	11,5	18,0	8,0
	2,5	567211025	11,5	18,0	8,0
	3,0	56721103	11,5	18,0	8,0
	3,5	567211035	11,5	18,0	8,0
	4,0	56721104	11,5	18,0	8,0
	4,5	567211045	11,5	18,0	8,0
	5,0	56721105	11,5	18,0	8,0
	5,5	567211055	11,5	18,0	8,0
	6,0	56721106	11,5	18,0	8,0
	6,5	567211065	11,5	18,0	8,0
	7,0	56721107	11,5	18,0	8,0
HP 16	1,0	56721601	17,0	27,5	8,0
	1,5	567216015	17,0	27,5	8,0
	2,0	56721602	17,0	27,5	8,0
	2,5	567216025	17,0	27,5	8,0
	3,0	56721603	17,0	27,5	8,0
	3,5	567216035	17,0	27,5	8,0
	4,0	56721604	17,0	27,5	8,0
	4,5	567216045	17,0	27,5	8,0
	5,0	56721605	17,0	27,5	8,0
	5,5	567216055	17,0	27,5	8,0
	6,0	56721606	17,0	27,5	8,0
	6,5	567216065	17,0	27,5	8,0
	7,0	56721607	17,0	27,5	8,0
	7,5	567216075	17,0	27,5	8,0
	8,0	56721608	17,0	27,5	8,0
	8,5	567216085	17,0	27,5	8,0
	9,0	56721609	17,0	27,5	8,0
	9,5	567216095	17,0	27,5	8,0
	10,0	56721610	17,0	27,5	8,0

Please check availability in current price and stock-list

EPB 5672 – ER HP collets, not sealed

ISO 15488-B

Machine side Chuck size	Workpiece side Collet bore size DCBN-DCBX mm	Designation	Dimensions in mm		BHTA°
			BD1	OAL	
HP 25	2,0	56722502	26,0	34,0	8,0
	2,5	567225025	26,0	34,0	8,0
	3,0	56722503	26,0	34,0	8,0
	3,5	567225035	26,0	34,0	8,0
	4,0	56722504	26,0	34,0	8,0
	4,5	567225045	26,0	34,0	8,0
	5,0	56722505	26,0	34,0	8,0
	5,5	567225055	26,0	34,0	8,0
	6,0	56722506	26,0	34,0	8,0
	6,5	567225065	26,0	34,0	8,0
	7,0	56722507	26,0	34,0	8,0
	7,5	567225075	26,0	34,0	8,0
	8,0	56722508	26,0	34,0	8,0
	8,5	567225085	26,0	34,0	8,0
	9,0	56722509	26,0	34,0	8,0
	9,5	567225095	26,0	34,0	8,0
	10,0	56722510	26,0	34,0	8,0
	11,0	56722511	26,0	34,0	8,0
12,0	56722512	26,0	34,0	8,0	
13,0	56722513	26,0	34,0	8,0	
14,0	56722514	26,0	34,0	8,0	
15,0	56722515	26,0	34,0	8,0	
16,0	56722516	26,0	34,0	8,0	
HP 32	2,0	56723202	33,0	40,0	8,0
	3,0	56723203	33,0	40,0	8,0
	4,0	56723204	33,0	40,0	8,0
	5,0	56723205	33,0	40,0	8,0
	6,0	56723206	33,0	40,0	8,0
	7,0	56723207	33,0	40,0	8,0
	8,0	56723208	33,0	40,0	8,0
	9,0	56723209	33,0	40,0	8,0
	10,0	56723210	33,0	40,0	8,0
	11,0	56723211	33,0	40,0	8,0
	12,0	56723212	33,0	40,0	8,0
	13,0	56723213	33,0	40,0	8,0
	14,0	56723214	33,0	40,0	8,0
	15,0	56723215	33,0	40,0	8,0
	16,0	56723216	33,0	40,0	8,0
	17,0	56723217	33,0	40,0	8,0
	18,0	56723218	33,0	40,0	8,0
	19,0	56723219	33,0	40,0	8,0
	20,0	56723220	33,0	40,0	8,0

Please check availability in current price and stock-list

EPB 5672 – ER HP collets with coolant supply channels towards the tool

ISO 15488-B

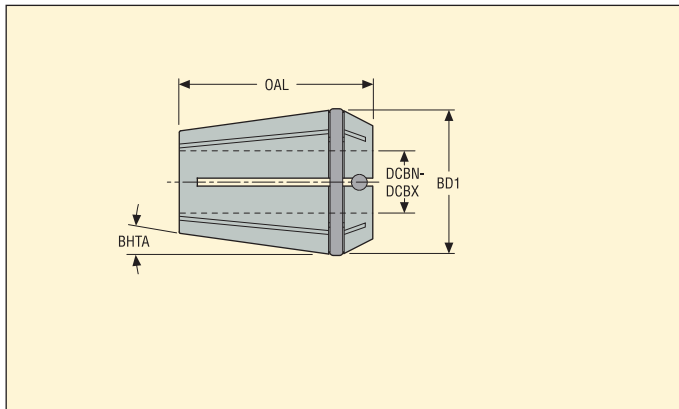

- Run-out 3 μm maximum at 3 x \varnothing DCBN-DCBX when assembled on a HP collet chuck, EPB 5672
- Nominal clamping diameter only (no clamping range)
- Tool shank tolerance h10 maximum

Machine side	Workpiece side	Designation	Dimensions in mm		BHTA°
			BD1	OAL	
Chuck size	Collet bore size DCBN-DCBX mm				
HP 16	4,0	5672S1604L	17,0	27,5	8,0
	6,0	5672S1606L	17,0	27,5	8,0
	8,0	5672S1608L	17,0	27,5	8,0
HP 25	4,0	5672S2504L	26,0	34,0	8,0
	6,0	5672S2506L	26,0	34,0	8,0
	8,0	5672S2508L	26,0	34,0	8,0
	10,0	5672S2510L	26,0	34,0	8,0
	12,0	5672S2512L	26,0	34,0	8,0
HP 32	14,0	5672S2514L	26,0	34,0	8,0
	4,0	5672S3204L	33,0	40,0	8,0
	6,0	5672S3206L	33,0	40,0	8,0
	8,0	5672S3208L	33,0	40,0	8,0
	10,0	5672S3210L	33,0	40,0	8,0
	12,0	5672S3212L	33,0	40,0	8,0
	14,0	5672S3214L	33,0	40,0	8,0
	16,0	5672S3216L	33,0	40,0	8,0
	18,0	5672S3218L	33,0	40,0	8,0
	20,0	5672S3220L	33,0	40,0	8,0

Please check availability in current price and stock-list

EPB 5880 – ER collets

ISO 15488-B



- Run-out 10 µm maximum at 3 x ØDCBN-DCBX when assembled on an ER collet chuck, EPB 5675
- Clamping range -0,5 or -1 mm

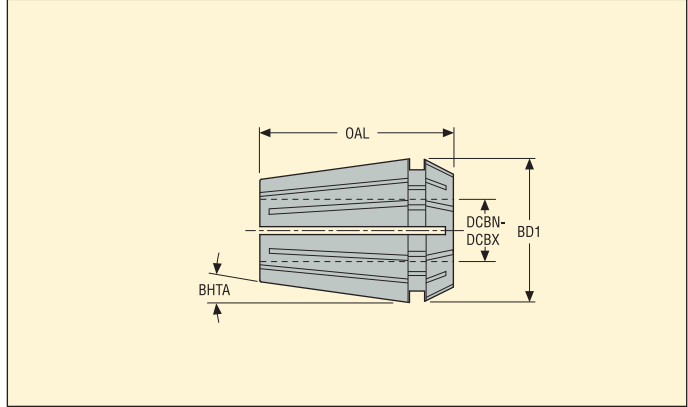

Machine side	Workpiece side	Designation	Dimensions in mm		BHTA°
			BD1	OAL	
ER 08	Collet bore size DCBN-DCBX mm				
	0,5	58800801	8,5	13,5	8,0
	1,0	588008015	8,5	13,5	8,0
	1,5	58800802	8,5	13,5	8,0
	2,0	588008025	8,5	13,5	8,0
	2,5	58800803	8,5	13,5	8,0
	3,0	588008035	8,5	13,5	8,0
	3,5	58800804	8,5	13,5	8,0
ER 11	4,0	588008045	8,5	13,5	8,0
	4,5	58800805	8,5	13,5	8,0
	0,5	58801101	11,3	18,0	8,0
	1,0	588011015	11,3	18,0	8,0
	1,5	58801102	11,3	18,0	8,0
	2,0	588011025	11,3	18,0	8,0
	2,5	58801103	11,3	18,0	8,0
	3,0	588011035	11,3	18,0	8,0
	3,5	58801104	11,3	18,0	8,0
	4,0	588011045	11,3	18,0	8,0
ER 16	4,5	58801105	11,3	18,0	8,0
	5,0	588011055	11,3	18,0	8,0
	5,5	58801106	11,3	18,0	8,0
	6,0	588011065	11,3	18,0	8,0
	6,5	58801107	11,3	18,0	8,0
	0,5	58801601	17,0	27,0	8,0
	1,5	58801602	17,0	27,0	8,0
	2,0	58801603	17,0	27,0	8,0
	3,0	58801604	17,0	27,0	8,0
	4,0	58801605	17,0	27,0	8,0
	5,0	58801606	17,0	27,0	8,0
6,0	58801607	17,0	27,0	8,0	
7,0	58801608	17,0	27,0	8,0	
8,0	58801609	17,0	27,0	8,0	
9,0	58801610	17,0	27,0	8,0	

Please check availability in current price and stock-list

EPB 5880 – ER collets

ISO 15488-B

Machine side Chuck size	Workpiece side Collet bore size DCBN-DCBX mm	Designation	Dimensions in mm		BHTA°
			BD1	OAL	
ER 25	1,5	58802502	25,8	34,0	8,0
	2,0	58802503	25,8	34,0	8,0
	3,0	58802504	25,8	34,0	8,0
	4,0	58802505	25,8	34,0	8,0
	5,0	58802506	25,8	34,0	8,0
	6,0	58802507	25,8	34,0	8,0
	7,0	58802508	25,8	34,0	8,0
	8,0	58802509	25,8	34,0	8,0
	9,0	58802510	25,8	34,0	8,0
	10,0	58802511	25,8	34,0	8,0
	11,0	58802512	25,8	34,0	8,0
	12,0	58802513	25,8	34,0	8,0
	13,0	58802514	25,8	34,0	8,0
	14,0	58802515	25,8	34,0	8,0
	15,0	58802516	25,8	34,0	8,0
ER 32	2,0	58803203	33,0	40,0	8,0
	3,0	58803204	33,0	40,0	8,0
	4,0	58803205	33,0	40,0	8,0
	5,0	58803206	33,0	40,0	8,0
	6,0	58803207	33,0	40,0	8,0
	7,0	58803208	33,0	40,0	8,0
	8,0	58803209	33,0	40,0	8,0
	9,0	58803210	33,0	40,0	8,0
	10,0	58803211	33,0	40,0	8,0
	11,0	58803212	33,0	40,0	8,0
	12,0	58803213	33,0	40,0	8,0
	13,0	58803214	33,0	40,0	8,0
	14,0	58803215	33,0	40,0	8,0
	15,0	58803216	33,0	40,0	8,0
	16,0	58803217	33,0	40,0	8,0
17,0	58803218	33,0	40,0	8,0	
18,0	58803219	33,0	40,0	8,0	
19,0	58803220	33,0	40,0	8,0	
ER 40	3,0	58804004	41,0	46,0	8,0
	4,0	58804005	41,0	46,0	8,0
	5,0	58804006	41,0	46,0	8,0
	6,0	58804007	41,0	46,0	8,0
	7,0	58804008	41,0	46,0	8,0
	8,0	58804009	41,0	46,0	8,0
	9,0	58804010	41,0	46,0	8,0
	10,0	58804011	41,0	46,0	8,0
	11,0	58804012	41,0	46,0	8,0
	12,0	58804013	41,0	46,0	8,0
	13,0	58804014	41,0	46,0	8,0
	14,0	58804015	41,0	46,0	8,0
	15,0	58804016	41,0	46,0	8,0
	16,0	58804017	41,0	46,0	8,0
	17,0	58804018	41,0	46,0	8,0
	18,0	58804019	41,0	46,0	8,0
	19,0	58804020	41,0	46,0	8,0
	20,0	58804021	41,0	46,0	8,0
	21,0	58804022	41,0	46,0	8,0
	22,0	58804023	41,0	46,0	8,0
23,0	58804024	41,0	46,0	8,0	
24,0	58804025	41,0	46,0	8,0	
25,0	58804026	41,0	46,0	8,0	

Please check availability in current price and stock-list

EPB 393.14 – ER tapping collets with square drive – Metric

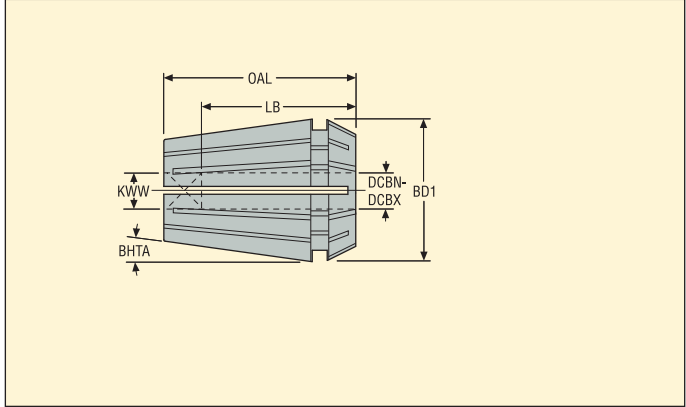

- For EPB 5867 tapping chucks

Machine side	Workpiece side	Designation	Dimensions in mm				*	BHTA°
			LB	BD1	KWW	OAL		
ER 11	2,5-2,5	393.14-11D025X021	12,0	11,3	2,1	18,0		8,0
	2,8-2,8	393.14-11D028X021	12,0	11,3	2,1	18,0		8,0
	3,5-3,5	393.14-11D035X027	14,0	11,3	2,7	18,0		8,0
	4,0-4,0	393.14-11D040X030	14,0	11,3	3,0	18,0		8,0
	4,0-4,0	393.14-11D040X0315	14,0	11,3	3,1	18,0		8,0
	4,5-4,5	393.14-11D045X034	14,0	11,3	3,4	18,0		8,0
	5,0-5,0	393.14-11D050X040	14,0	11,3	4,0	18,0		8,0
	6,0-6,0	393.14-11D060X049	14,0	11,3	4,9	18,0		8,0
ER 20	3,5-3,5	393.14-20D035X027	14,0	20,8	2,7	31,5		8,0
	4,0-4,0	393.14-20D040X0315	15,0	20,8	3,2	31,5		8,0
	4,5-4,5	393.14-20D045X034	18,0	20,8	3,4	31,5		8,0
	5,0-5,0	393.14-20D050X040	18,0	20,8	4,0	31,5		8,0
	5,5-5,5	393.14-20D055X043	18,0	20,8	4,3	31,5		8,0
	6,0-6,0	393.14-20D060X049	18,0	20,8	4,9	31,5		8,0
	6,3-6,3	393.14-20D063X050	18,0	20,8	5,0	31,5		8,0
	7,0-7,0	393.14-20D070X055	18,0	20,8	5,5	31,5		8,0
	7,1-7,1	393.14-20D071X056	18,0	20,8	5,6	31,5		8,0
	8,0-8,0	393.14-20D080X063	22,0	20,8	6,3	31,5		8,0
	9,0-9,0	393.14-20D090X071	22,0	20,8	7,1	31,5		8,0
	10,0-10,0	393.14-20D100X080	25,0	20,8	8,0	31,5		8,0
ER 25	6,0-6,0	393.14-25D060X049	18,0	25,8	4,9	34,0		8,0
	7,0-7,0	393.14-25D070X055	18,0	25,8	5,5	34,0		8,0
	8,0-8,0	393.14-25D080X063	22,0	25,8	6,3	34,0		8,0
	9,0-9,0	393.14-25D090X071	22,0	25,8	7,1	34,0		8,0
	10,0-10,0	393.14-25D100X080	25,0	25,8	8,0	34,0		8,0
	11,0-11,0	393.14-25D110X090	25,0	25,8	9,0	34,0		8,0
	11,2-11,2	393.14-25D112X090	24,8	25,8	9,0	34,0		8,0
	12,0-12,0	393.14-25D120X090	25,0	25,8	9,0	34,0		8,0
	12,5-12,5	393.14-25D125X100	24,8	25,8	10,0	34,0		8,0
	14,0-14,0	393.14-25D140X112	25,0	25,8	11,2	34,0		8,0
16,0-16,0	393.14-25D160X120	25,0	25,8	12,0	34,0		8,0	
ER 40	12,0-12,0	393.14-40D120X090	25,0	41,0	9,0	46,0		8,0
	12,5-12,5	393.14-40D125X100	24,8	41,0	10,0	46,0		8,0
	14,0-14,0	393.14-40D140X112	25,0	41,0	11,2	46,0		8,0
	16,0-16,0	393.14-40D160X125	25,0	41,0	12,5	46,0		8,0
	18,0-18,0	393.14-40D180X145	25,0	41,0	14,5	46,0		8,0
	20,0-20,0	393.14-40D200X160	28,0	41,0	16,0	46,0		8,0
	22,0-22,0	393.14-40D220X180	28,0	41,0	18,0	46,0		8,0

Please check availability in current price and stock-list

EPB 393.14 – ER tapping collets with square drive – Inch

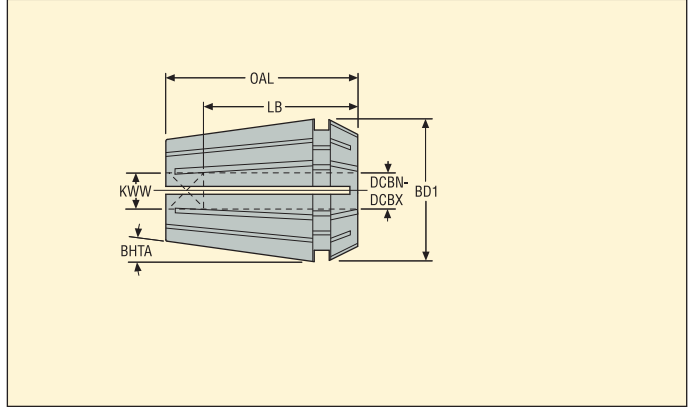

- For EPB 5867 tapping chucks

For collet chuck size	Ordering and Product No.	Designation	DCBN-DCBX inch	Dimensions in inch				*	BHTA°
				KWW	BD1	LB	OAL		
ER 11	03131636	393.14-11D025X021	0.098-0.098	0.083	0.445	0.472	0.709		8,0
	03131670	393.14-11D040X0315	0.157-0.157	0.122	0.445	0.551	0.709		8,0
	03131671	393.14-11D050X040	0.197-0.197	0.157	0.445	0.551	0.709		8,0
ER 20	03131672	393.14-20D035X027	0.138-0.138	0.106	0.819	0.551	1.240		8,0
	03131673	393.14-20D040X0315	0.157-0.157	0.124	0.819	0.591	1.240		8,0
	03131674	393.14-20D050X040	0.197-0.197	0.157	0.819	0.709	1.240		8,0
	03131675	393.14-20D055X043	0.217-0.217	0.169	0.819	0.709	1.240		8,0
	03131676	393.14-20D063X050	0.248-0.248	0.197	0.819	0.709	1.240		8,0
	03131677	393.14-20D071X056	0.280-0.280	0.220	0.819	0.709	1.240		8,0
ER 25	03131691	393.14-25D060X049	0.236-0.236	0.193	1.016	0.709	1.339		8,0
	03131692	393.14-25D070X055	0.276-0.276	0.217	1.016	0.709	1.339		8,0
	03131693	393.14-25D112X090	0.441-0.441	0.354	1.016	0.976	1.339		8,0
	03131694	393.14-25D125X100	0.492-0.492	0.394	1.016	0.976	1.339		8,0
ER 40	03131695	393.14-40D125X100	0.492-0.492	0.394	1.614	0.976	1.811		8,0
ER 50	03131696	393.14-50D220X180	0.866-0.866	0.709	1.969	1.614	2.362		8,0
	03131697	393.14-50D250X200	0.984-0.984	0.787	1.969	1.614	2.362		8,0
	03131698	393.14-50D280X220	1.102-1.102	0.866	1.969	1.614	2.362		8,0
	03131699	393.14-50D320X240	1.260-1.260	0.945	1.969	1.614	2.362		8,0
	03131700	393.14-50360	1.417-1.417	–	1.969	1.614	2.362	*	8,0

Please check availability in current price and stock-list

* ER 50 Designation 393.14-50360 is without square like a standard ER collet, For $\varnothing 1.417''$ tap shank, the square size 1.414'' is into the tapping holder

EPB A393.14 – ER tapping collets with square drive – Inch



- For EPB 5867 tapping chucks

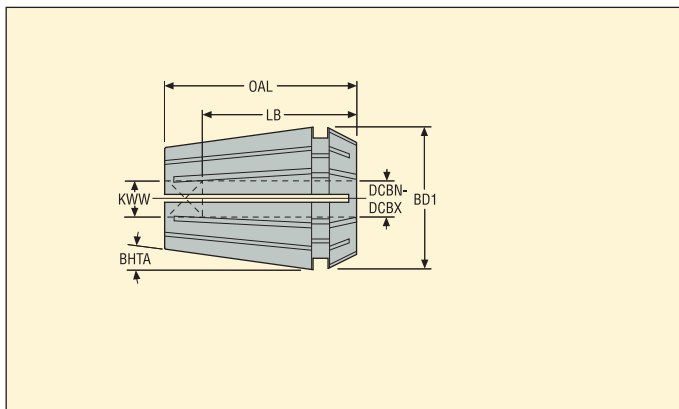

For collet chuck size	Ordering and Product No.	Designation	DCBN-DCBX inch	Dimensions in inch				BHTA°
				KWW	BD1	LB	OAL	
ER 11	03131719	A393.14-11-0-6NO	0.141-0.141	0.110	0.445	0.551	0.709	8,0
	03131720	A393.14-11-8NO	0.168-0.168	0.131	0.445	0.551	0.709	8,0
	03131721	A393.14-11-10NO	0.194-0.194	0.152	0.445	0.551	0.709	8,0
ER 20	03131722	A393.14-20-8NO	0.168-0.168	0.131	0.819	0.709	1.240	8,0
	03131723	A393.14-20-10NO	0.194-0.194	0.152	0.819	0.701	1.240	8,0
	03131724	A393.14-20-12NO	0.220-0.220	0.165	0.819	0.701	1.240	8,0
	03131725	A393.14-20-1/4	0.255-0.255	0.191	0.819	0.701	1.240	8,0
	03131726	A393.14-20-5/16	0.318-0.318	0.238	0.819	0.858	1.240	8,0
	03131727	A393.14-20-7/16	0.323-0.323	0.242	0.819	0.858	1.240	8,0
	03131728	A393.14-20-1/2	0.367-0.367	0.275	0.819	0.866	1.240	8,0
	03131733	A393.14-20-3/8	0.381-0.381	0.286	0.819	0.858	1.240	8,0
ER 25	03131738	A393.14-25-1/4	0.255-0.255	0.191	1.016	0.701	1.339	8,0
	03131739	A393.14-25-5/16	0.318-0.318	0.238	1.016	0.858	1.339	8,0
	03131741	A393.14-25-7/16	0.323-0.323	0.242	1.016	0.858	1.339	8,0
	03131742	A393.14-25-1/2	0.367-0.367	0.275	1.016	0.858	1.339	8,0
	03131743	A393.14-25-3/8	0.381-0.381	0.286	1.016	0.858	1.339	8,0
	03131744	A393.14-25-9/16	0.429-0.429	0.322	1.016	0.976	1.339	8,0
	03131745	A393.14-25-1/8P	0.437-0.437	0.328	1.016	0.976	1.339	8,0
	03131746	A393.14-25-5/8	0.480-0.480	0.360	1.016	0.976	1.339	8,0
03131747	A393.14-25-3/4	0.590-0.590	0.442	1.016	0.976	1.339	8,0	
ER 40	03131748	A393.14-40-5/8	0.480-0.480	0.360	1.614	0.976	1.811	8,0
	03131749	A393.14-40-1/2P	0.687-0.687	0.515	1.614	0.976	1.811	8,0
	03131750	A393.14-40-M18	0.542-0.542	0.406	1.614	0.976	1.811	8,0
	03131751	A393.14-40-1/8P	0.562-0.562	0.421	1.614	0.976	1.811	8,0
	03131752	A393.14-40-3/4	0.590-0.590	0.442	1.614	0.976	1.811	8,0
	03131753	A393.14-40-M20	0.652-0.652	0.489	1.614	0.976	1.811	8,0
	03131754	A393.14-40-7/8	0.697-0.697	0.523	1.614	0.976	1.811	8,0
	03131755	A393.14-40-3/8P	0.700-0.700	0.531	1.614	0.976	1.811	8,0
	03131756	A393.14-40-M24	0.760-0.760	0.570	1.614	1.094	1.811	8,0
	03131757	A393.14-40-1	0.800-0.800	0.600	1.614	1.094	1.811	8,0

Please check availability in current price and stock-list

EPB 5875 – ER sealing rings – Metric

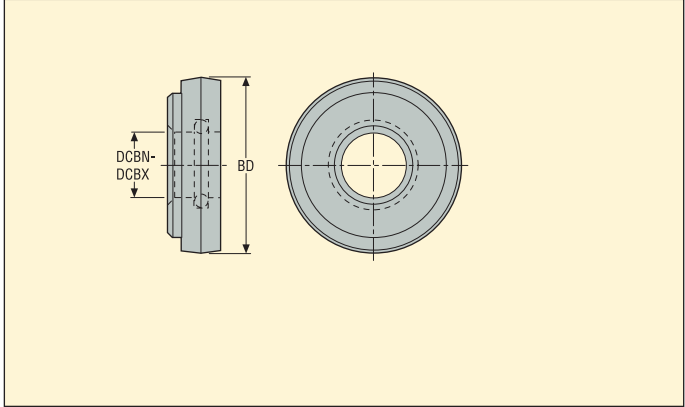

- For fitting into ER sealing nuts, for EPB 5867 Tapping chucks and EPB 5875 ER Collet chucks

For sealing nut size	Sealing capacity DCBN-DCBX mm	Designation	BD mm
ER 16	4,5-5,0	01B58751605	13,0
	5,5-6,0	01B58751606	13,0
	6,5-7,0	01B58751607	13,0
	7,5-8,0	01B58751608	13,0
	8,5-9,0	01B58751609	13,0
	9,5-10,0	01B58751610	13,0
ER 20	4,0-4,5	01B587520045	16,0
	4,5-5,0	01B58752005	16,0
	5,5-6,0	01B58752006	16,0
	6,5-7,0	01B58752007	16,0
	7,0-7,5	01B587520075	16,0
	7,5-8,0	01B58752008	16,0
	8,5-9,0	01B58752009	16,0
	9,5-10,0	01B58752010	16,0
ER 25	4,5-5,0	01B58752505	21,0
	5,5-6,0	01B58752506	21,0
	6,5-7,0	01B58752507	21,0
	7,5-8,0	01B58752508	21,0
	8,5-9,0	01B58752509	21,0
	9,5-10,0	01B58752510	21,0
	10,5-11,0	01B58752511	21,0
	11,5-12,0	01B58752512	21,0
	13,5-14,0	01B58752514	21,0
15,5-16,0	01B58752516	21,0	
ER 32	4,5-5,0	01B58753205	27,0
	5,5-6,0	01B58753206	27,0
	6,5-7,0	01B58753207	27,0
	7,5-8,0	01B58753208	27,0
	8,5-9,0	01B58753209	27,0
	9,5-10,0	01B58753210	27,0
	10,5-11,0	01B58753211	27,0
	11,5-12,0	01B58753212	27,0
	13,5-14,0	01B58753214	27,0
	15,5-16,0	01B58753216	27,0
	17,5-18,0	01B58753218	27,0
	19,5-20,0	01B58753220	27,0

Please check availability in current price and stock-list

For sealing nuts, see Accessories in ER collet chucks or Tapping chucks pages

Note: Sealing rings in size ER 40 and ER 50 are only available on request, please enquire, Not available in size ER 08 and ER 11

EPB 5875 – ER sealing rings – Inch

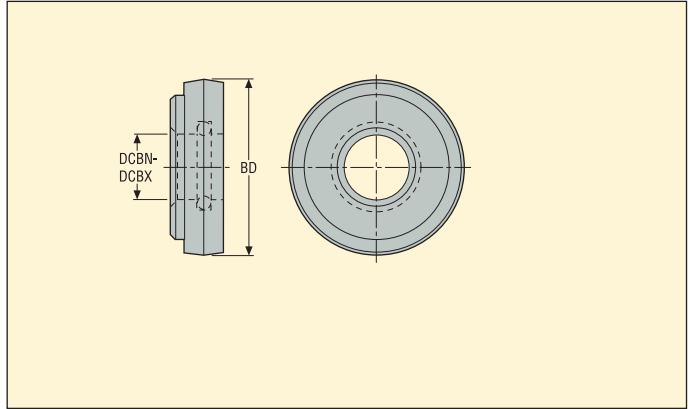

- For fitting into ER sealing nuts, for EPB 5867 Tapping chucks and EPB 5675 ER Collet chucks

For sealing nut size	Sealing capacity DCBN-DCBX inch	Ordering and Product No.	Designation	BD inch
ER 16	0.177-0.197	00029961	01B58751605	0.512
	0.217-0.236	00030314	01B58751606	0.512
	0.256-0.276	00029963	01B58751607	0.512
	0.295-0.315	00030315	01B58751608	0.512
	0.335-0.354	00029967	01B58751609	0.512
	0.374-0.394	00029968	01B58751610	0.512
ER 20	0.157-0.177	03131184	01B587520045	0.630
	0.177-0.197	03131182	01B58752005	0.630
	0.217-0.236	02427909	01B58752006	0.630
	0.256-0.276	02451138	01B58752007	0.630
	0.276-0.295	03131185	01B587520075	0.630
	0.295-0.315	02465404	01B58752008	0.630
	0.335-0.354	02700032	01B58752009	0.630
	0.374-0.394	02685743	01B58752010	0.630
ER 25	0.177-0.197	00029973	01B58752505	0.827
	0.217-0.236	00029978	01B58752506	0.827
	0.256-0.276	00029981	01B58752507	0.827
	0.295-0.315	00029982	01B58752508	0.827
	0.335-0.354	00029983	01B58752509	0.827
	0.374-0.394	00029992	01B58752510	0.827
	0.413-0.433	00029998	01B58752511	0.827
	0.453-0.472	00030000	01B58752512	0.827
	0.531-0.551	00088809	01B58752514	0.827
	0.610-0.630	00030010	01B58752516	0.827
ER 32	0.177-0.197	00030017	01B58753205	1.063
	0.217-0.236	00030316	01B58753206	1.063
	0.256-0.276	00030020	01B58753207	1.063
	0.295-0.315	00030023	01B58753208	1.063
	0.335-0.354	00030026	01B58753209	1.063
	0.374-0.394	00030028	01B58753210	1.063
	0.413-0.433	00030317	01B58753211	1.063
	0.453-0.472	00003370	01B58753212	1.063
	0.531-0.551	00057876	01B58753214	1.063
	0.610-0.630	00030319	01B58753216	1.063
	0.689-0.709	00030320	01B58753218	1.063
	0.768-0.787	00030321	01B58753220	1.063

Please check availability in current price and stock-list

For sealing nuts, see Accessories in ER collet chucks or Tapping chucks pages in MN Tooling Systems catalogue

Note: Sealing rings in size ER 40 and ER 50 are only available on request, please enquire, Not available in size ER 08 and ER 11

EPB 5820 – ER to Combimaster arbors

ER/ISO 15488

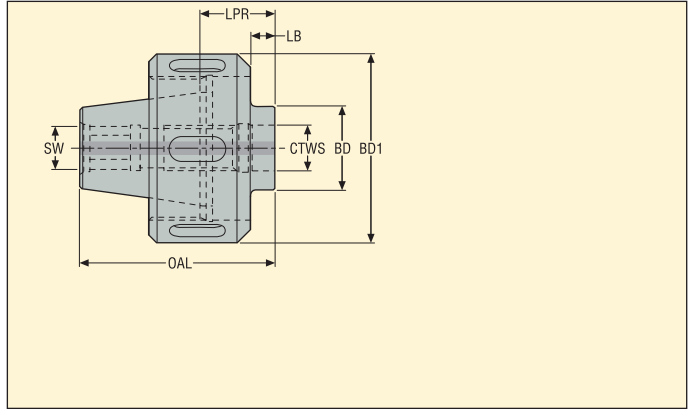

- Ready to use assembly
- To equip ER machine spindles or ER collet chucks

Machine side	Workpiece side	Designation	Dimensions in mm						RFID hole	
			LPR	LB	BD	BD1	OAL	SW		
ER 25	M8	BE025582008005	14,5	5,0	13,5	42,0	39,5	10,0	0	0,20
	M10	BE025582010005	14,5	5,0	18,5	42,0	39,5	10,0	0	0,20
	M12	BE025582012005	14,5	5,0	23,0	42,0	39,5	10,0	0	0,20
ER 32	M10	BE032582010005	15,5	5,0	18,5	50,0	46,5	10,0	0	0,40
	M12	BE032582012005	15,5	5,0	23,0	50,0	46,5	10,0	0	0,40
	M16	BE032582016005	15,5	5,0	30,0	50,0	46,5	10,0	0	0,40
ER 40	M12	BE040582012005	16,5	5,0	23,0	63,0	52,5	10,0	0	0,70
	M16	BE040582016005	16,5	5,0	30,0	63,0	52,5	10,0	0	0,70
	M20	BE040582020005	16,5	5,0	36,5	63,0	52,5	10,0	0	0,60

Accessories*

For size	Socket	Spanner 1	Spanner 2	Torque key
ER 25	03ER042	03B587312	03BR042	03DYD020200
ER 32	03ER050	03B587316	03BR050	03DYD020200
ER 40	03ER063	03B587325	03BR063	03DYD020200

Please check availability in current price and stock-list

* A torque roller spanner requires a torque key and a socket

For tightening torques, see page(s) 57, Sockets and spanners 2 use the reliable roller clamping technique

Range overview

Easyshrink® 15: compact Shrinkfit device

Induction heating and air cooling in compact design.



ZFM08IN

Packs Easyshrink® 20: Three Shrinkfit packs resulting from efficient “combinations” of previous Easyshrink® 20 modules replace these previous individual modules.

Only one part number to order a selected pack, always including heating, cooling (air and/or water) and shrink depth setting (with or without height measuring) features.



ZFM07IN10



ZFM07IN20



ZFM07IN30

Common heating features of Easyshrink® 15 and Packs Easyshrink® 20

Induction heating with shrink grip and shrink release capacity 3 to 32 mm for carbide and heavy metal, 6 to 32 mm for steel and HSS. Induction heating achieves shrink grip and shrink release in a few seconds.

'Automatic' and 'Programmable' heating mode types are available on Easyshrink® Packs N°1, 2, 3.

Note: The same heating mode types are as well available on latest Easyshrink® 15 devices with '5600 sticker', and can be achieved on earlier Easyshrink® 20 and 15 devices by upgrading them with a command cards kit '5600 compatible'.

- **6 Automatic heating modes:**

- Automatic OPTIM modes optimise the shrink grip & release heating cycles in relation to the Shrinkfit holder workpiece side type (standard, slim, reinforced) when in presence of carbide or heavy metal tool shanks: by supplying the exact required heating cycle, holders service life is maximised.

- Automatic STEEL modes ensure stronger heating cycles, for reliable shrink release of tools with HSS or steel shanks.

- How to use an Automatic mode: User selects the required automatic mode on the control panel, no need to select the diameter, then starts the heating cycle, which stops automatically.

- **2 Programmable heating modes:**

- The programmable PRG modes enable input of customised shrink grip or release heating cycles, e.g. for custom made holders and tools.

- How to use a Programmable mode: User first programs the customised cycle, in one of the 50 files of modes PRG1 and PRG2, using the control panel. Every time afterwards when the customised operation is needed, user scrolls to the programmed file on the control panel, then starts the heating cycle, which stops automatically.



Easyshrink® 15

Compact Shrinkfit device. Supports carrying Shrinkfit holders can be slid from station to station (1 heating and 2 ventilator fans air cooling stations), operator doesn't touch hot spots. Cooling made in idle time, approx. 3 minutes with finned cooling tubes or 8 minutes with cooling cones. Plate made from hard anodized aluminium allowing smooth sliding. The universal sliding support(s) can be equipped with interchangeable support rings in order to carry any kind of Shrinkfit holder. The cooling cone(s) direct the air flow towards holder's workpiece side, for faster cooling.

Delivery content:

Device is delivered with:

- 5 Standard (full set) heat focusing stoppers for 3 to 32 mm.
- 1 Universal sliding support.
- 1 Support ring for HSK63-A/C/E & HSK80-B/D/F holders.
- 1 Air cooling cone.
- A pair of gloves.
- Operating instructions.

Connections:

AC 3x400V + PE/ 16 A/ 50-60Hz. 3 meter cable is supplied.



Accessories and Spare parts for Easyshrink® 15

Only a few accessories related to the Shrinkfit holders used have to be ordered separately.

Required Easyshrink® 15 accessories:

Only one support ring for HSK63-A/C/E & HSK80-B/D/F is in the delivery content: In order to carry different Shrinkfit holders types (SA, HSK, Seco-Capto™), please order more support rings.

Optional Easyshrink® 15 accessories:

More universal sliding supports will provide idle cooling cycles: e.g. with 3 sliding supports, all 3 device's stations can be operated simultaneously.

More cooling cones may be useful when several sliding supports are in use.

When required, 5 interchangeable split heat focusing stoppers for tools with a larger head than shank, and a fitting ring, are available as Accessories.

Other optional accessories:

Several items can be added to the Easyshrink® 15 device operation: - E.g. finned cooling tubes (ZFAR02C...), or the refrigerated cooling bells water cooler (ZFM07RE1).

See Accessories and spare parts pages.



Packs Easyshrink® 20 : N°1, 2, 3

Easy to order, easy to use: Only one part number to order a selected pack, always including heating, cooling (air and/or water) and shrink depth setting (with or without height measuring) features.

Pack Easyshrink® 20 N°1, ZFM07IN10

A complete set with induction heating, 1 operating + shrink depth setting station and 2 cooling stations.



Pack Easyshrink® 20 N°2, ZFM07IN20

A complete set with induction heating, rotary plate of 3 operating + shrink depth setting + cooling stations.



Pack Easyshrink® 20 N°3, ZFM07IN30

A complete set with induction heating, rotary plate of 3 operating + shrink depth setting + cooling stations, height measuring and a refrigerated cooling bells water cooler.



Delivery content:

All Packs are delivered with:

A pair of gloves.

Five standard (full set) heat focusing stoppers for 3 to 32 mm, their storage rack and adapter.

Note: When required, 5 split heat focusing stoppers for tools with a larger head than shank are available as Accessories.

A set of 4 standard stop rods in a rack.

Operating instructions are supplied.

Additional in Packs N°1 and 2:

Two cooling cones

Connections:

All Packs:

AC 3x400V + PE/ 16 A/ 50-60Hz/ Differential breaker 30 mA. 3 meter cable is supplied. Air 3 to 6 bar/ pipe internal Ø 7 mm required (for heating system).

AC 1x230V + PE/5A/50-60Hz, cable with a DE/FR electrical plug is supplied (for air cooling).

Additional for Pack N°3 :

AC 1x230V + PE/5A/50-60Hz, cable with a DE/FR electrical plug is supplied (for refrigerated water cooler).

Packs Easyshrink® 20 : N°1, 2, 3

Accessories and Spare parts for Packs Easyshrink® 20

Only a few accessories related to the Shrinkfit holders used have to be ordered separately.

For shrink grip and shrink release operating:

Required at minimum: 1 finned support per type of Shrinkfit holder machine side taper.

For air cooling:

Required at minimum: 1 finned support or 1 support ring per type of Shrinkfit holder machine side taper. More supports and rings allow up to 3 simultaneous stations equipment.

For shrink depth setting:

Packs are delivered with a set of 4 standard stop rods with 4,2 mm workpiece side for Shrinkfit holders \varnothing 6 mm and above.

A set of 4 thin stop rods with 2,5 mm workpiece side for Shrinkfit holders \varnothing 3 to 5 mm is available as accessories.

For height measuring of Pack Easyshrink® 20 N°3:

Required at minimum: 1 tool supporting sleeve for stop rod per \varnothing of tool shank bore.

For water cooler of Pack Easyshrink® 20 N°3:

Required at minimum: 1 contact bush per size of Shrinkfit holder workpiece side.

More contact bushes allow simultaneous cooling of up to 2 holders.

See Easyshrink® Accessories and Spare parts pages.

Common and dedicated features of Packs Easyshrink® 20

Heating features

See previous 'Common heating features of Easyshrink® 15 and Packs Easyshrink® 20'



Bearing features

Operating stations hold the finned support with tool holder during the heating and cooling cycles. Pack N° 1 has one operating station with height setting.

In Packs N°2 and 3, all three stations of the rotary plate are operating, shrink depth setting and cooling stations.

Air cooling features

Ventilator fans stream air through the finned support, towards the finned cooling tube fitted onto the tool holder workpiece side or towards the cooling cone fitted onto finned supports: cooling time approx. 3 minutes with finned supports, approx. 7 minutes with cooling cones.

Pack N°1 has 2 cooling stations.

In Packs N°2 and 3, all three stations are cooling stations. The rotary plate prevents the user having any contact with hot holders: by a simple plate rotation, each station switches from the heating position to a cooling position. Each station is equipped with an LED indicator which switches on automatically when the table is rotated into a cooling position (timing approx. 3 min).

Note : the refrigerated cooling bells water cooler of Pack N°3 achieves shorter cooling times, see specific description.

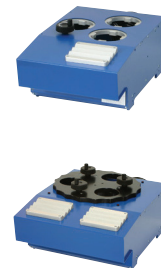

Shrink depth setting features

The fittings consist of a stop rod adjusting system, with a setting wheel (adjusting range of the fitted stop rod is 60 mm) and a set of stop rods.

Pack N° 1 has one operating station with shrink depth setting.

In Packs N°2 and 3, all three stations of the rotary plate have shrink depth setting.

Shrink depth setting instructions

A required stop rod is fitted into the shrink depth setting system, and adjusted by the setting wheel to the required Shrinkfit depth. A depth comparator or ruler is used to control the stop rod workpiece side position in reference to the holder's front face. The tool shank will bear onto the stop rod workpiece side when fitted into the holder during the shrink grip cycle. The stop rod can also be used during the shrink release cycle to push a broken tool out from the holder.

Note: Stop rod used in combination with the height measuring of Pack N°3, allows the tool's gauge length setting. Stop rod used in Packs N°1 and 2 allows only the shrink depth setting."



Dedicated height measuring features of Pack Easyshrink® 20 N°3

Pack N°3 has complementary height measuring fittings:

- A fine adjustment setting of the sliding support using a setting wheel.
- A digital rule to control the sliding support with comparator position (0,01 mm display).
- A comparator (0,01 mm) fixed onto the sliding support.

Height measuring instructions:

Precise cutting edge gauge length can be achieved when the stop rod position is set taking into account the actual tool to be shrink gripped: therefore, the above height measuring shrink depth setting fittings have to be used in combination with the stop rod adjusting systems with setting wheels and the stop rods, part of all Pack Easyshrink® 20 and described previously. The tool shank has to be located onto the stop rod front end, in order to adjust the stop rod until the cutter front end reaches the required position controlled by the digital rule and comparator. Gauge length precision $\pm 0,05$ mm is possible.



Easyshrink® refrigerated cooling bells water cooler

Note: a refrigerated cooling bells water cooler is part of Pack Easyshrink® 20 N°3. It can be added to the Easyshrink® 15 device as well as to the Packs Easyshrink® 20 N° 1 and 2.

The cooler includes a refrigeration unit and a support unit for cooling bells and contact bushes. Two aluminium bells are cooled by refrigerated water and placed over contact bushes onto the workpiece side of the holder, cooling time approx. 1 minute. There are 2 storing rests for the bells and 6 storage locations for contact bushes.

Note: If needed, one storage station can be created by the user on the body, by moving the storing rests towards the column (1 more holder placed on support rings can then be cooled by the two bells). The refrigeration unit can be stored under or to one side of the device. Operating with tap water, to be changed at minimum every 6 months. Operating instructions are supplied.

Connections:

AC 1x230V + PE/5A/50-60Hz, cable with a DE/FR electrical plug is supplied.



Accessories: Contact bushes for cooling bells

The bushes in contact with the holder workpiece side disperse heat towards the refrigerated cooling bell. Select the suitable contact bushes available as accessories to be ordered separately, see Accessories for Easyshrink®.

Accessories for Easyshrink® 15 and Packs Easyshrink® 20

Finned supports (A)

Required to provide positioning of the tool holder onto the support module (corner plate or box) during heating and cooling. Designed to let air stream towards the finned cooling tube or cooling cone. Select the suitable sizes for HSK, SA, DIN, JIS-BT, ANSI or Seco-Capto™ holders machine side tapers.

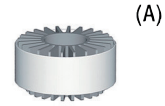

Finned cooling tubes (B)

Fins in contact with the holder's workpiece side offer a large surface area for fast heat dispersal; cooling time approx. 3 minutes. Select the suitable tube sizes available for type 5600 or 5603 Shrinkfit holders.

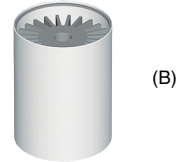

Air cooling cone (C)

The cone is a simple solution to direct the air stream towards the holder's front end (instead of using finned cooling tubes); cooling time is approx. 7 minutes. The unique cone (Part No. ZFAR03C) fits all holders. The cone fits directly onto (A), (B) or (E).

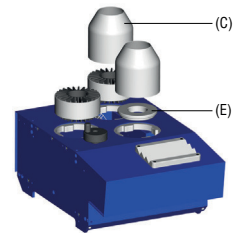

Support ring (E)

Note: Support ring are suitable for the operating and cooling station on Easyshrink® 15, for cooling stations on Easyshrink® 20 Packs, and the storage stations of the refrigerated water cooling bells unit. As an economical means of direct holder bearing, instead of using finned supports.

Sets of stop rods (G)+(H)

Stop rods are required in conjunction with the shrink depth setting fittings on Packs Easyshrink® 20. Packs Easyshrink® 20 are delivered with a set of 4 standard stop rods with 4,2 mm workpiece side for Shrinkfit holders \varnothing 6 mm and above.

A set of 4 thin stop rods with 2,5 mm workpiece side for Shrinkfit holders \varnothing 3 to 5 mm is available as accessories.

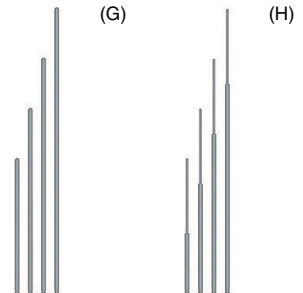

Easyshrink® 15, heating and air cooling device



	Designation	Capacity, tool shank mm		Shrinking time, approx.	Dimensions in mm			 KG
		Carbide/ Heavy metal	Steel/ HSS		Width	Depth	Height	
<ul style="list-style-type: none"> • Induction heating • 1 operating + cooling station • 1 cooling station 	ZFM08IN	∅ 3-32	∅ 6-32	10 sec.	830	410	910	45,0

Pack Easyshrink® 20, N°1



	Designation	Capacity, tool shank mm		Shrinking time, approx.	Dimensions in mm			 KG
		Carbide/ Heavy metal	Steel/ HSS		Width	Depth	Height	
<ul style="list-style-type: none"> • Induction heating • 1 operating + shrink depth setting station • 2 cooling stations 	ZFM07IN10	∅ 3-32	∅ 6-32	10 sec.	688	570	960	60,0

Pack Easyshrink® 20, N°2



	Designation	Capacity, tool shank mm		Shrinking time, approx.	Dimensions in mm			 KG
		Carbide/ Heavy metal	Steel/ HSS		Width	Depth	Height	
<ul style="list-style-type: none"> • Induction heating • Rotary plate of 3 operating + shrink depth setting + cooling stations 	ZFM07IN20	∅ 3-32	∅ 6-32	10 sec.	759	570	960	65,0

Pack Easyshrink® 20, N°3



	Designation	Capacity, tool shank mm		Shrinking time, approx.	Dimensions in mm			 KG
		Carbide/ Heavy metal	Steel/ HSS		Width	Depth	Height	
<ul style="list-style-type: none"> • Induction heating • Rotary plate of 3 operating + shrink depth setting + cooling stations • Height measuring • Refrigerated cooling bells water cooler 	ZFM07IN30	∅ 3-32	∅ 6-32	10 sec.	1084	570	960	126,0

Easyshrink® refrigerated cooling bells water cooler



	Designation	Cooling Bells Qty.	Cooling time approx.	Dimensions in mm			
				Width	Depth	Height	
<ul style="list-style-type: none"> • Refrigeration unit • Support unit 	ZFM07RE1	2	1 min	325	507	762	60,0

Contact bushes are required, see page(s) 339

This fast cooling equipment can be added onto Easyshrink® 15 or Packs Easyshrink® N°1 & N°2; it is part of Pack Easyshrink® 20 N°3

Accessories and Spare parts for Easyshrink® 15 and Easyshrink® 20 Packs, induction heating

<p>Group 1 Heat focusing stopper for tools with a larger head* (pairs of half plates ZFCE... and ring ZFCM...)</p>	<p>Group 2 Heat focusing stopper</p>	<p>Group 3 Stop rods set**</p>	<p>Group 4 Pair of protective gloves</p>
---	---	---	---

Group	Designation	For Easyshrink		For tool shank ∅ mm	BD mm	Thread fitting/ ∅ Front	For length capacity	 KG
		15	Packs 20					
1	ZFCE2521	■	■	3-6 mm	6,5	-	-	0,25
	ZFCE2522	■	■	8-14 mm	15,0	-	-	0,25
	ZFCE2523	■	■	16-18 mm	20,0	-	-	0,21
	ZFCE2524	■	■	20-25 mm	27,0	-	-	0,18
	ZFCE2525	■	■	32 mm	34,0	-	-	0,16
	ZFCM08IN000	■	■	-	-	-	-	-
2	ZFAT08C01	□	□	3-6 mm	6,5	-	-	0,29
	ZFAT08C02	□	□	8-14 mm	15,0	-	-	0,28
	ZFAT08C03	□	□	16-18 mm	20,0	-	-	0,24
	ZFAT08C04	□	□	20-25 mm	27,0	-	-	0,19
	ZFAT08C05	□	□	32 mm	34,0	-	-	0,17
3	ZFS07IN018		■	3-5 mm	-	2.5	0,0-240,0	0,1
	ZFS07IN043		□	6-32 mm	-	4.2	0,0-240,0	0,2
4	ZFAG01	□	□	-	-	-	-	0,2

■ Accessories
□ Spare parts

* Maximum tool head that can pass through the inductor is 65 mm

** A storage rack and a stop rods set for sizes 6-32 mm are part of the delivery content of the Easyshrink® 20 Packs N°1, N°2 and N°3

Accessories and Spare parts for Easyshrink® 15 and Easyshrink® 20 Packs, operating stations

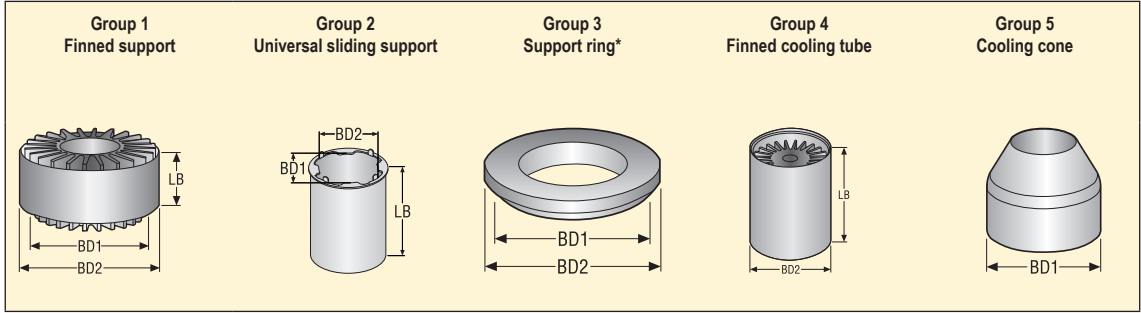

Group	Designation	For Easyshrink		For Shrinkfit holder and tool shank sizes Ø mm	Dimensions in mm			KG
		15	Packs 20		BD1	BD2	LB	
1	ZFAD05H32	■	■	HSK-A32 / HSK-C32 / HSK-E32 / HSK-B40 / HSK-D40	90,0	114,0	50,0	0,7
	ZFAD05H40	■	■	HSK-A40 / HSK-C40 / HSK-E40 / HSK-B50 / HSK-D50 / HSK-F50	90,0	114,0	50,0	0,7
	ZFAD05H50	■	■	HSK-A50 / HSK-C50 / HSK-E50 / HSK-B63 / HSK-D63 / HSK-F63	90,0	114,0	50,0	0,7
	ZFAD05H63	■	■	HSK-A63 / HSK-C63 / HSK-E63 / HSK-B80 / HSK-D80 / HSK-F80	90,0	114,0	50,0	0,7
	ZFAD05H10	■	■	HSK-A100 / HSK-C100 / HSK-B125 / HSK-D125	90,0	114,0	50,0	0,7
	ZFAD05S30	■	■	SA30	90,0	114,0	50,0	0,7
	ZFAD05S40	■	■	SA40	90,0	114,0	50,0	0,7
	ZFAD05S50	■	■	SA50	90,0	114,0	110,0	1,4
	ZFAD05C3	■	■	Seco-Capto C3	90,0	114,0	50,0	0,7
	ZFAD05C4	■	■	Seco-Capto C4	90,0	114,0	50,0	0,7
	ZFAD05C5	■	■	Seco-Capto C5	90,0	114,0	50,0	0,7
	ZFAD05C6	■	■	Seco-Capto C6	90,0	114,0	50,0	0,7
	ZFAD05C8	■	■	Seco-Capto C8	90,0	114,0	50,0	0,7
2	ZFAR08T	□	□	-	90,0	-	150,0	0,1
3	ZFAR07H32	■	■	HSK-A32 / HSK-C32 / HSK-E32 / Seco-Capto C3	90,0	99,5	-	0,2
	ZFAR07H40	■	■	HSK-A40 / HSK-C40 / HSK-E40 / HSK-B50 / HSK-D50 / HSK-F50 / Seco-Capto C4	90,0	99,5	-	0,2
	ZFAR07H50	■	■	HSK-A50 / HSK-C50 / HSK-E50 / HSK-B63 / HSK-D63 / HSK-F63	90,0	99,5	-	0,2
	ZFAR07H63	□	■	HSK-A63 / HSK-C63 / HSK-E63 / HSK-B80 / HSK-D80 / HSK-F80	90,0	99,5	-	0,2
	ZFAR07H10	■	■	HSK-A100 / HSK-C100	90,0	99,5	-	0,2
	ZFAR07C5	■	■	Seco-Capto C5	90,0	99,5	-	0,2
	ZFAR07C6	■	■	Seco-Capto C6	90,0	99,5	-	0,2
	ZFAR07C8	■	■	Seco-Capto C8	90,0	99,5	-	0,2
	ZFAR07S30	■	■	SA30	90,0	99,5	-	0,2
	ZFAR07S40	■	■	SA40	90,0	99,5	-	0,2
	ZFAR07S50	■	■	SA50	90,0	99,5	-	0,2
4	ZFAR02C306	■	■	5603 Ø6 and 8 mm	-	114,0	180,0	1,55
	ZFAR02C310	■	■	5603 Ø10 and 12 mm & 5600 Ø6 and 8 mm	-	114,0	180,0	1,55
	ZFAR02C314	■	■	5603 Ø14 and 16 mm & 5600 Ø10 and 14 mm	-	114,0	180,0	1,55
	ZFAR02C318	■	■	5603 Ø18 and 20 mm & 5600 Ø14 and 16 mm	-	114,0	180,0	1,55
	ZFAR02C325	■	■	5603 Ø25 and 32 mm & 5600 Ø18 and 20 mm	-	114,0	180,0	1,55
	ZFAR02C425	■	■	5600 Ø25 and 32	-	-	-	1,55
5	ZFAR03C	□	□	-	110,0	-	-	0,1

■ Accessories

□ Spare parts

* Support ring: For operating and cooling on Easyshrink® 15, For cooling only on Easyshrink® 20 Packs, For storage on refrigerated water cooling bells unit

Steels, ferritic and martensitic stainless steels

SMG	Description	Properties	Reference	$k_{c1.1}$	m_c
P1	Free-cutting steels	$360 < R_m < 880$	11 SMn30 $R_m = 385 \text{ N/mm}^2$	1500	0,14
P2	Low-alloy ferritic steels, $C < 0.25\% \text{wt}$ Low-alloy weldable general structural steels	$320 < R_m < 600$	S235JRG2 $R_m = 420 \text{ N/mm}^2$	1600	0,23
P3	Ferritic & ferritic/pearlitic steels, $C < 0.25\% \text{wt}$ Weldable general structural steels Case-hardening steels	$430 < R_m < 610$	16 MnCr 5 $R_m = 550 \text{ N/mm}^2$	1800	0,14
P4	Low-alloy general structural steels, $0.25\% < C < 0.67\% \text{wt}$ Low-alloy Quench & Temper steels	$520 < R_m < 1200$	C 45E $R_m = 660 \text{ N/mm}^2$	2000	0,15
P5	Structural steels, $0.25\% < C < 0.67\% \text{wt}$ Quench & Temper steels	$550 < R_m < 1200$	42 CrMo 4 $R_m = 700 \text{ N/mm}^2$	2020	0,18
P6	Low-alloy through-hardening steels, $C > 0.67\% \text{wt}$ Low-alloy spring and bearing steels	$520 < R_m < 1200$	C 100S $R_m = 600 \text{ N/mm}^2$	2100	0,17
P7	Through-hardening steels, $C > 0.67\% \text{wt}$ Spring and bearing steels	$600 < R_m < 1200$	100 Cr 6 $R_m = 650 \text{ N/mm}^2$	2160	0,17
P8	Tool steels High Speed Steels (HSS)	$600 < R_m < 1200$	X 40 CrMoV 5 1 $R_m = 700 \text{ N/mm}^2$	2400	0,20
P11	Ferritic & martensitic stainless steels	$415 < R_m < 1200$	X 20 Cr 13 $R_m = 675 \text{ N/mm}^2$	2000	0,15
P12	Maraging and precipitation-hardening stainless steels	$500 < R_m < 1200$	X 5 CrNiCuNb 16 4 $R_m = 1100 \text{ N/mm}^2$	2100	0,17

Free-cutting, austenitic and duplex stainless steels

SMG	Description	Properties	Reference	$k_{c1.1}$	m_c
M1	Free-cutting austenitic stainless steels		X 10 CrNiS 18 9	1700	0,14
M2	Low-alloy austenitic stainless steels		X 5 CrNi 18 10	1920	0,18
M3	Medium-alloy austenitic stainless steels		X 2 CrNiMo 18 14 3	2070	0,17
M4	High-alloy austenitic and duplex stainless steels		X 2 CrNiMoN 22 5 3	2230	0,16
M5	Difficult high-alloy austenitic and duplex stainless steels		X 2 CrNiMoN 25 7 4	2510	0,13

Cast irons

SMG	Description	Properties	Reference	$k_{c1.1}$	m_c
K1	Grey cast irons (GCI)		EN-GJL-250	930	0,32
K2	Compacted graphite irons (CGI)		EN-GJV-400	1000	0,35
K3	Malleable cast irons (MCI)		EN-GJMB-550-4	1050	0,37
K4	Nodular cast irons (SGI)		EN-GJS-500-7	1160	0,37
K5	Austempered ductile irons (ADI)		EN-GJS-1000-5		
K6	Austenitic lamellar cast irons		EN-GJLA-XNiCuCr15-6-2		
K7	Austenitic nodular cast irons		EN-GJSA-XNiMn23-4		

Non-ferrous metals

SMG	Description	Properties	Reference	$k_{c1.1}$	m_c
N1	Aluminium alloys, Si < 9%		AW-7075		
N2	Aluminium alloys, 9% < Si < 16%		AC-44200 Si = 12%		
N3	Aluminium alloys, Si > 16%		AlSi17Cu5		
N11	Copper alloys		CW614N	740	0,26

Superalloys and titanium

SMG	Description	Properties	Reference	$k_{c1.1}$	m_c
S1	Iron-based superalloys		Discolloy		
S2	Cobalt-based superalloys		Stellite 21		
S3	Nickel-based superalloys		Inconel 718	2530	0,21
S11	Titanium, low alloyed, (α)		Ti		
S12	Titanium, medium alloyed, ($\alpha+\beta$)		TiAl6V4	1500	0,24
S13	Titanium, high alloyed, (near β and β)		Ti10V2Fe3Al		

Hard materials

SMG	Description	Properties	Reference	$k_{c1.1}$	m_c
H3	Case-hardened steels	58 < HRC < 62	16 MnCr 5 60 HRC	2070	0,14
H5	Quenched & Tempered steels	38 < HRC < 56	42 CrMo 4 50 HRC	2320	0,18
H7	Quenched & Tempered steels Bearing steels	56 < HRC < 64	100 Cr 6 60 HRC	2480	0,17
H8	Tool steels High Speed Steels (HSS)	38 < HRC < 64	X 40 CrMoV 5 1 50 HRC	2750	0,20
H11	Martensitic stainless steels	38 < HRC < 50	X 20 Cr 13 45 HRC	2300	0,15
H12	Maraged and precipitation-hardened stainless steels	1200 < R_m < 1650	X 5 CrNiCuNb 16 4 $R_m = 1450 \text{ N/mm}^2$	2410	0,17
H21	Manganese steels	23 < HRC < 64	X 120 Mn 12 50 HRC		
H31	White cast irons	50 < HRC < 64	EN-GJN-HV600(XCr11) 55 HRC		

Other difficult materials

SMG	Description	Properties	Reference	$k_{c1.1}$	m_c
PM1	Low-alloy PM-materials		F-0008 Fe-0.7C		
PM2	Medium-alloy PM-materials		FLC-4608 Fe2Cu1.8Ni 0.5Mo0.2Mn0.8C		
PM3	High-alloy PM-materials Exhaust valve seat materials, etc.				
HF1	Hardfacing alloys Welded or plasma-deposited iron-based alloys				
HF2	Hardfacing alloys Welded or plasma-deposited cobalt- and nickel-based alloys				
CC1	Sintered tungsten carbide		G50		

Plastics and Composites

SMG	Description	Properties	Reference	$k_{c1.1}$	m_c
TS1	Thermosetting polymers		Urea formaldehyde (UF)		
TS2	Thermosetting carbon-fibre composites		T300 T700 T800 HTA-S IMA - Epoxy (M21)...		
TS3	Thermosetting glass-fibre composites		Epoxy - HX..(42..)E glass (7781...)...		
TS4	Thermosetting aramide-fibre composites		Kevlar 49		
TP1	Thermoplastic polymers		Polycarbonate (PC)		
TP2	Thermoplastic carbon-fibre composites		PPS/PEEK - T300..		
TP3	Thermoplastic glass-fibre composites		PPS/PEEK - E glass or A glass...		
TP4	Thermoplastic aramide-fibre composites				

Graphite

SMG	Description	Properties	Reference	$k_{c1.1}$	m_c
GR1	Graphite		R 8500		

SMG

SMG	EN	EN-Nr	W.-Nr	DIN	AFNOR	BS	UNI	JIS	SS	UNS
P1	11 SMn 30	1.0715	1.0715	9 SMn 28	S 250	230 M 07	CF 9 SMn 28	SUM 22	1912	G12130
	11 SMnPb 30	1.0718	1.0718	9 SMnPb 28	S 250 Pb		CF 9 SMnPb 28	SUM 22 L	1914	G12134
	10 S 20	1.0721	1.0721	10 S 20	10 F 1	210 M 15	CF 10 S 20			
			1.0722	10 SPb 20		10 PbF 2	CF 10 SPb 20			
	15 SMn 13	1.0725	1.0723	15 S 20		210 A 15		SUM 32	1922	
	35 S20	1.0726	1.0726	35 S 20	35 MF 4	212 M 36			1957	G11400
	46 S20	1.0727	1.0727	46 S 20	45 MF 4	212 M 44			1973	G11460
	11 SMn 37	1.0736	1.0736	9 SMn 36	S 300	240 M 07	CF 9 SMn 36			G12150
	11 SMn 37	1.0736	1.0736	9 SMn 36	S 300	240 M 07	CF 9 SMn 36			G12150
	P2	S235JR	1.0037	1.0037	St 37-2	E 24-2		Fe 360 B	STKM 12 C	1311
S235JRG2		1.0038	1.0116	St 37-3	E 24-3, E 24-4	4360-40 C	Fe 360 D FF		1312, 1313	
S275J2G3		1.0144	1.0144	St 44-3 N	E 28-3, E 28-4	4360-43 C	Fe 430 D FF	SM 41 C	1412, 1414	
C 10		1.0301	1.0301	C 10	34 C 10, XC 10	045 M 10	C 10	S 10 C		G10100
			1.0401	C 15	37 C 12, XC 18	080 M 15	C 15, C 16		1350	G10170
C22		1.0402	1.0402	C 22	C 20	050 A 20	C 20, C 21		1450	G10200
S355JR		1.0570	1.0570	St 52-3	E 36-3, E 36-4	4360-50 C	Fe 510 B	SM 50 YA	2172, 2132	
C 15R		1.1141	1.1141	Ck 15	XC 15, XC 18	080 M 15	C 15, C 16	S 15 C, S 15 CK	1370	G10170
			1.1158	Ck 25	XC 25	060 A 25	C 25	S 25 C		G10250
			1.2162	21 MnCr 5	20 NC 5			SCR 420 H		
P3	16 Mo 3	1.5415	1.5415	15 Mo 3	15 D 3	1501-240	16 Mo 3		2912	
			1.5423	16 Mo 5		1503-245-420	16 Mo 5	SB 450 M		G45200
	14 NiCr 14	1.5752	1.5752	14 NiCr 14	12 NC 15	655 M 13		SNC 815 (H)		G33106
			1.5919	15 CrNi 6	16 NC 6	S 107	16 CrNi 4			
	18 NiCrMo 7 6	1.6587	1.6587	18 CrNiMo 7 6	18 NCD 6	820 A 16	18 NiCrMo 7			
	16 MnCr 5	1.7131	1.7131	16 MnCr 5	16 MC 5	527 M 17	16 MnCr 5	SCR 415	2511	G51170
	16 MnCrS 5	1.7139	1.7139	16 MnCrS 5						
	20 MnCr 5	1.7147	1.7147	20 MnCr 5	20 MC 5		20 MnCr 5	SMnCr 420 (H)		G51200
	20 MnCrS 5	1.7149	1.7149	20 MnCrS 5				SMnCr 21 H		
	13 CrMo 4 5	1.7335	1.7335	13 CrMo 4 4	15 CD 3,5	1501-620 Gr. 27	14 CrMo 4 5		2216	
P4			1.7337	16 CrMo 4 4	15 CD 4,5	1501-620 Gr. 27	14 CrMo 4 5		2216	
	10 CrMo 9 10	1.7380	1.7380	10 CrMo 9 10	10 CD 9,10	1501-622 Gr. 31	12 CrMo 9 10		2218	J21890
	C35		1.0501	C 35	55 C 35	060 A 35	C 35		1550	G10350
	E 335	1.0503	1.0503	C 45	65 C 45	80 M 46	C 45	S 45 C	1650	G10430
	C40		1.0511	C 40	60 C 40	080 M 40	C 40	S 40 C		
	E 360	1.0070	1.0535	St 70-2	A 70-2		Fe 690		1655	
	C60	1.0601	1.0601	C 60	CC 55	080 A 62	C 60			G10600
			1.1157	40 Mn 4	35 M 5	150 M 36				G10390
	G 28 Mn6	1.1165	1.1165	30 Mn 5		120 M 36		SMn 1 H, SCMn 2		G13300
	C 35E	1.1181	1.1181	Ck 35	XC 38 H1	080 M 36	C 35	S 35 C	1572	G10340
C 45E	1.1191	1.1191	Ck 45	XC 42	080 M 46	C 45	S 45 C	1672	G10420	
C 60E	1.1221	1.1221	Ck 60	XC 60	080 A 62	C 60	S 58 C	1665, 1678	G10640	
P5			1.1740	C 60 W	Y3 55			SK 7		
	55 SiCr7	1.7100	1.0904	55 Si 7	55 S 7	250 A 53	55 Si 8		2085, 2090	
			1.2330	35 CrMo 4	34 CD 4	708 A 37	35 CrMo 4		2234	T51620
			1.2542	45 WCrV 7		BS 1	45 WCrV 8 KU		2710	T41901
			1.2714	56 NiCrMoV 7		BH 224-5	56 NiCrMoV7-KU	SKT 4		T61206
			1.5121	46 MnSi 4						
			1.5710	36 NiCr 6	35 NC 6	640 A 35		SNC 236		
			1.5736	36 NiCr 10	35 NC 11		35 NiCr 9	SNC 631 (H)		
	36 CrNiMo 4		1.6511	36 CrNiMo 4	40 NCD 3	816 M 40	38 NiCrMo 4 (KB)			G98400
	34 CrNiMo 6	1.6582	1.6582	34 CrNiMo 6	35 NCD 6	817 M 40	35 NiCrMo 6 (KW)	SNCM 447	2541	G43400
34 Cr 4	1.7033	1.7033	34 Cr 4	32 C 4	530 A 32	34 Cr 4 (KB)	SCR 430 (H)		G51320	
41 Cr 4	1.7035	1.7035	41 Cr 4	42 C 4	530 M 40	41 Cr 4	SCR 440 (H)		G51400	
25 CrMo 4	1.7218	1.7218	25 CrMo 4	25 CD 4 S	708 M 25	25 CrMo 4 (KB)	SCM 425	2225	G41300	
42 CrMo 4	1.7225	1.7225	42 CrMo 4	42 CD 4	708 M 40	42 CrMo 4	SCM 440 (H)	2244	G41400	
42 CrMo 4	1.7225	1.7225	42 CrMo 4	42 CD 4	708 M 40	42 CrMo 4	SCM 440 (H)	2244	G41400	
		1.7361	32 CrMo 12	30 CD 12	722 M 24	32 CrMo 12		2240		
50 CrV 4	1.8159	1.8159	50 CrV 4	50 CV 4	735 A 50	51 CrV 4	SUP 10	2230	H61500	
41 CrAlMo 7 10	1.8509	1.8509	41 CrAlMo 7	40 CAD 6.12	905 M 39	41 CrAlMo 7	SACM 645	2940	K24065	
P6	C 67S	1.1231	1.1231	Ck 67	XC 68	060 A 67	C 70		1770	G10700
	C 100S	1.1274	1.1274	Ck 101		060 A 96		SUP 4	1870	G10950
	C 105U	1.1545	1.1545	C 105 W1	Y1 105		C 100 KU		1880	
			1.1645	C 105 W2	Y1 105		C 100 KU	SK 3		
			1.1663	C 125 W	Y2 120		C 120 KU	SK 2		

SMG

U.N.E./ I.H.A.	AISI / ASTM	GOST	ČSN	Misc. Brands	Condition	Structure
	1213				Annealed	
	12 L 13				Annealed	
	1108				Annealed	
	11 L 08				Annealed	
					Annealed	
	1140	40			Annealed	
	1146				Annealed	
	1215				Annealed	
	12 L 14				Annealed	
		16D			Annealed	
	A573 Grade 58	18kp	11 378		Annealed	
	A573 Grade 70	St14kP	11 448		Annealed	
	1010	10			Annealed	
F.1110	1015	15			Annealed	
	1020, 1023	20	12 024		Annealed	
		17G1S	11 523		Annealed	
F.1511	1015	15			Annealed	
F.1120	1025	25			Annealed	
					Annealed	
	A204 Grade A		15 020		Annealed	
	4520				Annealed	
	3310, 9314	20X2H4A	16 420		Annealed	
	4320		16 220		Annealed	
					Annealed	
F.1516	5115	12KHN2	14 220		Annealed	
		18HG			Annealed	
	5120	20KH	14 221		Annealed	
	5120 H	20KH			Annealed	
	A182-F11, A182-F12	12KHM	15 121		Annealed	
	A387 Grade 12 Cl. 2				Annealed	
F.155	A182-F22	12KH8	15 313		Annealed	
F.1130	1035	35	12 040		Annealed	
F.5110	1045	45	12 050		Annealed	
	1040	40	12 041		Annealed	
F.1150	1055	55			Annealed	
	1060	60	12 061		Annealed	
	1039	40G			Annealed	
	1330	30G2			Annealed	
F.1135	1035	35			Annealed	
F.1140	1045	45	12 050		Annealed	
F.1150	1064	60			Annealed	
	1060	60			Annealed	
F.144	9255	55S2			Annealed	
F.1250	4135	35KHM			Annealed	
F.5241	S1	5KHV2S			Annealed	
	L6	5KHNV			Annealed	
	5045				Annealed	
	3135				Quenched & Tempered	
	3435				Annealed	
	9840				Quenched & Tempered	
F.1280	4340	38H2N2MA	16 343		Annealed	
	5132	35KH			Quenched & Tempered	
	5140	40H	14 140		Quenched & Tempered	
F.1251	4130	20KHM	15 130		Quenched & Tempered	
F.1252	4142, 4140	38HM	15 142		Annealed	
F.1252	4142, 4140	38HM	15 142		Quenched & Tempered	
					Quenched & Tempered	
F.143	6150	50KHFA	15 260		Quenched & Tempered	
F.1740	A355 Cl. A				Annealed	
F.5103	1070	70			Annealed	
F.5117	1095				Annealed	
F.5118	W1	U10A			Annealed	
		U10			Annealed	
	W1	U13			Annealed	

SMG

SMG	EN	EN-Nr	W.-Nr	DIN	AFNOR	BS	UNI	JIS	SS	UNS
P7	107 CrV 3	1.2210	1.2210	115 CrV 3	100 C 3		107 CrV 3 KU			T61202
			1.2510	100 MnCrV 4	90 MWCV 5	BO 1	95 MnWCr 5 KU	SKS 3	2140	T31501
	90 MnCrV 8	1.2842	1.2842	90 MnCrV 8	90 MV 8	BO 2	90 MnVCr 8 KU			T31502
	100 Cr 6	1.3505	1.3505	100 Cr 6	100 C 6	534 A 99	100 Cr 6	SUJ 2	2258	G51986
P8	X 210 Cr 12	1.2080	1.2080	X 210 Cr 12	Z 200 C 12	BD 3	X 210 Cr 13 KU	SKD 1		T30403
			1.2343	X 38 CrMoV 5 1	Z 38 CDV 5	BH 11	X 37 CrMoV 5 1 KU	SKD 6		T20811
	X 40 CrMoV 5 1	1.2344	1.2344	X 40 CrMoV 5 1	Z 40 CDV 5	BH 13	X 40 CrMo 5 1 1 KU	SKD 61	2242	T20813
	X 100 CrMoV 5	1.2363	1.2363	X 100 CrMoV 5 1	Z 100 CDV 5	BA 2	X 100 CrMoV 5 1 KU	SKD 12	2260	T30102
			1.2365	X 32 CrMoV 3 3	32 DCV 28	BH 10	30 CrMoV 12 27 KU	SKD 7		T20810
			1.2436	X 210 CrW 12			X 215 CrW 12 1 KU	SKD 2	2312	
			1.2601	X 165 CrMoV 12			X 165 CrMoV 12 KU		2310	
			1.2713	55 NiCrMoV 6	55 NCDV 7			SKT 4		T61206
	HS 6-5-2-5	1.3243	1.3243	S 6-5-2-5	Z 85 WDKCV 06-05-05-04-02		HS 6-5-2-5	SKH 55	2723	
	HS 2-10-1-8	1.3247	1.3247	S 2-10-1-8	Z 110 DKCW 09-08-04	BM 42	HS 2-9-1-8	SKH 51		T11342
HS 18-1-2-5	1.3255	1.3255	S 18-1-2-5	Z 80 WKCV 18-05-04-01	BT 4	HS 18-1-1-5	SKH 3		T12004	
HS 6-5-2	1.3343	1.3343	S 6-5-2	Z 85 WDCV 06-05-04-02	BM 2	HS 6-5-2	SKH 9, SKH 51	2722	T11302	
HS 2-9-2	1.3348	1.3348	S 2-9-2	Z 100 DCWV 09-04-02-02		HS 2-9-2	SKH 58	2782	T11307	
HS 18-0-1	1.3355	1.3355	S 18-0-1	Z 80 WCV 18-04-01	BT 1	HS 18-0-1	SKH 2		T12001	
P11	X 6 Cr 13	1.4000	1.4000	X 6 Cr 13	Z 6 C 12	403 S 17	X 6 Cr 13	SUS 403	2301	S41008
	X 12 Cr 13	1.4006	1.4006	X 10 Cr 13	Z 10 C 13	410 S 21	X 12 Cr 13	SUS 410	2302	S41000
	X 6 Cr 17	1.4016	1.4016	X 6 Cr 17	Z 8 C 17	430 S 15	X 8 Cr 17	SUS 430	2320	S43000
	X 20 Cr 13	1.4021	1.4021	X 20 Cr 13	Z 20 C 13	420 S 37	X 20 Cr 13	SUS 420 J 1	2303	S42000
	X 39 Cr 13	1.4031	1.4031	X 40 Cr 13	Z 40 C 14	420 S 45	X 40 Cr 14	SUS 420	2304	S40280
	X 70 CrMo 15	1.4109	1.4109	X 65 CrMo 14	Z 70 D 14			SUS 440 A		S44002
	X 90 CrMoV 18	1.4112	1.4112	X 90 CrMoV 18	Z 2 CND 18 05	409 S 19	X CrTi 12	SUS 440 B	2327	S44003
	X 105 CrMo 17	1.4125	1.4125	X 105 CrMo 17	Z 100 CD 17		X 105 CrMo 17	SUS 440 C		S44004
	X 3 CrNiMo 13 3	1.4313	1.4313	X 5 CrNi 13 4	Z 5 CN 13.4	425 C 11	X 6 CrNi 13 04	SCS 5	2385	S41500
X 18 CrN 28	1.4749	1.4749	X 18 CrN 28	Z 18 C 25				2322	S44600	
P12	X 6 NiCrTiMoV 25 15	1.4534	1.4534	X 3 CrNiMoAl 13 8 2						S13800
	X 4 CrNiCuNb 16 4	1.4540	1.4540	X 4 CrNiCuNb 16 4						S15500
		1.4540	1.4540	X 4 CrNiCuNb 16 4	Z 4 CNUNb 16.4 M					S15500
	X 4 CrNiCuNb 16 4	1.4540	1.4540	X 4 CrNiCuNb 16 4						S15500
	X 5 CrNiCuNb 16 4	1.4542	1.4542	X 5 CrNiCuNb 16 4				SUS 630		S17400
	X 5 CrNiCuNb 17 4	1.4548	1.4542	X 5 CrNiCuNb 17 4	Z 6 CNU 17.4			SCS 24, SUS 630		S17400
	X 7 CrNiAl 17 7	1.4564	1.4564	X 7 CrNiAl 17 7	Z 9 CAN 17.7	301 S 81	X 7 CrNiAl 17 7	SUS 631	2388	S17700
	X 2 NiCoMoTi 18 12 4	1.6356	1.6356	X 2 NiCoMoTi 18 12 4						K93160
	X 2 NiCoMoTi 18 9 5	1.6358	1.6358	X 2 NiCoMoTi 18 9 5	Z 2 NKD 19-09					K93120
	X 2 NiCoMo 18 9 5	1.6358	1.6358	X 2 NiCoMoTi 18 9 5	Z 2 NKD 19-09					K93120
X 2 NiCoMo 18 8 5	1.6359	1.6359	X 2 NiCoMo 18 8 5			S 162			K92890	
X 2 NiCoMo 18 8 5	1.6359	1.6359	X 2 NiCoMo 18 8 5			S 162			K92890	
M1	X 10 CrNiS 18 9	1.4305	1.4305	X 10 CrNiS 18 9	Z 10 CNF 18.09	303 S 31	X 10 CrNi 18 09	SUS 303	2346	S30300
	X 2 CrNi 19 11	1.4306	1.4306	X 2 CrNi 19 11	Z 2 CN 18.10	304 S 12	X 3 Cr Ni 18 11	SUS 304 L	2352	S30403
	X 5 CrNi 18 10	1.4301	1.4301	X 5 CrNi 18 10	Z 6 CN 18.09	304 S 31	X 5 CrNi 18 11	SUS 304	2333	S30400
M2	X 5 CrNiMo 17 12 2	1.4401	1.4401	X 5 CrNiMo 17 12 2	Z 3 CND 17.11.1	316 S 31	X 5 CrNiMo 17 12	SUS 316	2347	S31600
	X 6 CrNiNb 18 10	1.4550	1.4550	X 6 CrNiNb 18 10	Z 6 CNNb 18.10	347 S 31	X 6 CrNiNb 18 11	SUS 347	2338	S34700
	X 9 CrNi 18 8	1.4310	1.4310	X 12 CrNi 17 7	Z 12 CN 17.07	301 S 21	X 12 CrNi 17 07	SUS 301	(2331)	S30100
	X 12 CrNi 18 8	1.4300	1.4300	X 12 CrNi 18 8	Z 12 CN 18	302 S 25		SUS 302	2331	S30200
M3	X 2 CrNiMo 18 14 3	1.4435	1.4435	X 2 CrNiMo 18 14 3	Z 2 CND 17.13	316 S 12	X 2 CrNiMo 17 13 2	SCS 16, SUS 316 L	2353	S31603
	X 2 CrNiMoN 17 13 3	1.4429	1.4429	X 2 CrNiMoN 17 13 3	Z 2 CND 17.13 Az	316 S 62	X 2 CrNiMoN 17 13 3	SUS 316 LN	2375	S31653
	X 2 CrNiN 18 10	1.4311	1.4311	X 2 CrNiN 19 11	Z 2 CN 18. 10 Az	304 S 62	X 2 CrNiN 18 11	SUS 304 LN	2371	S30453
	X 3 CrNiMo 18 12 3	1.4466	1.4466	X 5 CrNi 18 15		317 S 16	X 5 CrNi 18 15	SUS 317	2366	S31700
	X 9 CrNiSiNCE 21 11 2	1.4835	1.4893	X 9 CrNiSiNCE 21 11 2		310 S 31			2368	S30815
	X 12 CrNi 25 21	1.4335	1.4335	X 12 CrNi 25 21	Z 12 CN 25.20	310 S 24	X 6 CrNi 26 20	SUH 310, SUS 310 S	2361	S31008
M4	X 2 CrNiMo 22 5 3	1.4462	1.4462	X 2 CrNiMoN 22 5	Z 2 CND 22.05 Az	332 S 15	X 2 CrNiMoN 22 5		2377	S31803
	X 2 CrNiMoSi 19 5	1.4424	1.4417	X 2 CrNiMoSi 19 5	Z 2 CND 18.05.03				2376	S31500
	X 2 NiCrMoCu 25 20 5	1.4539	1.4539	X 2 NiCrMoCu 25 20 5	Z 2 NCDU 25 20	904 S 13			2562	N08904
	X 3 CrNiMo 27 5 2	1.4460	1.4460	X 4 CrNiMo 27 5 2	Z 3 CND 25.7 Az		X 3 CrNiMo 27 5 2	SUS 329 J 1	2324	S32900
	X 5 CrNiCuNb 16 4	1.4980	1.4943	X 4 NiCrTi 25 15	Z 6 NCTDV 25.15	HR 51		SUH 660	2570	S66286
M5	X 1 CrNiMoN 20 18 7	1.4547	1.4529	X 1 CrNiMoN 20 18 7	Z 1 CNDU 20.18.05 Az		X 1 CrNiMoN 20 18 7		2778	S31254
	X 1 CrNiMoN 25 22 8	1.4652	1.4652	X 2 CrNiMoN 25 22 7						S32654
	X 10 NiCrAlTi 32 20	1.4876	1.4876	X 10 NiCrAlTi 32 20	Z 10 NC 32.21			NCF 800		N08800
	X 2 CrNiMoN 25 7 4	1.4410	1.4410	X 2 CrNiMoN 25 7 4	Z 3 CND 25.07 Az		X 2 CrNiMoN 25 7 4		2328	S32750

SMG

U.N.E./ I.H.A.	AISI / ASTM	GOST	ČSN	Misc. Brands	Condition	Structure
F.520L	L2	11KHF			Annealed	
F.5220	O1	9KHVG			Annealed	
	O2	9G2F			Annealed	
F.5230	52100	SHKH15	14 109		Annealed	
F.5212	D3	KH12			Annealed	
	H11	4KH5MFS			Annealed	
F.5318	H13	4KH5MF1S			Annealed	
F.5227	A2	9KH5VF			Annealed	
	H10	3KH3M3F			Annealed	
F.5213		KH12			Annealed	
		KH12MF			Annealed	
F.520.S	L6	5KHNM			Annealed	
F.5613	M35	R6M5K5			Annealed	
	M42	R2AM9K5			Annealed	
	T4	R18K5F2			Annealed	
F.5603	M2	R6M5			Annealed	
	M7				Annealed	
	T1	R18			Annealed	
	403	08KH13			Annealed	Ferritic
F.3401	410, CA-15	12KH13, 08KH13			Annealed	Martensitic
F.3113	430	12KH17			Annealed	Ferritic
F.5261	420	20KH13	17 022		Annealed	Martensitic
F.3404	420	40KH13			Annealed	Martensitic
	440 A				Annealed	Martensitic
	440 B	95KH18			Annealed	Martensitic
	440 C	95KH18			Annealed	Martensitic
	A182 F6NM			F6NM	Annealed	Martensitic
	446	15KH28			Annealed	Ferritic
	XM-13			PH 13-8 Mo	Solution annealed	Austenitic
	XM-12			15-5 PH	H1150	Martensitic
	XM-12			15-5 PH	Solution annealed	Martensitic
	XM-12			15-5 PH	H1025	Martensitic
	SAE 630			17-4 PH	H1150	Martensitic
	630			17-4 PH	Solution annealed	Martensitic
	631	09KH17N7YU1			Solution annealed	Austenitic/Ferritic
	AMS 6515			Marage 350	Solution annealed	Martensitic
	AMS 6521			Marage 300	Solution annealed	Martensitic
	AMS 6514			Marage 300, Vascomax C300	Solution annealed	Martensitic
	AMS 6512			Marage 250	Solution annealed	Martensitic
	AMS 6512			Marage 250, Vascomax C250	Solution annealed	Martensitic
F.3508	303	12KH19N9			Annealed	Austenitic
F.3504	304 L	03KH18N11			Annealed	Austenitic
F.3504	304	08KH18N10	17 240		Annealed	Austenitic
F.3534	316	08KH17H13M2T	17 346		Annealed	Austenitic
F.3524	347	08KH18N12B			Annealed	Austenitic
F.3517	301	07KH16N6			Annealed	Austenitic
	302	12KH18N9			Annealed	Austenitic
F.3533	(316 L)	03KH17N14M3	17 349		Annealed	Austenitic
	316 LN	03KH16N15M3			Annealed	Austenitic
F.3541	304 LN	03KH18N11			Annealed	Austenitic
	317	08KH17H15M3T			Annealed	Austenitic
				253 MA	Annealed	Austenitic
	310 S	12KH25N20			Annealed	Austenitic
	329 LN			SAF 2205	Annealed	Duplex
				3RE60	Annealed	Duplex
	904L				Annealed	Super austenitic
	329				Annealed	Duplex
	660			A286	Solution annealed	Austenitic
				254 SMO	Annealed	Super austenitic
				654 SMO	Annealed	Super austenitic
				Alloy 800	Annealed	Austenitic
	F 53			SAF 2507	Annealed	Super duplex

SMG

SMG	EN	EN-Nr	W.-Nr	DIN	AFNOR	BS	UNI	JIS	SS	UNS
K1	EN-GJL-150	0.6150	0.6150	GG-15	F1 15 D	Grade 150	G15	FC 150	01 15-00	F11601
	EN-GJL-200	0.6200	0.6200	GG-20	F1 20 D	Grade 220	G20	FC 200	01 20-00	F12101
	EN-GJL-250	0.6250	0.6250	GG-25	F1 25 D	Grade 260	G25	FC 250	01 25-00	F12401
	EN-GJL-350	0.6350	0.6350	GG-35	F1 35 D	Grade 350	G35	FC 350	01 35-00	F13502
K2	EN-GJL-215			GG-220 HB					02 19	
	EN-GJV-300			GJV-300						
	EN-GJV-350			GJV-350						
	EN-GJV-400			GJV-400						
	EN-GJV-450			GJV-450						
K3	EN-GJV-500			GJV-500						
	EN-GJMB-550-4	0.8155		GTS-55-04	P 540/5	P 540/5	P 55-04	PCMP55-04	08 54-00	F24130
K4	EN-GJS-350-22	0.7033	0.7033	GGG-35.3	FGS 370-17	Grade 350/22		FCD 350-22L	07 17-15	
	EN-GJS-400-15	0.7040	0.7040	GGG-40	FGS 400-12	Grade 420/12	GS 400-12	FCD 400-18L	07 17-02	F32800
	EN-GJS-400-18	0.7043	0.7043	GGG-40.3	FGS 370-17	Grade 370/17	GSO 42/17		07 17-12	F32800
	EN-GJS-500-7	0.7050	0.7050	GGG-50	FGS 500-7	Grade 500/7	GS 500-7	FCD 500-7	07 27-02	F33800
	EN-GJS-600-3	0.7060	0.7060	GGG-60	FGS 600-3	Grade 600/3	GS 600-3	FCD 600-3	07 32-03	F34100
	EN-GJS-700-2	0.7070	0.7070	GGG-70	FGS 700-2	Grade 700/2	GS 700-2	FCD 700-2	07 37-01	F34800
K5	EN-GJS-1000-5			GJS-1000-5						ADI grade 5
	EN-GJS-1200-2			GJS-1200-2						ADI grade 2
	EN-GJS-1400-1			GJS-1400-1						ADI grade 3
	EN-GJS-800-8			GJS-800-8						ADI grade 4
										ADI grade 1
K6	EN-GJLA-XNiCr 20-2	0.6660	0.6660	GGL-NiCr 20 2	FGL N120 Cr2	Grade F2			05 23-00	F41002
	EN-GJLA-XNiCr 30-3	0.6676	0.6676	GGL-NiCr 30 3	FGL N130 Cr3	Grade F3				F41004
	EN-GJLA-XNiCuCr 15-6-2	0.6655	0.6655	GGL-NiCuCr 15 6 2	FGL N115 Cu6 Cr2	Grade F1				F41000
K7	EN-GJSA-XNiMn 13-7	0.7652	0.7652	GGG-NiMn 13 7	FGS Ni13 Mn7	Grade S6			07 72-00	
	EN-GJSA-XNiCr 20-2	0.7660	0.7660	GGG-NiCr 20 2	FGS N120 Cr2	Grade S2				F43000
	EN-GJSA-XNiMn 23-4	0.7673	0.7673	GGG-NiMn 23 4	FGS Ni23 Mn4	Grade S2M				F43010
	EN-GJSA-XNiCr 30-3	0.7676	0.7676	GGG-NiCr 30 3	FGS N130 Cr3	Grade S3				F43003
N1	EN-GJSA-XNi 35	0.7683	0.7683	GGG-Ni 35	FGS Ni35					F43006
	AW-1050A	AI99.5	3.0255	AI99.5	A-5/1050A	1B		(A1050)	4007	AA1050A
	AW-2011	AlCuBiPb	3.1655	AlCuBiPb	A-U5PbBi/2011	FC1		A2011	4355	AA2011
	AW-2014	AlCuSiMn	3.1255	AlCuSiMn	A-U4SG/2014	H15			4338	AA2014
	AW-5005	AlMg1	3.3315	AlMg1	A-G0.6	N41			4106	AA5005
	AW-6060	AlMgSi0.5	3.3206	AlMgSi0.5	A-GS/6060	(H9)			4103	AA6060
	AW-6063	AlMgSi0.7	3.3210	AlMgSi0.7	A-GSUC/6061	(H10)		(A6063)	4104, 4107	AA6005
	AW-3103	AlMn1	3.0515	AlMn1		N3			4054	AA3103
	AW-3003	AlMn1Cu	3.0517	AlMn1Cu	A-M1/3003			A3003		AA3003
	AW-7020	AlZn4.5Mg1	3.4335	AlZn4.5Mg1	A-Z5G/7020	H17			4425	AA7020
	AW-7075		3.4365	AlZnMgCu1.5	A-Z5GU/7075	2L95/2L96		A7075		AA7075
	AC-42000		3.2341	G-AlSi5Mg	A-S7G	LM25	3599	AC 4C	4244	
	AC-46200	AlSi8Cu3(Si)	3.2161	G-AlSi8Cu3					4251	A13800
	MG-P-63	MgAl6Zn	3.5612	G-MgAl6Zn	G-A6-Z1	MAG-E-121				M11600
	MG-P-61	MgAl8Zn	3.5812	G-MgAl8Zn	(G-A7-Z1)					
	MN65120	MgSe3Zn2Zr1	3.5103	G-MgSe3Zn2Zr1	ZRE1	MAG6-TE				M12330
	N2	AC-43400	AlSi10Mg(Fe)	3.2381	G-AlSi10Mg	A-S10G	LM9			4253
AC-44200		AlSi12	3.2382	GD-AlSi12						
AW-6082		AlMgSi1	3.2315	AlMgSi1	A-SGM0.7/6082	H30			4212	AA6082
N3								ADC14		
	CC331G		2.0940.01	CuAl10Fe	CuAl10Fe	AB1			5710	C95200
	CC333G		2.0975.01	CuAl10Ni	CuAl10Ni5Fe5	AB2			5716	C95500
			2.0872	CuNi10Fe1Mn	CuNi10Fe1Mn	CN102			5667	C70600
				CuNi10Zn45						
			2.0790	CuNi18Zn19Pb	CuNi18Zn19Pb1					C76300
	CW352H		2.1176	CuPb10Sn	CuSn10Pb10	LB2			5640	C93700
	CC480K		2.1050.01	CuSn10	CuSn10	CT1			5443	C90700
			2.1087	CuSn10Zn					5458	C90500
	CW452K	CuSn6	2.1020	CuSn6	CuSn6	PB103		C5191	5428	C51900
	CW502L	CuZn15	2.0240	CuZn15	CuZn15	CZ102		C2300	5112	C23000
	CW706R	CuZn28Sn1	2.0470	CuZn28Sn1	CuZn29Sn1				5220	C44300
	CW508L	CuZn37	2.0321	CuZn37	CuZn37	CZ108			5150	C27200
	CW717R	CuZn38Sn1	2.0530	CuZn38Sn1						C46400
	CW614N	CuZn39Pb3	2.0401	CuZn39Pb3	CuZn39Pb3	CZ121			5170	C38500
CW612N	CuZn40Pb2	2.0402	CuZn40Pb2	CuZn39Pb2	CZ120			5168	C37800	
CW622N	CuZn44Pb2	2.0410	CuZn44Pb2		CZ104			5272	C68700	

SMG

SMG	EN	EN-Nr	W.-Nr	DIN	AFNOR	BS	UNI	JIS	SS	UNS
S1										
S2										
S3	NiMo30		2.4810							N10002
	NiMo16Cr15W		2.4819							N10276
	NiCr19Fe19Nb5Mo3		2.4668							N07718
			2.4669							N07750
	NiCr20TiAl		2.4631							N07080
	NiCr19Co18Mo4Ti3Al3									N07500
			2.4654							N07001
			3.7024							
S11										R54620
										R56320
S12	TiAl6V4		3.7164							R56400
S13				TiV10Fe2Al3						
H3	16 MnCr 5	1.7131	1.7131	16 MnCr 5	16 MC 5	527 M 17	16 MnCr 5	SCR 415	2511	G51170
H5	C 67S	1.1231	1.1231	Ck 67	XC 68	060 A 67	C 70		1770	G10700
	C 75S	1.1248	1.1248	Ck 75	XC 75	060 A 78	C 75		1774, 1778	G10780
	C 100S	1.1274	1.1274	Ck 101		060 A 96		SUP 4	1870	G10950
	C 105U	1.1545	1.1545	C 105 W1	Y1 105		C 100 KU		1880	
			1.2550	60 WCrV 7	55 WC 20		55 WCrV 8 KU			
	55 Cr 3	1.7176	1.7176	55 Cr 3	55 C 3	527 A 60	55 Cr 3	SUP 9 (A)	2253	G51550
42 CrMo 4	1.7225	1.7225	42 CrMo 4	42 CD 4	708 M 40	42 CrMo 4	SCM 440 (H)	2244	G41400	
107 CrV 3	1.2210	1.2210	115 CrV 3	100 C 3		107 CrV 3 KU			T61202	
H7			1.2510	100 MnCrW 4	90 MWCV 5	BO 1	95 MnWCr 5 KU	SKS 3	2140	T31501
	90 MnCrV 8	1.2842	1.2842	90 MnCrV 8	90 MV 8	BO 2	90 MnVCr 8 KU			T31502
	100 Cr 6	1.3505	1.3505	100 Cr 6	100 C 6	534 A 99	100 Cr 6	SUJ 2	2258	G51986
H8	X 40 CrMoV 5 1	1.2344	1.2344	X 40 CrMoV 5 1	Z 40 CDV 5	BH 13	X 40 CrMo 5 1 1 KU	SKD 61	2242	T20813
	X 100 CrMoV 5	1.2363	1.2363	X 100 CrMoV 5 1	Z 100 CDV 5	BA 2	X 100 CrMoV 5 1 KU	SKD 12	2260	T30102
	X 155 CrVMo 12 1		1.2379	X 155 CrVMo 12 1	Z 160 CDV 12	BD 2	X 155 CrVMo 12 1 KU	SKD 11		T30402
			1.2436	X 210 CrW 12			X 215 CrW 12 1 KU	SKD 2	2312	
			1.2601	X 165 CrMoV 12			X 165 CrMoW 12 KU		2310	
			1.2713	55 NiCrMoV 6	55 NCDV 7			SKT 4		T61206
HS 6-5-2-5	1.3243	1.3243	S 6-5-2-5	Z 85 WDKCV 06-05-05-04-02		HS 6-5-2-5	SKH 55	2723		
HS 2-10-1-8	1.3247	1.3247	S 2-10-1-8	Z 110 DKCWW 09-08-	BM 42	HS 2-9-1-8	SKH 51		T11342	
HS 18-0-1	1.3355	1.3355	S 18-0-1	Z 80 WCV 18-04-01	BT 1	HS 18-0-1	SKH 2		T12001	
H11	X 20 Cr 13	1.4021	1.4021	X 20 Cr 13	Z 20 C 13	420 S 37	X 20 Cr 13	SUS 420 J 1	2303	S42000
	X 70 CrMo 15	1.4109	1.4109	X 65 CrMo 14	Z 70 D 14			SUS 440 A		S44002
	X 90 CrMoV 18	1.4112	1.4112	X 90 CrMoV 18	Z 2 CND 18 05	409 S 19	X CrTi 12	SUS 440 B	2327	S44003
	X 105 CrMo 17	1.4125	1.4125	X 105 CrMo 17	Z 100 CD 17		X 105 CrMo 17	SUS 440 C		S44004
H12	X 4 CrNiCuNb 16 4	1.4540	1.4540	X 4 CrNiCuNb 16 4						S15500
	X 5 CrNiCuNb 16 4	1.4542	1.4542	X 5 CrNiCuNb 16 4				SUS 630		S17400
	X 5 CrNiCuNb 16 4	1.4542	1.4542	X 5 CrNiCuNb 16 4				SUS 630		S17400
	X 7 CrNiAl 17 7	1.4568	1.4568	X 7 CrNiAl 17 7	Z 9 CAN 17.7	301 S 81	X 7 CrNiAl 17 7	SUS 631	2388	S17700
	X 8 CrNiMoAl 15 7 5	1.4574	1.4574	X 8 CrNiMoAl 15 7 5						S15700
	X 6 NiCrTiMoV 25 15	1.4980	1.4943	X 4 NiCrTi 25 15	Z 6 NCTDV 25 15	HR 51		SUH 660	2570	S66286
	X 2 NiCoMo 18 8 5	1.6359	1.6359	X 2 NiCoMo 18 8 5		S 162				K92890
	X 2 NiCoMoTi 18 9 5	1.6358	1.6358	X 2 NiCoMoTi 18 9 5	Z 2 NKD 19-09					K93120
X 2 NiCoMoTi 18 9 5	1.6358	1.6358	X 2 NiCoMoTi 18 9 5	Z 2 NKD 19-09					K93120	
X 2 NiCoMoTi 18 12 4	1.6356	1.6356	X 2 NiCoMoTi 18 12 4						K93160	
H21	X 120 Mn 12	1.3401	1.3401	X 120 Mn 12	Z 120 M 12	BW 10		SC MnH 1	2183	
H31	EN-GJN-HV520	0.9620	0.9620	G-X330 NiCr 4 2	FB Ni4 Cr2 BC	Grade 2 A			05 12-00	F45001
	EN-GJN-HV550	0.9625	0.9625	G-X260 NiCr 4 2	FB Ni4 Cr2 HC	Grade 2 B			05 13-00	F45000
	EN-GJN-HV600(XCr11)	0.9630	0.9630	G-X300 CrNiSi 9 5 2	FB Cr9 Ni5	Grade 2 C, D, E			04 57-00	F45003

SMG

U.N.E./ I.H.A.	AISI / ASTM	GOST	ČSN	Misc. Brands	Condition	Structure
				Discalloy	Precipitation hardened	
				Haynes 25		
				Stellite 21		
				Hastelloy C		
		KHN65MV		Hastelloy C-276		
				IN 100		
				Inconel 718		
				Inconel X-750	Solution annealed	
				Nimonic 80A		
				René 41		
				Udimet 500		
				Waspalloy		
				Ti	Commercially pure	Ti (α)
	AMS 4919			Ti 6-2-4-2	Annealed	Ti (α)
	AMS 4943			Ti 3Al-2.5V (grd 9)	Annealed	Ti ($\alpha+\beta$)
	AMS 4920, Grade 5	VT6		Ti 6Al-4V	Annealed	Ti ($\alpha+\beta$)
	AMS 4986			Ti 10V-2Fe-3Al	Annealed	Ti (β)
F.1516	5115	12KHN2	14 220		Case hardened	
F.5103	1070	70			Quenched & Tempered	
F.5107	1078, 1080	75			Quenched & Tempered	
F.5117	1095				Quenched & Tempered	
F.5118	W1	U10A			Quenched & Tempered	
	S1	5KHV2SF			Quenched & Tempered	
	5155				Quenched & Tempered	
F.1252	4142, 4140	38HM	15 142		Quenched & Tempered	
F.520L	L2	11KHF			Quenched & Tempered	
F.5220	O1	9KHVG			Quenched & Tempered	
	O2	9G2F			Quenched & Tempered	
F.5230	52100	SHKH15	14 109		Quenched & Tempered	
F.5318	H13	4KH5MF1S			Quenched & Tempered	
F.5227	A2	9KH5VF			Quenched & Tempered	
F.5211	D2	KH12MF			Quenched & Tempered	
F.5213		KH12			Quenched & Tempered	
		KH12MF			Quenched & Tempered	
F.520.S	L6	5KHNM			Quenched & Tempered	
F.5613	M35	R6M5K5			Quenched & Tempered	
	M42	R2AM9K5			Quenched & Tempered	
	T1	R18			Quenched & Tempered	
F.5261	420	20KH13	17 022		Quenched & Tempered	Martensitic
	440 A				Quenched & Tempered	Martensitic
	440 B	95KH18			Quenched & Tempered	Martensitic
	440 C	95KH18			Quenched & Tempered	Martensitic
	XM-12			15-5 PH	H900	Martensitic
	SAE 630			17-4 PH	H1025	Martensitic
	SAE 630			17-4 PH	H900	Martensitic
	AMS 5528	09KH17N7YU1		17-7 PH	TH1050	Martensitic
	632			PH 15-7 Mo	TH1050	Martensitic
	660			A286	Precipitation hardened	Austenitic
	AMS 6512			Marage 250	Precipitation hardened	Martensitic
	AMS 6521			Marage 300	Precipitation hardened	Martensitic
	AMS 6521			Marage 300	Precipitation hardened	Martensitic
	AMS 6515			Marage 350	Precipitation hardened	Martensitic
	A128 Grade A			Hadfield		
	A532 IB (NiCr-LC)			Ni-Hard 2		White cast iron
	A532 IA (NiCr-HC)			Ni-Hard 1		White cast iron
	A532 ID (Ni-HiCr)			Ni-Hard 4		White cast iron

Cemented carbide inserts and insert carriers

Cemented carbide inserts and cemented carbide insert carriers from Seco Tools are not included in the product range intended for the following requirements. Nevertheless Seco Tools can make the following declaration.

These products meet all requirements in RoHS (Restriction of the use of certain Hazardous Substances in electrical and electronic equipment), WEEE (Waste Electrical & Electronic Equipment) and ELV (End of Life Vehicles) requirements.

Products do not contain mercury, lead, hexavalent chromium, cadmium, CFC, HCFC, flame retardants or solvents in concentrations that exceed specifications in the regulations.

Regrinding:

Wet or dry grinding can produce potentially hazardous dusts or mists that can irritate skin, eyes, nose, throat and result in lung damage or disease. To avoid injury use proper safety precautions and protective equipment.

Disposal:

Seco Tools will buy back used inserts and solid carbide tools for recycling. Inserts and solid carbide tools should be separated from other metal waste (steel, aluminium, copper etc).

All packing material is fully recyclable.

CBN and PCD inserts

Inserts from Seco Tools are not included in the product range intended for the following requirements. Nevertheless Seco Tools can make the following declaration.

This product meets all requirements in RoHS (Restriction of the use of certain Hazardous Substances in electrical and electronic equipment), WEEE (Waste Electrical & Electronic Equipment) and ELV (End of Life Vehicles) requirements.

Products do not contain mercury, lead, hexavalent chromium, cadmium, CFC, HCFC, flame retardants or solvents in concentrations that exceed specifications in the regulations.

Regrinding:

Wet or dry grinding can produce potentially hazardous dusts or mists that can irritate skin, eyes, nose, throat and result in lung damage or disease. To avoid injury use proper safety precautions and protective equipment.

Disposal:

Seco Tools will buy back used CBN- or PCD-tipped inserts for recycling. Inserts should be separated from other metal waste (steel, aluminium, copper etc). Solid CBN-inserts may be discarded as landfill waste.

All packing material is fully recyclable.

Black oxide insert carriers

Insert carriers from Seco Tools are not included in the product range intended for the following requirements. Nevertheless Seco Tools can make the following declaration.

This product meets all requirements in RoHS (Restriction of the use of certain Hazardous Substances in electrical and electronic equipment), WEEE (Waste Electrical & Electronic Equipment) and ELV (End of Life Vehicles) requirements.

Products do not contain mercury, lead, hexavalent chromium, cadmium, CFC, HCFC, flame retardants or solvents in concentrations that exceed specifications in the regulations.

Disposal:

Used insert carriers may be sent for recycling together with ordinary steel waste (swarf and discarded steel scrap) for recycling.

All packing material is fully recyclable.

Cermet inserts

Inserts from Seco Tools are not included in the product range intended for the following requirements. Nevertheless Seco Tools can make the following declaration.

This product meets all requirements in RoHS (Restriction of the use of certain Hazardous Substances in electrical and electronic equipment), WEEE (Waste Electrical & Electronic Equipment) and ELV (End of Life Vehicles) requirements.

Cermet grade C15M inserts do contain nickel and will leach nickel when in contact with the skin. Amount of leaching is higher than specified in norm SS-EN 1811 Reference test method for release of nickel from products intended to come into direct and prolonged contact with the skin. These norms are intended for products that are in direct and prolonged contact with the skin and are therefore not directly applicable for cermet inserts. Persons with known allergic reactions to nickel are advised to wear protective gloves when handling cermet inserts.

Regrinding:

Wet or dry grinding can produce potentially hazardous dusts or mists that can irritate skin, eyes, nose, throat and result in lung damage or disease. To avoid injury use proper safety precautions and protective equipment.

Disposal:

Used inserts may be recycled. Inserts should be separated from other metal waste (steel, aluminium, copper, etc) including cemented carbide inserts.

All packing material is fully recyclable.

Nickel coated insert carriers

Insert carriers from Seco Tools are not included in the product range intended for the following requirements. Nevertheless Seco Tools can make the following declaration.

This product meets all requirements in RoHS (Restriction of the use of certain Hazardous Substances in electrical and electronic equipment), WEEE (Waste Electrical & Electronic Equipment) and ELV (End of Life Vehicles) requirements.

Products do not contain mercury, lead, hexavalent chromium, cadmium, CFC, HCFC, flame retardants or solvents in concentrations that exceed specifications in the regulations.

Insert carriers do contain nickel and will leach nickel when in contact with the skin. Amount of leaching is not higher than norm SS-EN 1811 Reference test method for release of nickel from products intended to come into direct and prolonged contact with the skin.

These norms are intended for products that are in direct and prolonged contact with the skin and are therefore not directly applicable for insert carriers. Persons with known allergic reactions to nickel are advised to wear protective gloves when handling nickel coated insert carriers.

Disposal:

Used tools maybe sent for recycling together with ordinary steel waste (swarf and discarded steel scrap) for recycling.

All packing material is fully recyclable.

Intentionally added alloying elements

Grade	Cemented carbide											Coating							
	W	Ti	Ta	Nb	Co	Cr	Ni	Mo	C	N	Ru	Ti	Al	C	N	O	Si	Nb	
CP20	■				■				■			■			■				
CP200	■				■	■			■			■	■		■				
CP300	■	■	■	■	■				■			■	■		■				
CP500	■				■	■			■			■	■		■				
CP600	■				■	■			■			■	■		■				
C15M	■	■	■	■	■		■	■	■		■								
CF	■		■		■		■	■	■										
CM	■		■		■		■	■	■										
DP2000	■			■	■				■			■	■	■	■	■			
DP3000	■	■	■	■	■				■		■	■	■	■	■	■			
DS2050	■				■	■			■			■	■		■				■
DS4050	■				■	■			■			■	■		■				■
F15M	■				■	■			■			■	■		■				
F25M	■	■	■	■	■				■			■	■		■				
F30M	■				■	■			■			■	■		■				
F40M	■				■	■			■			■	■		■				
HX	■		■		■				■										
H02	■		■		■	■			■										
H15	■				■	■			■										
H25	■				■	■			■										
KX	■				■	■			■										
MH1000	■				■	■			■			■	■		■				
MK1500	■		■		■				■			■	■	■	■	■			
MK2050	■		■		■	■			■			■	■		■			■	
MM4500	■				■	■			■			■	■	■	■	■			
MP1020	■	■	■	■	■				■			■	■		■				
MP1500	■		■	■	■				■			■	■	■	■	■			
MP2050	■				■				■		■	■	■		■			■	
MP2500	■		■	■	■				■			■	■	■	■	■			
MP3000	■				■	■			■			■	■		■				
MS2500	■		■	■	■				■			■	■	■	■	■			
MS2050	■				■	■			■			■	■		■				■
RX1500	■		■		■		■	■	■			■	■		■				
RX2000	■		■		■	■			■			■	■		■				
RM2020	■				■				■			■							
RM2090	■				■	■			■			■	■					■	
RN2010	■				■	■			■									■	
RS2090	■				■	■			■			■	■					■	
T350M	■		■	■	■				■			■	■	■	■	■			
T25M	■		■	■	■				■			■	■	■	■				
TGH1050	■				■	■			■			■	■		■			■	
TGK1500	■		■		■				■			■	■	■	■	■			
TGP25	■	■	■	■	■				■			■	■	■	■	■			
TGP35	■		■	■	■				■			■	■	■	■	■			
TGP45	■		■	■	■				■			■	■	■	■	■			
TH1000	■				■	■			■			■	■		■			■	
TH1500	■				■	■			■			■	■	■	■	■			
TK0501	■				■	■			■			■	■	■	■	■			
TK1501	■				■	■			■			■	■	■	■	■			
TM2000	■	■	■	■	■				■		■	■	■	■	■	■			
TM4000	■	■	■	■	■				■		■	■	■	■	■	■			
TP0501	■	■	■	■	■	■			■			■	■	■	■	■			
TP1020	■	■	■	■	■				■		■	■	■		■				
TP1030	■	■	■	■	■				■			■	■		■			■	
TP1500	■	■	■	■	■				■			■	■	■	■	■			
TP1501	■	■	■	■	■				■		■	■	■	■	■	■			
TP200	■	■	■	■	■				■			■	■	■	■	■			
TP2500	■	■	■	■	■				■			■	■	■	■	■			
TP2501	■	■	■	■	■	■			■			■	■	■	■	■			
TP3501	■	■	■	■	■				■		■	■	■	■	■	■			
TP40	■		■	■	■				■			■	■	■	■				
TS2000	■				■	■			■			■	■		■				
TS2050	■				■	■			■			■	■		■				
TS2500	■		■		■				■			■	■		■			■	
T250D	■				■	■			■			■	■		■				
T400D	■				■	■			■			■	■		■				
T100R	■		■		■	■			■			■	■		■				
T60M	■	■	■	■	■				■			■	■		■				
883	■		■		■				■										
890	■				■	■			■										

This work is published with the understanding that Seco Tools and its editors are supplying information aimed to present a general orientation and direction of metal cutting and related sciences. If professional services are required for specific applications, the assistance of an appropriate professional should be acquired.

The information is provided “as is”;

Seco Tools and its editors disclaim all representations and warranties, express or implied, of any kind, including, without limitations, any warranties of merchantability, fitness for a particular purpose, title, or non-infringement. In no event will Seco Tools or its editors be liable to any party for any direct, indirect, special or other consequential damages for any use of the information, even if Seco Tools or its editors are advised of the possibility of such damage.

The information provided herein is for reference purposes only. Actual prices, specifications, and product descriptions are finalised at the time of sale and may vary by location.

The information provided herein is subject to change without prior notice.

WWW.SECOTOOLS.COM

03198998, ST20176649 GB,
© SECO TOOLS AB, 2018. All rights reserved.
Technical specifications are subject to
change without notice.